

December 2012

# Application Potential of Solar PV, Wind and Fuel Cells Technologies for Global Sustainability Improvement

Qiang Zhai

*University of Wisconsin-Milwaukee*

Follow this and additional works at: <https://dc.uwm.edu/etd>



Part of the [Mechanical Engineering Commons](#)

---

## Recommended Citation

Zhai, Qiang, "Application Potential of Solar PV, Wind and Fuel Cells Technologies for Global Sustainability Improvement" (2012). *Theses and Dissertations*. 68.  
<https://dc.uwm.edu/etd/68>

This Dissertation is brought to you for free and open access by UWM Digital Commons. It has been accepted for inclusion in Theses and Dissertations by an authorized administrator of UWM Digital Commons. For more information, please contact [open-access@uwm.edu](mailto:open-access@uwm.edu).

APPLICATION POTENTIAL OF SOLAR PV, WIND AND  
FUEL CELLS TECHNOLOGIES FOR GLOBAL  
SUSTAINABILITY IMPROVEMENT

by

Qiang Zhai

A Dissertation Submitted in  
Partial Fulfillment of the  
Requirements for the Degree of

Doctor of Philosophy  
in Engineering

at

The University of Wisconsin- Milwaukee

December 2012

ABSTRACT  
APPLICATION POTENTIAL OF SOLAR PV, WIND AND FUEL  
CELLS TECHNOLOGIES FOR GLOBAL SUSTAINABILITY  
IMPROVEMENT

by

Qiang Zhai

The University of Wisconsin-Milwaukee, 2012  
Under the Supervision of Professor Chris Yingchun Yuan

This dissertation develops a systematic approach to comprehensively investigate the application potential of Solar PV, wind and fuel cells in reducing GHGs emissions for energy intensive global manufacturing industry. This systematic approach is developed by integrating the technological and economic characteristics of the clean energy technologies, as well as the local geographic conditions where the clean energy technologies may be deployed. This approach consists of the investigation on such aspects as: technological feasibility, capacity factor, FIT strength, Levelized energy cost, cost benefit and sensitivity.

In this dissertation, the systematic approach developed is applied on the application potential analyses of solar PV, wind and fuel cells technologies in reducing GHGs for the global automotive manufacturers, at six global locations including Detroit, Mexico City, Sao Paulo, Shanghai, Cairo and Bochum. For the application potential of these three clean energy technologies in reducing GHGs emissions, the technological

feasibility, capacity factor, Levelized energy cost, cost benefit and sensitivity analysis are conducted with different geographic and economic parameters. The cost benefit trends of solar PV, wind and fuel cells in reducing GHGs emissions from 2010-2035 are projected by using this developed approach, with the assumptions of two virtual cost cases. This approach is applied on the cost benefit range analysis in six selected countries to investigate the uncertainty of the GHGs reduction cost benefit due to the geographic difference. Potential cost benefit maps on GHGs emission reduction in the nationwide of the US lower 48 states are generated by using this systematic approach. The sensitivity analysis is applied for the solar PV and wind energies to investigate the linear relevance of different geographic and economic parameters with the cost benefit performance. In the FIT strength analysis of the case study, different geographic locations are selected due to the lack of data.

This dissertation concludes with discussions on the application potential of three clean energy technologies at different global locations in reducing GHGs emission for global manufacturing industry. As there is lack of information support on the selection of appropriate clean energy technologies at specific locations to achieve GHGs emission reduction, this approach developed provides a comprehensive support for decision making.

# TABLE OF CONTENTS

<b>ABSTRACT .....</b>	<b>ii</b>
<b>LIST OF FIGURES.....</b>	<b>vii</b>
<b>LIST OF TABLES.....</b>	<b>ix</b>
<b>ACKNOWLEDGEMENT.....</b>	<b>x</b>
<b>CHAPTER 1 INTRODUCTION AND RESEARCH OBJECTIVES.....</b>	<b>1</b>
1.1 Significance of global warming issue.....	1
1.1.1 GHGs, global warming, and global warming potential (GWP).....	2
1.1.2 GHGs Sources.....	5
1.2 GHGs emission reduction mitigation options.....	7
1.3 GHGs emission reduction options for automotive manufactures.....	8
1.4 Objectives of this research.....	13
<b>CHAPTER 2 TECHNICAL PRINCIPLES AND ENVIRONMENTAL INVESTIGATION OF CLEAN ENERGY TECHNOLOGIES .....</b>	<b>15</b>
2.1 Principles and system configuration of clean energy technologies.....	15
2.1.1 Principle of Solar PV.....	16
2.1.2 Principle of Wind Energy.....	17
2.1.3 Principle of Fuel Cells.....	20
2.2. Life cycle GHG emission analysis of clean energy power systems.....	22
2.2.1 LCA of Solar PV.....	24
2.2.2 Wind energy system.....	26
2.2.3 Fuel cell systems.....	27

<b>CHAPTER 3</b>	<b>A SYSTEMATIC ECONOMICAL ANALYSIS APPROACH</b>	<b>29</b>
3.1	Introduction	29
3.2	Technological Feasibility	34
3.3	Capacity factor	35
3.3.1	Solar PV	37
3.3.2	Wind	38
3.4	Strength Analysis of International Feed-in Tariff Promotion of Clean Energy Applications for Greenhouse Gas Emission Mitigation	40
3.5	Levelized Energy Cost analysis of Solar PV, Wind and Fuel Cell	43
3.6	Cost Benefit Analysis	45
3.7	Sensitivity Analysis	49
<b>CHAPTER 4</b>	<b>APPLICATION POTENTIAL ANALYSIS OF SOLAR PV, WIND AND FUEL CELLS FOR GLOBAL AUTOMOTIVE MANUFACTURING INDUSTRY'S SUSTAINABILITY IMPROVEMENT (A CASE STUDY)</b>	<b>53</b>
4.1	Introduction	53
4.2	Data Collection	59
4.2.1	Meteorological data Collection	59
4.2.2	Economic and environmental data of the representative clean energy technologies	60
4.3	Technological Feasibility Analysis	64
4.4	Capacity Factor	65

4.5 Strength Analysis of International Feed-in Tariff Promotion of Clean Energy Applications for Greenhouse Gas Emission Mitigation.....	69
4.5.1 FIT data by countries.....	72
4.5.2 Comparison of the GHG emissions reduction by Solar PV and Wind.....	74
4.5.3 Calculating the strength of FITs in greenhouse gas emission mitigation.....	77
4.6 Levelized Energy Cost analysis of Solar PV, Wind and Fuel Cell.....	83
4.7 Cost Benefit Analysis.....	85
4.7.1 Cost Benefit Analysis in the Six Selected Global Locations.....	85
4.7.2 Cost Benefit Range in the Six Selected Countries.....	94
4.7.3 Cost Benefit Map for the Down 48 States of U.S.....	96
4.8 Trend Analysis of GHG Emission Reduction Cost Benefit from year 2010-2035.....	100
4.9 Sensitivity Analysis.....	105
<b>CHAPTER 5 Conclusions.....</b>	<b>109</b>
5.1 Main contributions to knowledge.....	109
5.2 Suggestions for practical application.....	112
5.3 Future research directions.....	113
5.3.1 Development of the GHGs emissions related database.....	113
5.3.2 The research and development of cost benefit analysis tools.....	114
<b>REFERENCES.....</b>	<b>115</b>
<b>CURRICULUM VITAE.....</b>	<b>126</b>

## LIST OF FIGURES

Figure 1.1 Trends in Atmospheric CO <sub>2</sub> [NOAA 2011].....	3
Figure 1.2 World CO <sub>2</sub> emissions from fuel combustion in 1973 .....	6
Figure 1.3 World CO <sub>2</sub> emissions from fuel combustion in 2009 .....	6
Figure 1.4 A product life cycle.....	8
Figure 1.5 Annual CO <sub>2</sub> emissions of six major global automakers.....	10
Figure 2.1 Stages of a life cycle assessment.....	24
Figure 2.2 Schematic overview of the life cycle of a PV system.....	25
Figure 2.3 LCA model of a wind turbine.....	27
Figure 2.4 Components of a fuel cell system operated on hydrogen.....	28
Figure 3.1 Structure and scheme of the mathematic model.....	33
Figure 4.1 GM's Total energy usage for U.S. operations 1990-2007.....	55
Figure 4.2 Six selected geographical locations of GM production facilities.....	57
Figure 4.3 Feasibility analyses of clean energy technologies at the six selected global locations.....	64
Figure 4.4 Interpolated Power Curves of Selected Wind Turbines.....	67
Figure 4.5 Capacity factors of solar PV and wind power systems at the six selected locations.....	68
Figure 4.6 GHG emission mitigations through Solar PV and wind by countries.....	76
Figure 4.7 FIT and emission benefit for solar PV.....	78



Figure 4.8 FIT and emission benefit for wind.....	80
Figure 4.9 Levelized Energy Cost for Solar PV, Wind and Fuel Cell.....	84
Figure 4.10 Cost benefit results of GHG mitigation through clean energy supply.....	88
Figure 4.11 Costs of clean energy supply for reducing 5%~30% of GM's GHG emissions.....	91
Figure 4.12 Range of GHG mitigation potential through clean energy supply at the selected six locations.....	93
Figure 4.13 Range of GHG mitigation potential through clean energy supply in the selected six countries.....	95
Figure 4.14 Solar insolation distribution in the US 48 down states.....	97
Figure 4.15 Wind power density contour plots of US 48 down states.....	98
Figure 4.16 GHG emission reduction potential through PV in the US 48 down states.....	99
Figure 4.17 GHG emission reduction potential through wind energy in the US 48 down states.....	99
Figure 4.18 Cost benefit trend of clean energy supply for GHG mitigations from 2010-2035 (reference case).....	103
Figure 4.19 Cost benefit trend of clean energy supply for GHG mitigations from 2010-2035 (decreasing Cost Case).....	104
Figure 4.20 Geographic parameter sensitivity analyses.....	105
Figure 4.21 Technical parameter sensitivity analyses (Detroit).....	106

## LIST OF TABLES

Table 1.1 GWPs of the three common GHGs.....	5
Table 4.1 Meteorological Data of Six Global Locations.....	60
Table 4.2 Selected Solar PV Modules for Power Supply in Automotive Manufacturing.....	61
Table 4.3 Selected wind turbine systems.....	61
Table 4.4 Selected fuel cell stationary power system for electricity generation.....	62
Table 4.5 Economic and environmental data of the representative clean energy technologies.....	63
Table 4.6 GHG emission factors of local grid power supply.....	63
Table 4.7 Comparison of Different FITs by Countries.....	73
Table 4.8 Greenhouse gas emission factors of the seven countries for FIT analysis.....	75
Table 4.9 Calculated wind speed and wind power density.....	87

## ACKNOWLEDGEMENT

First of all, I am deeply grateful to my advisor Professor Chris Yuan, to work with him has been a real pleasure to me, with a lot of inspiration and excitement. He has been a steady influence throughout my Ph.D. career; he has oriented and supported me with promptness and patience. He has always been encouraging me in times of new ideas and difficulties. His high scientific standards and hard work set such a great example to me. I really appreciate his support from my heart.

I would also like to thank Professor Junhong Chen, Professor Ying Li, Professor Zhen He and Professor Vishnuteja (Vishnu) Nanduri for their supports and insightful comments during my preliminary exam, which are helpful to improve the scientific merits of this dissertation.

In addition, I really appreciate the help from all my colleagues in the Laboratory for Sustainable and Nano-Manufacturing (LSNM) at the University of Wisconsin, Milwaukee, especially the help from Huajun Cao, Xiu Lin and Jingwan Huo, who are always willing to help.

Finally, I would like to thank my wife, Nan, for her love and understanding, who has always been there cheering me up, standing by me at good and bad times. I also thank my families for their support and encouragement.

---

## CHAPTER 1 INTRODUCTION

### 1.1 Significance of global warming issue

Global warming issue is mainly caused by the increasing GHGs concentrations in the atmosphere [Wuebbles 2001]. Many changes have been observed caused by global warming, in both natural systems and ecological systems. According to the Intergovernmental Panel on Climate Change (IPCC), based on current emission trends, the average global temperature is expected to rise by 1.4 °C to 5.8 °C between 1990 and 2100 [IPCC 2001]. This could result in severe climate changes including sea level rise and widespread decreases in snow and ice extent, etc., which are extremely of human concern.

Greenhouse gases (GHGs), as the dominant driver of global warming, have increased by an average of 1.6% per year with carbon dioxide (CO<sub>2</sub>) emissions from the use of fossil fuels growing at a rate of 1.9% per year and these trends are expected to continue over the last three decades [IPCC 2007]. Nonetheless, it is projected that global energy demand and associated supply patterns based on fossil fuels, as the main drivers of GHG emissions, will continue to grow [IPCC 2007].

This chapter concentrates on the introduction of GHGs, reduction of GHGs and the role of such clean energies as solar PV, wind and fuel cells should play in this regard.

The following brief introduction of GHGs, global warming, global warming potential, and GHGs reduction aims to fundamentally understand the inherent connections among these phenomena.

### 1.1.1 GHGs, global warming, and global warming potential (GWP)

The increasing of GHGs concentration in the atmosphere is the main driver of global warming. CO<sub>2</sub>, CH<sub>4</sub> and N<sub>2</sub>O are the three most common GHGs in the atmosphere.

The global average concentrations of various greenhouse gases in the atmosphere have reached the highest levels ever recorded, and these concentrations continue to increase.

The combustion of fossil fuels from human activities and land-use changes are largely responsible for the increase. CO<sub>2</sub> levels have increased 31% in the past 200 years [Sims 2004]. The concentration of CO<sub>2</sub>, the most important greenhouse gas, reached a level of 386 ppm by 2009, and further increased to 389 ppm in 2010 [NOAA 2011].

This is an increase of approximately 110 ppm (around +39%) compared to pre-industrial levels. The concentration in 2009 of the six greenhouse gases (GHG) included in the Kyoto Protocol has reached 439 ppm CO<sub>2</sub> equivalent, an increase of 160 ppm (around +58%) compared to pre-industrial levels, as shown in Figure 1.1 [NOAA 2011].

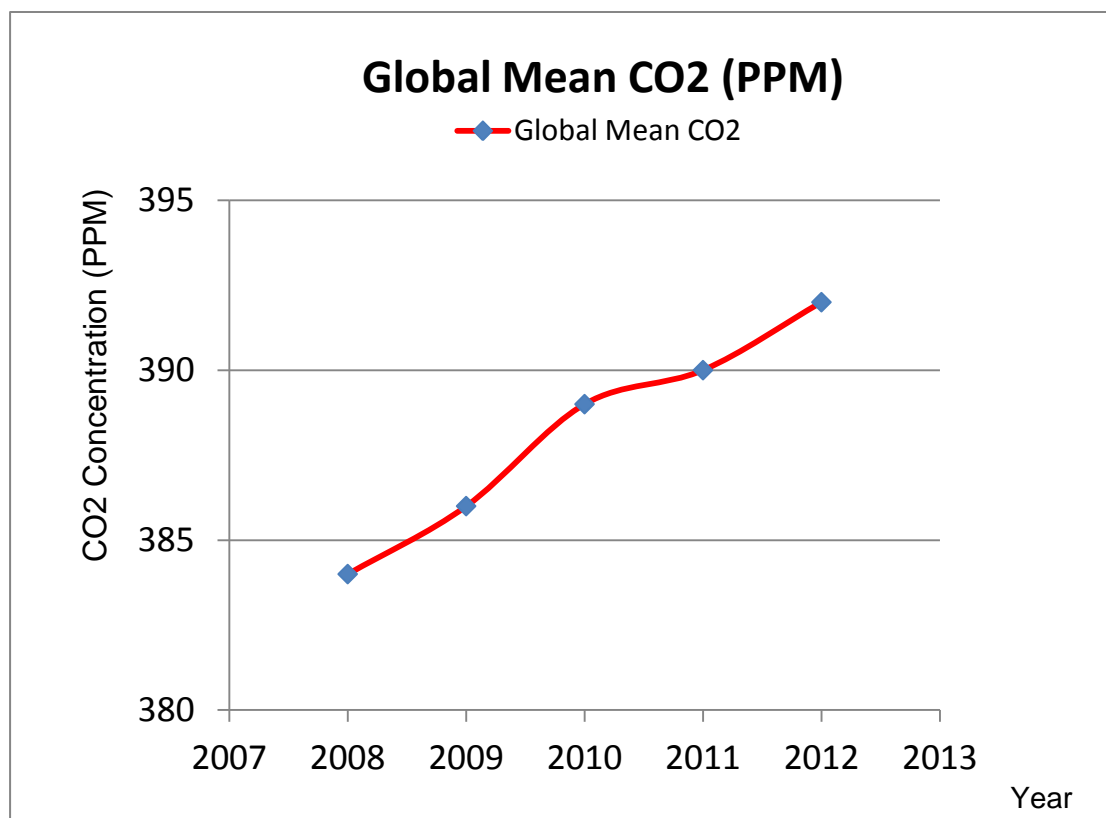

Figure 1.1 Trends in Atmospheric CO<sub>2</sub> [Data source: NOAA 2011]

Besides CO<sub>2</sub>, methane (CH<sub>4</sub>), nitrous oxide (N<sub>2</sub>O), sulphur hexafluoride (SF<sub>6</sub>), and two groups of gases, hydrofluorocarbons (HFCs) and perfluorocarbons (PFCs) are other types of greenhouse gases as regulated in the Kyoto protocol. Different greenhouse gas has different impact on the global warming effect. To compare the radioactive forcing capacity of different gases, an index termed the global warming potential (GWP) is calculated for each gas, as expressed in equation (1-1). For example, methane has a GWP of 23 which means that it is 23 times more effective at trapping heat than CO<sub>2</sub>. GWP is calculated based on the amount of time a gas remains in the atmosphere and its relative effectiveness in absorbing infrared radiation. The

---

IPCC computes greenhouse gas GWPs for 20, 100, and 500 year time horizons [IPCC 1990] [Yuan 2009].

$$GWP_i = \frac{\int_0^{TH} RF_i(t) dt}{\int_0^{TH} RF_r(t) dt} = \frac{\int_0^{TH} \alpha_i \cdot [C_i(t)] dt}{\int_0^{TH} \alpha_r \cdot [C_i(t)] dt} \quad (1-1)$$

Where

*TH*: time horizon

*RF<sub>i</sub>*: the global mean radiative forcing of gas i

*α<sub>i</sub>*: the RF per unit mass increase in atmospheric abundance of gas i (radiative efficiency)

[*C<sub>i</sub>(t)*]: the time-dependent abundance of gas i

In the GWP metric, typical time horizons used for calculations are 20, 100 and 500 years, while the 100 year time horizon is the most commonly used in various analyses and statements. For example, the Kyoto protocol uses the GWP results calculated from a 100 year time horizon. In GWP calculations, the reference gas is commonly selected as CO<sub>2</sub> on which the GWP is set as 1. In equation (1-1), the numerator and denominator are called the absolute global warming potential (AGWP) of gas i and r, respectively [Yuan 2009]. The GWPs of three most common GHGs in the atmosphere are shown in table 1.1 [IPCC 2005] [Forster 2007] [Yuan 2009].

Greenhouse gas	Life Time (years)	Radiative Efficiency ( $\text{Wm}^{-2}\text{ppb}^{-1}$ )	GWP for given time horizon		
			20 yrs	100 yrs	500 yrs
CO <sub>2</sub>	120	1.4x10 <sup>-5</sup>	1	1	1
CH <sub>4</sub>	12	3.7x10 <sup>-4</sup>	72	25	7.6
N <sub>2</sub> O	114	3.03x10 <sup>-3</sup>	289	298	153

Table 1.1 GWPs of the three common GHGs [Yuan 2009, Forster 2007]

### 1.1.2 GHGs Sources

Energy supply is the main GHGs emission source. Taking US as an example, about 87 percent of U.S. greenhouse gas emissions come from energy production and use [GCRP 2008]. Fossil fuels have been sharing the major of the energy mix and will be dominating the mix in a long term. Fossil fuels supplied 80% of world primary energy demand in 2004 [IEA, 2006] and their use is expected to grow in absolute terms over the next 20–30 years in the absence of policies to promote low-carbon emission energy sources. Excluding traditional biomass, the largest constituent were oil (35%), then coal (25%) and gas (21%) [BP 2012]. Global growth in fossil fuel demand has a significant effect on the growth of energy-related CO<sub>2</sub> emissions: both the IEA and the U.S. EIA project growth of more than 55% in their respective forecast periods [IEA 2006].



Figure 1.2 and Figure 1.3 demonstrate the worldwide energy combustion related CO<sub>2</sub> emission from 1973-2009. The fuel combustion related CO<sub>2</sub> emission amount have increased from 15624 Mt in year 1973 to 28999 Mt in year 2009.

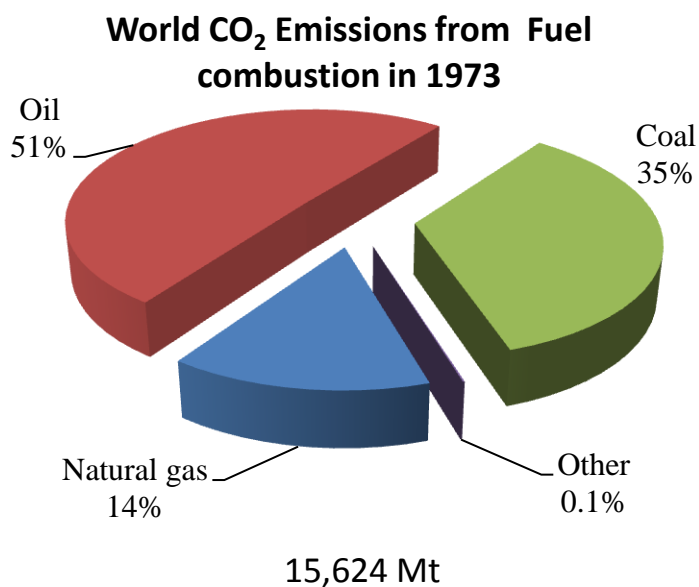

Figure 1.2 World CO<sub>2</sub> emissions from fuel combustion in 1973 [Data Source: IEA 2011]

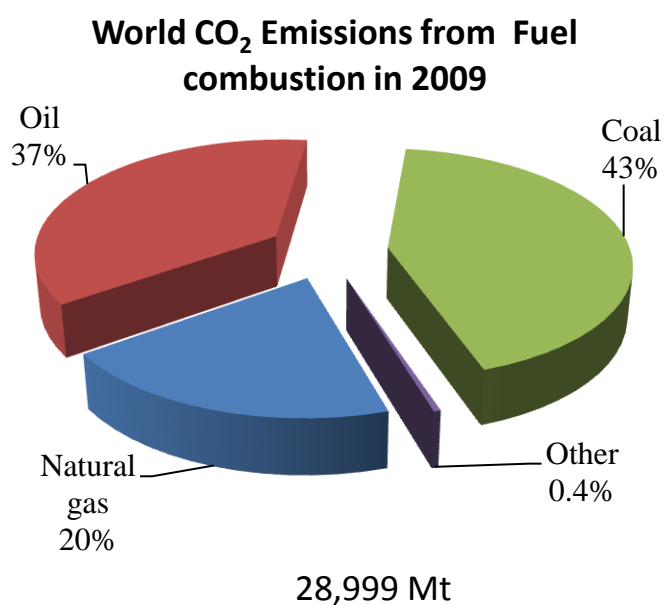

Figure 1.3 World CO<sub>2</sub> emissions from fuel combustion in 2009 [Data Source: IEA 2011]

The discussion in section 1.1 concludes with the following key points:

- a. The global warming effect has been significant.
- b. GHGs emission is the main driver of the global warming effect.
- c. Fossil fuel energy combustion is the main GHGs emission source.

The following discussion focuses on the GHGs emission reduction options and the strategies to achieve this goal.

## **1.2 GHGs emission reduction mitigation options**

There are different GHGs emission reduction options. This research is focused on the global manufacturing industry. In order to find out the possible GHGs emission reduction options for a manufacturing company, the first step is to investigate the GHGs emission sources during the manufacturing process of its products.

A simplified product life cycle is illustrated in Figure 1.4, which includes raw material acquisition, material processing, manufacturing & assembly, use & service, retirement & recovery and treatment disposal. GHGs are produced in each individual part directly and indirectly during these stages. Direct GHGs emission is due to the energy consumption during the production operation. The indirect GHGs emission is due to the purchased electricity.

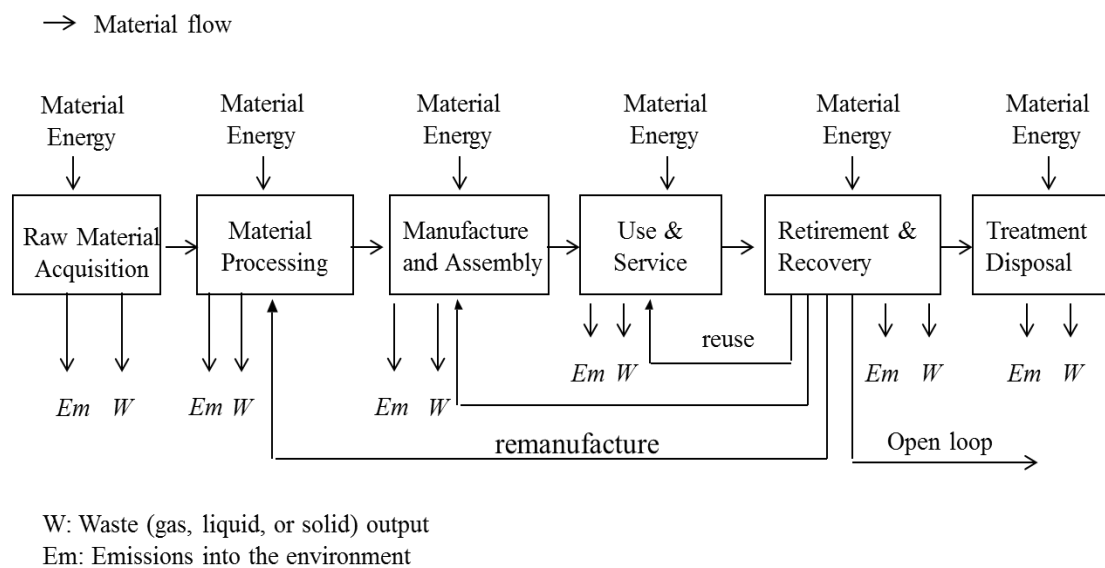

Figure 1.4 A product life cycle

Accordingly, in order for a manufacturing company to reduce its GHGs emission, efforts could be placed on either direct emission reduction or indirect reduction. Direct GHGs emission reduction may be achieved by improving the energy consumption efficiency of each individual production life cycle stage and optimizing the production process. In regard of the indirect GHGs emission reduction, potential reduction could be achieved by using clean energy for supplying the energy demand for production, since these clean energy power systems generate less GHGs emissions than the conventional grid power supply industry.

### 1.3 GHGs emission reduction options for automotive manufacturers

Automotive manufacturing is energy-intensive and requires a significant amount of

---

energy input [Maclean 1998][Yuan 2006][Zhai 2011]. The demanded energy supply is mainly produced from fossil fuel sources, which generate a huge amount of greenhouse gas (GHG) emissions. These GHGs emissions are generated from direct on-site consumption of fossil fuel energy and indirectly from consumption of purchased electricity. As estimated, the manufacture of a typical vehicle requires approximately 120 Giga Joules of energy input [Maclean 1998].

Aware of the significance of global warming resulting from GHG emissions, the global automotive industry has worked intensively to reduce the GHG emissions from their production facilities and manufacturing processes. The Alliance of Automobile Manufacturers (AAM), formed by such major global automotive manufacturers as GM, Ford, Chrysler, Toyota, Mitsubishi, Mercedes, Porsche, Volkswagen, Volvo, and Jaguar, committed to achieve a 10% reduction in greenhouse gas emissions per number of vehicles produced from their U.S. automotive manufacturing facilities by 2012 measured from a base year of 2002 [US DOE 2007]. During the time period between 2002 and 2005, the AAM members has already reduced the GHG emissions intensity of their U.S. facilities, measured as CO<sub>2</sub> emissions per number of vehicles produced, by nearly 3% [US DOE 2007]. As many automotive manufacturers are operating worldwide, the total amount of GHG emissions from their global manufacturing facilities can be very significant. Figure 1.5 below shows the annual GHG emissions from the global manufacturing facilities of the six major automotive manufacturers including GM, Toyota, Ford, Hyundai, Honda and Daimler during

2004-2009.

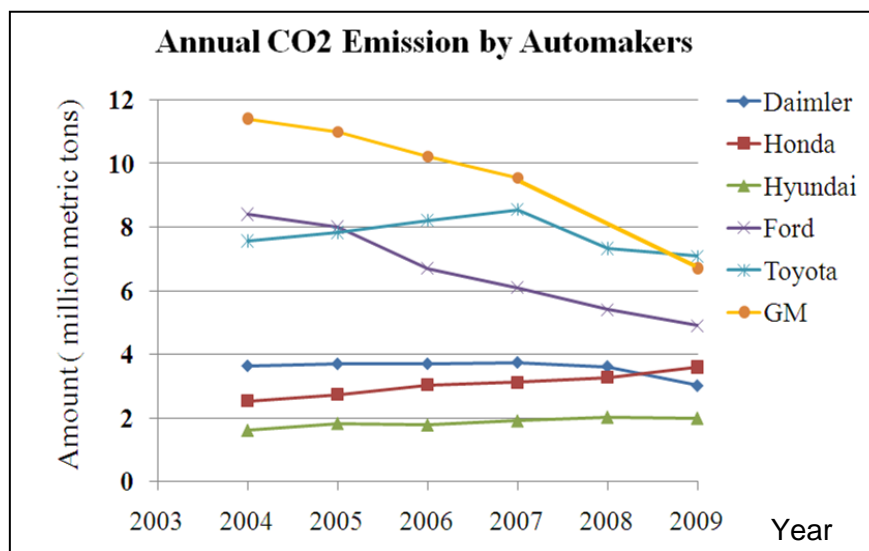

Figure 1.5 Annual CO<sub>2</sub> emissions of six major global automakers [GM 2010][Ford 2007-2010][Daimler 2010][Honda 2008, 2009][Hyundai 2009, 2010][Toyota 2008-2010]

Figure 1.5 demonstrates that the U.S. automotive manufacturers including GM and Ford have reduced their CO<sub>2</sub> emissions significantly in the time period from 2004-2009. The total CO<sub>2</sub> emissions of GM global manufacturing facilities were decreased by 42.11% during the five years time period, from 11.4 million metric tons in 2004 to 6.6 million metric tons in 2009 [GM 2010]; the CO<sub>2</sub> emissions from Ford's global facilities were also reduced by 41.67%, from 8.4 million metric tons in 2004 to 4.9 million metric tons in 2009 [Ford 2007-2010].

The CO<sub>2</sub> emission reductions of GM and Ford facilities are not only from the

down-sizing of their manufacturing scale but also from their intensive efforts on energy efficiency improvements and management on their manufacturing facilities. For instance, GM's U.S. facilities have participated in a total of 1753 projects from 1991-2007 for energy efficiency improvements and conversions of energy sources to lower GHG emitting fuels such as switching from coal to natural gas for the operation of boilers, which has led to a total reduction of GHG emissions over 17 million metric tons CO<sub>2</sub> equivalent [GM 2008]. Through such efforts, the amount of CO<sub>2</sub> emissions per vehicle built from the GM's manufacturing facilities in the U.S. has been decreased from 2.71 metric tons/vehicle in 1990 to 2.2 metric tons/vehicle in 2007 [GM 2008].

However, after decades of continuous improvement, it is difficult to further reduce CO<sub>2</sub> emissions of automotive manufacturing through energy efficiency improvement and management, because automotive manufacturing processes are energy-driven and the grid power supply is mainly produced from fossil fuels.

Thus, a potential solution to this dilemma is to use clean energy technologies such as solar photovoltaic, wind, fuel cells, etc., to partially supply the power needs of automotive manufacturing, so as to further reduce the GHG and associated environmental emissions from automotive manufacturing facilities.

Clean energy technologies are recognized for their cleanliness during power

---

generations and are promoted to use worldwide. Although using clean energy technologies may reduce the GHG emissions, there are still some uncertainties and concerns for their actual implementations in practical production systems. Particularly in the early stage of strategy planning, there are decision-making challenges related to the selection and deployment of a clean energy technology from a number of candidates by global manufacturers such as GM which has manufacturing facilities all over the world. In actual applications, a sound decision is usually required to reduce a maximum amount of GHG emissions with a fixed budget, or reduce certain amount of GHGs with minimum amount of economic cost. However, currently there is a lack of information and data support for decision-making in selecting clean energy technologies and maximizing the cost benefits of clean energy supply for GHG mitigation of large scale industrial manufacturing systems in a global scale.

There are quite a few clean energy technologies for power generation available on the commercial market. Considering the specificity and requirements of automotive production facilities as well as the maturity and adaptability of the various clean energy technologies, three such clean energy power systems, namely solar PV, wind and fuel cells have good potential in stationary power supply and GHG emission reduction for automotive manufacturing industry [Yuan 2009]. In this study, a number of representative power systems based on these three clean energy technologies have been selected to assess their potential application in GHG mitigation at automotive manufacturing facilities located at different global geographical locations.

#### **1.4 Objectives of this research**

The objective of this dissertation research is to comprehensively investigate the application potential of such clean energy technologies as solar PV, wind and fuel cells, in GHGs reduction, for global automotive manufactures, as well as similar large scale global manufacturing industry. The specific objectives are as follows:

- 1). To develop a mathematical model to quantify the cost benefit of clean energy supply for GHGs emission reduction, as a general decision tool to support decision-making in assessing the application potential of various clean energy technologies for power supply of large-scale manufacturing facility.
  
- 2). To investigate the dependence of the clean energy technologies' performance in GHGs reduction, on geographical conditions and technological characteristics. For example, the dependence of solar PV on the local solar insolation, local grid power GHG emission level and the GHG emission level of the selected PV module will be quantitatively discussed.
  
- 3). To conduct a case study on three popular clean energy technologies including solar PV, wind and fuel cells stationary power supply systems. The case study will be conducted at six global locations as the representatives of different worldwide regions



including Detroit (United States), Mexico City (Mexico), Sao Paulo (Brazil), Shanghai (China), Cairo (Egypt) and Bochum (Germany).

4). To investigate the linear relevance of different technological and geographical parameters and the cost benefits. A relative priority on what parameter should be considered in the early stages of decision-making is important for decision makers. This linear relevance will be illustrated by a sensitivity analysis using Pearson's correlation coefficient analysis method.

---

## **CHAPTER 2 ENVIRONMENTAL SAVING OF GREEN HOUSE GAS EMISSIONS FROM LOCAL POWER SUPPLY SYSTEMS BY USING CLEAN ENERGY TECHNOLOGIES**

For all clean energy chains, inputs of energy resources and emissions of GHGs are extremely low compared with conventional systems [Pehnt 2006]. Solar PV, wind and fuel cells are considered as clean energies because these power systems produce fewer GHG emissions than the conventional grid power supply industry. However, such clean energy technologies are not completely clean. Certain amounts of emissions are still produced in various phases of their life cycle, including raw material acquisition, manufacturing, end-of-life, etc. When it comes to using such clean energy technologies to replace the conventional grid power supply for the global manufacturing industry, the lifecycle GHG emissions of such clean energy technologies must be considered in the assessment of the overall GHG mitigation potential of such applications. In this chapter, the technical principles of the solar PV, wind and fuel cells power systems selected for this study will be briefly introduced. In order to understand the mechanism of GHG emission mitigation by clean energy power supply, the associated life cycle assessment background will also be introduced.

### **2.1 Principles and system configuration of clean energy technologies**

### 2.1.1 Principle of Solar PV

Solar photovoltaic systems use the photoelectric effect of semiconductor materials to convert solar energy (solar photons) directly into electricity. This energy conversion is mainly performed by the major component of PV systems, the solar module, normally a number of cells connected in series. Solar PV power systems produce negligible emissions during their operation and maintenance, but there are still emissions associated with other lifecycle phases of a solar PV power system, including raw material acquisition and production, system manufacturing, and end-of-life.

On the other hand, the electricity generation of solar PV depends on the solar insolation level the PV system is exposed to, which is closely linked to the geographical location where the PV system is deployed. Thus the practical performance of a solar PV power system highly depends on the local seasons and weather. Another drawback of solar PV application is that it needs vast area of land to build the power system.

In general, the actual power output of a Solar PV system in terms of AC electricity supply can be calculated through the following equation:

$$AC_{out} = n_m \times I_{ave} \times A_m \times e_m \times f_{DC-AC} \quad (2-1)$$

Where

$AC_{out}$ : annual power output, AC electricity (kWh/year)

---

$n_m$ : number of PV modules

$I_{ave}$ : average annual solar insolation (kWh/m<sup>2</sup>/year)

$A_m$ : surface area of one PV module (m<sup>2</sup>)

$e_m$ : module efficiency

$f_{DC-AC}$ : DC-AC conversion efficiency

Equation (2-1) demonstrates that, with the same surface area, the annual power output will be decided by the technological parameter, module efficiency and the average annual solar insolation. In this regard, both the technological and geographic characteristics should be considered when the solar PV technology is assessed.

### 2.1.2 Principle of Wind Energy

Wind is another form of solar energy, generated by uneven solar heating of the earth's land and sea surfaces. Wind power output is dependent on the wind energy density of the geographic location where the wind turbine is installed. At a specific location, environmental parameters such as wind speed and air density (related to temperature, atmospheric pressure and altitude) jointly determine the wind energy density.

The wind speeds vary with the heights above the surface of the earth, and the wind speed values obtained from the public reports are typically for 10 or 50 m height

above the ground. Wind speeds at other heights can be obtained by using the following transformation [Simiu 1978][Chang 2003]:

$$v_z = v_0 \left( \frac{z}{z_0} \right)^k \quad (2-2)$$

Where

$v_z$ : wind speed at  $z$  m height above the ground (m/s)

$v_0$ : wind speed at specified height of  $z_0$  (m/s)

$z_0$ : specified height (m)

$k$ : Hellman exponent ( $k = 0.34$ )

In Equation (2-2), the Hellman exponent value is a key parameter. The  $k$  value depends on the location and the shape of the terrain on the ground and the stability of the air [Kaltschmitt 2007]. In urban areas, the  $k = 0.34$  value is usually selected for the condition of neutral air above human inhabited areas [Kaltschmitt 2007]. As a result, the wind power density can be calculated through the following expression [Chang 2003]:

$$W = \frac{P}{A} = \frac{1}{2} \rho \times v_z^3 \times \Gamma\left(\frac{\lambda + 3}{\lambda}\right) \quad (2-3)$$

Where

$W$ : wind power density ( $\text{W}/\text{m}^2$ )

$P$ : air pressure ( $\text{Pa}$  or  $\text{N}/\text{m}^2$ )

$A$ : area ( $\text{m}^2$ )

$\rho$ : air density ( $\text{kg}/\text{m}^3$ )

$v_z$ : wind speed at  $z$  m height ( $\text{m}/\text{s}$ )

$\lambda$ : the dimensionless Weibull shape parameter  $\Gamma(\cdot)$ : the gamma function of  $(\cdot)$ , e.g.  $\Gamma(1)=1$ ,  $\Gamma(1.5)=0.886$ ,  $\Gamma(2)=1$ ,  $\Gamma(2.5)=1.329$ , and  $\Gamma(3)=2$ .

The air density  $\rho$  is related to temperature, atmospheric pressure and altitude, and can be determined by [Chang 2003][Oztopal 2000]:

$$\rho = P / RT (\text{kg} / \text{m}^3) \quad (2-4)$$

Where

$R$ : the specific gas constant ( $287 \text{ J kg}^{-1} \text{ Kelvin}^{-1}$ )

$T$ : air temperature in degrees Kelvin ( $\text{deg. C} + 273$ )

The air density could also be expressed as [Chang 2003][Oztopal 2000]:

$$\rho = (P_0 / RT) \exp(-gz / RT) (\text{kg} / \text{m}^3) \quad (2-5)$$

Where

---

$P_0$ : standard sea level atmospheric pressure (101,325 Pascals)

$g$ : the gravitational constant ( $9.8 \text{ m/s}^2$ ); and  $z$  = the region's elevation above sea level (in meters)

In practice, the power output of a wind turbine is calculated from the power curve, which is a graph that indicates the power output values at different wind speeds. This power curve is normally provided when the wind turbine is installed as the form of either a graph or a set of numeric values.

### 2.1.3 Principle of Fuel Cells

Fuel cells are electrochemical devices. A fuel cell is very much similar to a battery in its mode of electricity generation. The major difference between a fuel cell and a battery is that a fuel cell needs a continuous supply of fuels to produce electricity, while a battery has chemicals stored inside that react and produce electricity.

Fuel cells can be used for large-scale industrial power supply when sufficient amounts of fuels are supplied continuously into the system. Typical fuel cells are developed to use hydrogen (or hydrogen fuels) to produce electricity. Taking hydrogen as an example, the chemical reaction within the fuel cell system can be described as follows:

---

Anode side:



Cathode side:



Net reaction:



When using hydrogen as fuel, a fuel cell power system only produces water emissions during operation, and no GHG emissions. Accordingly, the use of fuel cell power systems can significantly reduce the GHGs emissions compared to conventional power supplies. However, currently there are quite a number of challenges associated with hydrogen fuel production, storage and use in fuel cells. As a result, natural gas is more commonly used in stationary fuel cell power systems. Although the natural gas consumed in a fuel cell power system is only involved in the oxidation process, instead of burning, the carbon elements of natural gas are still converted into CO<sub>2</sub> emissions.

If a natural-gas based fuel cell power system will be used, a quantitative trade-off analysis must be conducted to evaluate the GHG mitigation potential of the fuel cell power system, between the life cycle GHG emissions of a fuel cell power system and



the GHG emissions of the conventional grid power supply, based on the same amount of electricity generation.

Fuel cells have an advantage over solar and wind energy in that fuel cells are not limited by geographic conditions. The power efficiency of the fuel cell power systems can always be maintained at the rated output level and it can provide a steady power supply as long as sufficient fuels are supplied continuously into the system. Currently, fuel cells are mainly developed as mobile energy sources for transportation applications. For stationary power generations, there are only a few models available in the United States. In this analysis, two fuel cell stationary power systems are selected, with one system using hydrogen fuel, and the other one using natural gas.

## **2.2. Life cycle GHG emission analysis of clean energy power systems**

Although clean energy technologies such as solar PV and wind are low carbon or zero carbon during the operation stage, there are GHG emissions during their production stages. In order to comprehensively understand the GHG emission generation mechanism of clean energy power systems, here in this section the life cycle assessment method is introduced.

The GHG emission factor used in the following chapters of clean energy power systems are collected from related LCA studies.

---

Standard Life cycle assessment (LCA) was developed more than half century ago as a tool for analyzing environmental issues. The objective of LCA is to describe and evaluate the overall environmental impacts of a certain action by analyzing all stages of the entire process from raw materials supply, production, and transport and energy generation to recycling and disposal stages -following actual use, in other words, “from the cradle to the grave”. Energy production has obvious health and environmental impacts. The procedures of life cycle assessment (LCA) are part of the ISO 14000 environmental management standards: in ISO 14040:2006 and 14044:2006 [ISO 2006].

A brief introduction is given in the next paragraph to explain the scheme of LCA [ISO 2006]: As a systematic approach, LCA process consists of four stages: goal and scope definition, inventory assessment, impact assessment and interpretation as illustrated in Figure 2.1. Goal and scope definition is the phase of the LCA process that defines the purpose and method for including life cycle environmental impacts in the decision-making process. A life cycle inventory (LCI) assessment is the process of quantifying the energy and raw material requirements as well as various wastes and emissions including atmospheric emissions, waterborne emissions, solid wastes and other releases from the entire life cycle of a product, process or activity. In the life cycle inventory phase of an LCA, all relevant data are collected and organized. The outcome of the inventory assessment is a list containing the quantities of pollutants released to the environment and the amount of energy and materials consumed in the life cycle of the product. The life cycle impact assessment (LCIA) phase of an LCA is the evaluation of potential human health and environmental impacts of the

---

environmental resources and releases identified during the life cycle inventory (LCI). Impact assessment should address ecological effects and human health effects; it may also address resource depletion. Interpretation is a systematic technique to identify, quantify, check and evaluate information from the results of the life cycle inventory (LCI) and the life cycle impact assessment (LCIA) and communicate them effectively. Interpretation is the last phase of the LCA process.

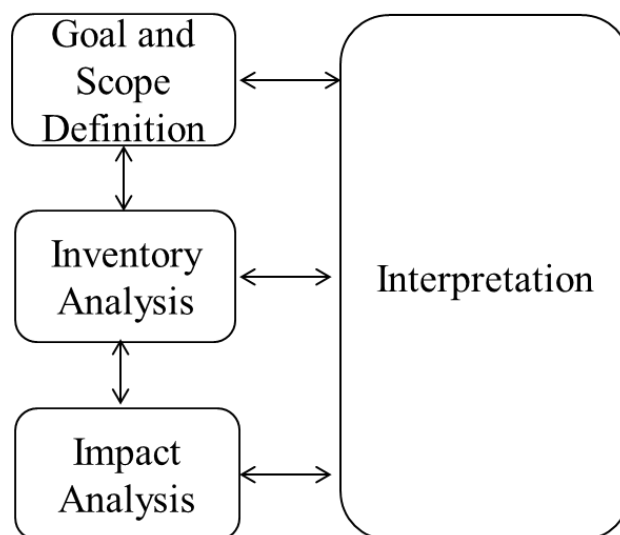

Figure2.1 Stages of a life cycle assessment [Data source: ISO 2006]

### 2.2.1 Solar PV

PV technology converts the sun's rays directly to electrical energy without environmentally harmful discharges. The life cycle of a PV system consists of four main phases: Manufacturing of modules, Production of Balance of System (BOS),

Installation, Operation and Maintenance and End-of-life [ECLIPSE 2004]. Figure 2.2 illustrates simplified process-flow diagrams from mining to system manufacturing stages, namely cradle-to-gate for mono-, ribbon-, and multi-Si PVs.

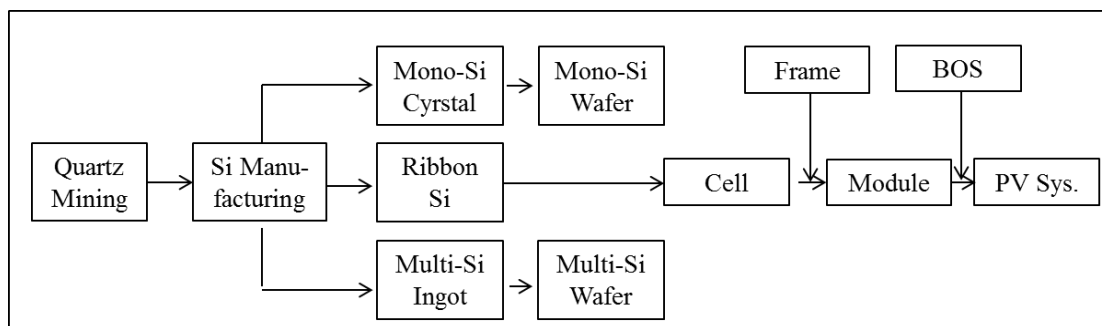

Figure 2.2 Schematic overview of the life cycle of a PV system [Data source: Vasilis 2008]

Previous life-cycle studies reported a wide range of primary energy consumption for PV modules. Meijer et al. evaluated 270- $\mu$ m-thick Si PV with 14.5% cell efficiency fabricated from electronic-grade high-purity silicon [Meijer 2003]. Jungbluth reported the life-cycle metrics of various PV systems (2000 vintage) under average insolation in Switzerland (1100 kWh/m<sup>2</sup>/yr). He estimated greenhouse gas (GHG) emissions in the range of 39–110 g CO<sub>2</sub>-equiv/kWh [Jungbluth 2005] [Vasilis 2008]. There are a few life-cycle studies of thin-film PV technologies; these include those of CdTe PV by Palz and Zibetta, Hynes et al., and Kato et al., and the amorphous silicon studies by Keoleian and Lewis [Palz 1991][Hynes 1994][Keoleian 1997][Fthenakis 2008]. Fthenakis and Alsema reported the 2004-early 2005 status of the EPBTs and of

greenhouse gas (GHG) emissions in four different photovoltaic rooftop installations, namely ribbon- Si, multicrystalline Si (multi- or mc-Si), monocrystalline Si, and thin-film CdTe systems [Fthenakis 2006, 2008].

### 2.2.2 Wind Farm

Although wind power system does not produce pollution or emissions during operation, there is an environmental impact due to the manufacturing process of the wind turbine and the disposal process at the end of the wind turbine life cycle, and this environmental impact should be quantified in order to compare the effects of the production from the point of view of LCA. The life cycle of wind turbine is illustrated as figure 2.3 [Eduardo 2009].

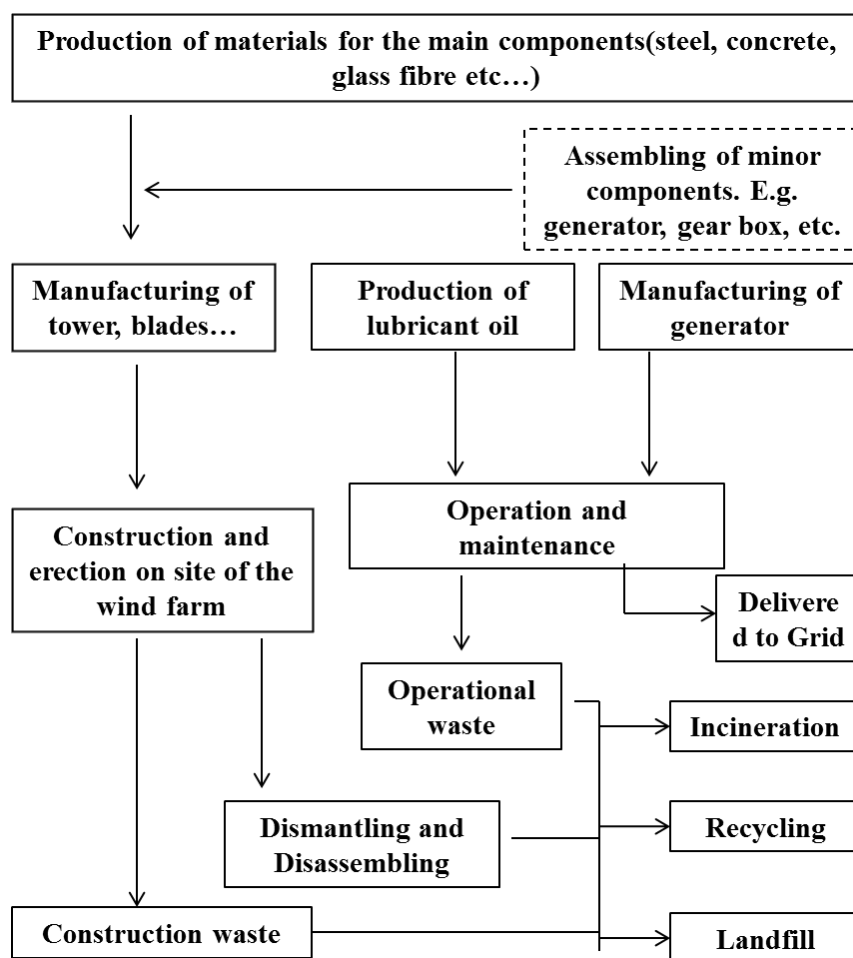

Figure 2.3 LCA model of a wind turbine [Data source: Martínez 2009]

### 2.2.3 Fuel cell systems

Fuel cells are electrochemical devices which convert chemical energy of a reaction directly into electrical energy. They generate DC current by the electrochemical oxidation of fuel (normally hydrogen) and reduction of the oxidant (usually oxygen from the air). As illustrated in figure, the main components of a fuel cell system include fuel processor to clean up the fuel and generate hydrogen, fuel cell which generates DC power, power conditioner to convert DC into AC power and water and heat management units.

In addition to the main components, the fuel cell system also comprises a so called "balance of plant"(BoP) which includes pumps, controls and safety system. The actual specification of components of the BoP will depend on the type of fuel cell.

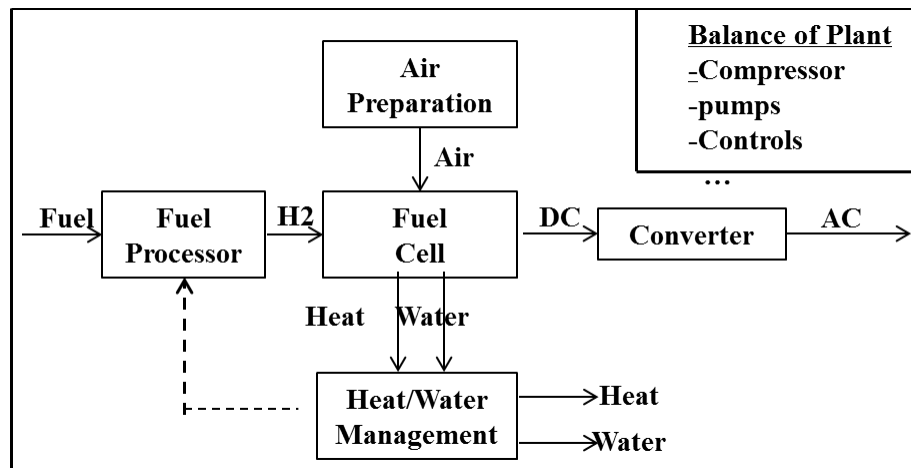

Figure 2.4 Components of a fuel cell system operated on hydrogen [Data source: Azapagic 2002]

---

## **CHAPTER 3 A SYSTEMATIC APPROACH TO INVESTIGATE THE APPLICATION POTENTIAL OF CLEAN ENERGY POWER SYSTEMS FOR GHG EMISSION MITIGATION**

### **3.1 Introduction**

As discussed in the above chapters, clean energy technologies may be potentially a choice for the manufacturing companies to be practically applied to reduce their GHG emissions. However, currently there are quite many different types of clean energy technologies on the global clean energy market, such as solar, wind, geothermal, bioenergy, fuel cells and so forth. Many of these clean energy technologies have been applied with variety of industrial uses as energy supplies. Different types of clean energy technologies have different technological characteristics, economic performances, environmental impacts and other characteristics due to their specific energy producing principles. When it comes to a decision to be made, the selection of one of the optional types of clean technologies is a complicated process. On the one hand, the goal of the manufacturing companies is to achieve the GHG emission reduction through the selected clean energy technology application for their production, apparently many types of clean energy technologies may have the qualification to be considered. On the other hand, the expected cost of the option against the total expected benefits should be optimal for the manufacturing companies. However, currently there is a lack of information and data support for



decision-making in selecting clean energy technologies and maximizing the cost benefits of clean energy supply for GHG mitigation of large scale industrial manufacturing systems in a global scale.

In this chapter, a mathematical model is developed to quantify the cost benefit of clean energy supply, as a general decision tool to support decision-making in assessing the application potential of various clean energy technologies for power supply of large-scale manufacturing facility.

Since the clean energy technologies (such as solar and wind) are dependent on geographical environmental conditions, in this analysis the geographical factors are also integrated in the mathematic model to provide a robust decision support for implementation of clean energy supply during sustainable manufacturing practice. For solar PV technology, the different surface meteorological conditions, such as the average sunshine time and the average solar insolation intensity will have significant impact on the performance of the installed PV panels. For wind energy, local meteorological conditions such as local temperature, altitude, and average wind speed will be the major determining factors for the performance of a wind turbine. In the developed model, the technological characteristics of solar PV and wind energy associated with such above geological factors will be investigated.

---

Although solar and wind are widely adopted in global energy production systems, the economic cost of electricity generated from solar and wind are still higher than that of grid power [Yuan 2009]. As a result, for promotion of the large scale clean energy application in global power generation system, the existence and strength of clean energy incentive laws play an important role in the global deployment of clean energy technologies [Loy 2004] [REN21 2009]. One of the most important incentives adopted worldwide for clean energy power promotion is Feed-in-Tariff (FIT) as implemented in various countries. In this study, the international FITs will be discussed in terms of the comparison of the strength in different global regions. This section of discussion will provide an extensive view for the decision makers to look into the world wide clean energy incentive policy mechanisms. This section of discussion will provide an integrated method to look into the benefits by the FITs on the GHG emission reduction using clean energy technologies as power supplies.

In many cases, there are no available standard or reference to justify whether one specific clean energy technology is practically compatible for the application of GHG emission reduction. This uncertainty is not only decided by the technological principles of the specific technology; it has to do with the specific local geographical conditions, especially for such technologies as solar PV and wind energy. In the developed model, the technological feasibility analysis will provide an approach to investigate the practical compatibility for specific clean energy technologies at specific global geographic locations.

When evaluating the practical application potential of different clean energy technologies with the goal of GHG emission reduction, a quantitative method is needed to compare the cost and benefits. The cost benefit analysis method in this study, as one of the core evaluation criteria, will help investigate the GHG emission reduction benefits with a unit amount of economic investment.

In order for the decision maker to understand the inherent impact of the technological characteristics and the local geographic parameters onto the cost benefit, a sensitivity analysis will be integrated into this model. In the sensitivity analysis, the linear relevance among the technological, economic parameters and the output cost benefits will be investigated qualitatively and quantitatively.

The structure and scheme of the developed model, as well as the relationship of each part of the methodology is illustrated in Figure 3.1. The mechanism of the mathematical model will be discussed in the following sections in details.

A case study is conducted on solar PV, wind and fuel cell stationary power supply systems. In the case study, the clean energy technologies are evaluated for their application potential onto the global manufacturing facilities of GM at six locations where its global facilities are located, including Detroit (United States), Mexico City (Mexico), Sao Paulo (Brazil), Shanghai (China), Cairo (Egypt) and Bochum (Germany). It is expected that this study would be useful for global automotive

manufacturers in decision-making and strategy-setting of employing clean energy technologies to mitigate their GHG and associated environmental emissions.

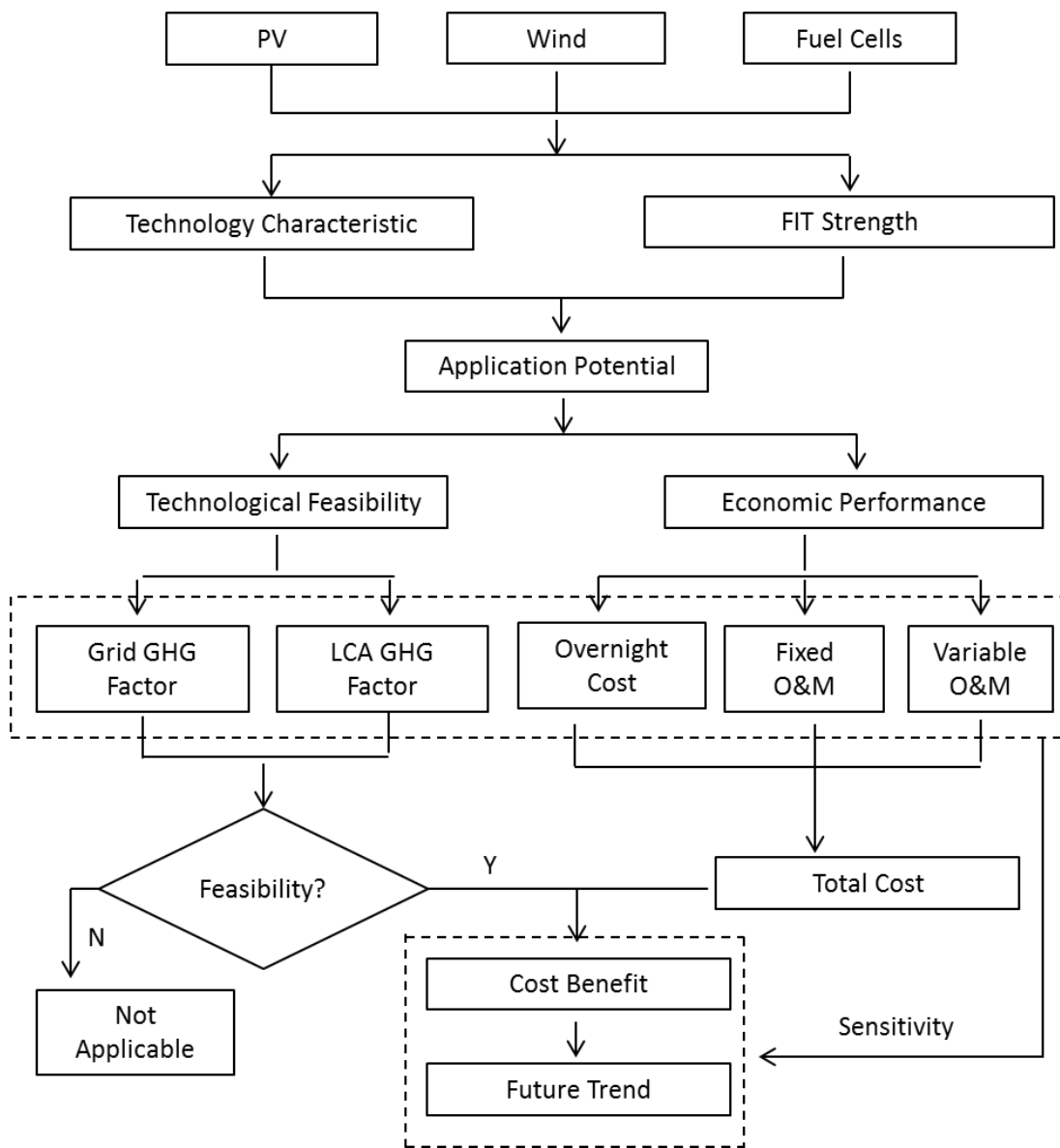

Figure 3.1 Structure and scheme of the mathematic model

---

### 3.2 Technological Feasibility

For assessing the application potential of clean energy supply in GHG emission mitigation of manufacturing facilities, the first step is to identify the feasibility of the clean energy supply at a specific geographic location. Since clean energy technologies such as solar PV, wind, fuel cells, etc., all generate GHG emissions from their life cycle; the amount of GHG emissions from the life cycle of the clean energy power systems will be considered as an important factor. In order for the goal of GHG emission mitigation to be practically achieved, the amounts of GHG emissions from the life cycle of the clean energy system must be lower than those from the grid power supply, based on the same amount of power delivery. Here the GHG emission factors of both grid power supply and clean energy system are employed for the technological feasibility analysis. Such GHG emissions as CO<sub>2</sub>, CH<sub>4</sub>, N<sub>2</sub>O, etc., from both grid power supply and clean energy systems are included in the analysis and all converted to CO<sub>2</sub> equivalent amount using the standard Global Warming Potential (GWP) metric [IPCC 2007].

The emission factor of a local grid power supply is the amount of GHG emissions released into the atmosphere for per kWh electricity supplied, which is determined based on the energy consumption during electricity generation process by the local power grid. Due to the difference of energy sources and their proportions in the local electricity supply mix, the GHG emission factors from grid power supply are quite

different in different locations. Hence the feasibility of a clean energy supply for a specific geographic location can be evaluated using following equation.

$$F^i = \sum_{j=1}^n (GWP^j f_{grid}^j) - \sum_{j=1}^n (GWP^j f_i^j) \quad (3-1)$$

Where

$F^i$ : feasibility of clean energy supply i, kg/kWh; if  $F^i > 0$ , feasible; otherwise, not feasible.

$GWP^j$ : Global Warming Potential of the  $j^{\text{th}}$  GHG,

$f_{grid}^j$ : The  $j^{\text{th}}$  GHG emission factor of a local grid power supply, kg/kwh

$f_i^j$ : The  $j^{\text{th}}$  GHG emission factor from the life cycle of  $i^{\text{th}}$  clean energy power system, kg/kwh

After being investigated through the feasibility analysis, whether one specific clean energy technology has the potential for the GHG emission reduction application will be clarified. The clean energy technologies with the technological feasibilities will be then investigated by the next analysis step.

### 3.3 Capacity Factor

For such clean energy technology application as solar PV and wind energy at a specific location, although the energy density information can serve as the basic

---

indicator of the application potential, further analyses are needed to understand more about the actual implementation scenarios of these clean energy power systems at different geographic locations. For solar and wind energy, here the capacity factor is employed as a meaningful metric to assess their actual application potential at the selected locations.

The capacity factor is defined as the ratio between the actual power output and the total rated power of the system available for the power generations. The expression of capacity factor is shown in Equation (3-2) below:

$$CF = \frac{P_{output}}{P_{system}} \times 100\% \quad (3-2)$$

Where

$CF$ : capacity factor of a power supply system

$P_{output}$ : actual power output of the supply system, kW

$P_{system}$ : rated power of the supply system, kW

Since the power generation mechanisms are quite different for solar and wind energy power systems, the details of the calculation for capacity factors are presented in the following sections.

### 3.3.1 Solar PV

For a Solar PV plant, the capacity factor can be expressed by:

$$CF_s = \frac{E_o}{P * N * t} \quad (3-3)$$

Where

$CF_s$ : Capacity factor of solar PV system

$E_o$ : Life time electricity output, kWh

$P$ : Rated power of one solar PV module, kW

$N$ : Number of solar PV modules

$t$ : Total operation time of solar modules, hour

The life time electricity output can be calculated by:

$$E_o = P_o \times \eta_{DA} \times \sigma_T \times N \times t \quad (3-4)$$

Where

$P_o$ : Actual output power of solar module, kW

$\eta_{DA}$ : DC-AC de-rate factor. In most cases, 0.77 will provide a reasonable estimate

$\sigma_T$ : Temperature effect factor



---

$t$  : Total operation time of solar modules, hour

Most crystalline silicon solar cells decline in efficiency by 0.50%/°C and most amorphous cells decline by 0.15-0.25%/°C.

Alternatively, the electricity lifetime output of Solar PV plants can also be calculated by:

$$E_o = I_s \times \eta_m \times A \times \eta_{DA} \times \sigma_T \times N \times n \quad (3-5)$$

Where

$I_s$  : Annual solar insolation, kWh/m<sup>2</sup>/year

$\eta_m$  : Solar PV module efficiency

$A$  : The surface area of module panel, m<sup>2</sup>

$n$ : Total operation time of solar modules, year

### 3.3.2 Wind

A wind turbine is "fueled" by wind, instead of conventional fossil fuel. Wind blows steadily at some times and not at all at other times. Technically, a modern utility-scale wind turbine operates 65% to 90% of the entire lifetime, but it often runs at less than full capacity. Therefore, the capacity factor for a modern utility-scale wind turbine is less than that, typically, the factor is about of 25% to 40% [AWEA 2010]. The capacity factor of a wind Farm can be calculated by:

$$CF = \frac{P_o}{P_i} \quad (3-6)$$

---

Where

$P_i = D_w \times A_s$ , input power

$D_w$ : Wind power density, kW/m<sup>2</sup>

$A_s$ : Swiping area of turbine blades, m<sup>2</sup>

$P_o$ : Output power under annual average speed according to the power curve of the applied turbine, kW

It is important to realize that while capacity factor is almost entirely a matter of reliability for a fueled power plant, it is not for a wind farm. For a wind farm, it is a matter of economical turbine design. With a very large rotor and a very small generator, a wind turbine would run at full capacity whenever the wind blew, which would generate 60-80% capacity factor, but it would produce very little electricity. The most electricity per dollar of investment is gained by using a larger generator and accepting the fact that the capacity factor will be low as a result. Wind turbines are fundamentally different from fueled power plants in this respect [AWEA 2010].

For a fuel cell system, although the calculation of its capacity factor could be conducted by the similar principle introduced above, it is not necessary for this to be done. In general, for a specific Fuel Cell system, the capacity factor is provided as one of the product specifications.

### **3.4 Strength Analysis of International Feed-in Tariff Promotion of Clean Energy Applications for Greenhouse Gas Emission Mitigation**

Although solar and wind are widely adopted in global energy production systems, the economic cost of electricity generated from solar and wind are still much higher than that of grid power [Yuan 2009]. As a result, for promotion of the large scale clean energy application in global power generation system, the existence and strength of clean energy incentive laws play an important role in the global deployment of clean energy technologies, [Loy 2004] [REN21 2009]. One of the most important incentives adopted worldwide for clean energy power promotion is Feed-in-Tariff (FIT) as implemented in various countries.

The FIT provides a guaranteed price paid per kilowatt-hour (kWh) generated by a clean power installation for a guaranteed number of years [Cory 2009]. The guaranteed price paid and timeframe of a FIT can vary with country and technology, and the prices paid are usually separated into specified amounts for different brackets of eligible installation capacity [Gipe 2010]. The tariffs are paid to the clean power supplier by the utility companies, grid providers, or in some cases, the government.

The FIT is advantageous to manufacturers dedicated to reduce their GHG emissions and therefore, it is important for global businesses to understand the financial and

---

GHG emission mitigation benefits they are provided by various FIT laws for which their plants can be eligible.

Under different situations, Feed-in-Tariff has several meaning. “Feed-in Tariffs” typically refer to the regulatory, minimum guaranteed price per kWh that an electricity utility has to pay to a private, independent producer of renewable power fed into the grid [Monthorst 1999]. But, occasionally, the concept ‘feed-in tariff’ is used for the total amount per kWh received by an independent producer of renewable electricity, including production subsidies and/or tax refunds [Huber 2001]. But in some cases, it refers to the premium price paid above or additional to the market price of electricity [Haas 2001].

In the following section, a simple mathematic method is presented to characterize and benchmark the strength of FITs of the selected seven countries in mitigating the global greenhouse gas emissions from fossil fuel power generation industry.

The objective of the proposed FITs in the international world is to promote the application of clean energy technologies in global power generation systems so as to reduce environmental impact of fossil fuel energy consumption. Due to the high cost of clean energy electricity [Yuan 2009], as calculated in cents/kWh, the price of produced clean power must be made competitive relative to the grid power in the market in order to be used by the society. The FIT incentives pay additional money to

cover the gap between the cost of clean power and the grid electricity. As a result, the mitigation of greenhouse gas emissions from fossil fuel power system is at an extra cost in terms of the FITs in the guaranteed paid time period.

By considering the benefits of the greenhouse gas emission mitigated and the total amount of additional costs paid through the FITs during the guaranteed paid time, here a simple mathematic method has been developed to assess the strength of FITs, with application on greenhouse gas emission mitigation for various countries.

In this method, the ratio of GHG emissions mitigated,  $G_i$ , by the use of clean energy source,  $i$ , to the extra dollars invested,  $D$ , is defined as the GHG emission mitigation benefit,  $B$ , as shown in the following equation:

$$B = \frac{G_i}{D} = \frac{(A_i * T_i)(G_i^G - G_i^R)}{F_i^w (A_i * T_i)} \quad (3-7)$$

Where

$F_i^w$ : FIT for the capacity bracket,  $w$ , of the source,  $i$

$A_i$ : annual output for the source in gigawatt-hours (GWh)

$T_i$ : guaranteed payment time frame for the FIT, years

$G_i^G$ : annual GHG emission from the grid, Kg CO<sub>2</sub>-eq/year,

$G_i^R$ : annual GHG emissions of the clean power source, Kg CO<sub>2</sub>-eq/year

---

As a result, equation (3-7) can be simplified into the following expression:

$$B = \frac{(G_i^G - G_i^R)}{F_i^W} \quad (3-8)$$

The simplified equation (3-8) is the formula employed in this research to characterize and benchmark the mitigation effect of greenhouse gas emissions by implementing FITs in various countries.

From equation (3-8), once the FITs are assessed and values for B are calculated, the use of a schematic diagram simplifies the process of benchmarking and allows for a quick understanding of the strength and potential emissions benefits of FITs, which could be used to facilitate the benchmarking of the strength of FITs of various countries and provide a rapid decision support tool for clean energy applications in different global regions for greenhouse gas emission mitigation.

### **3.5 Levelized Energy Cost analysis of Solar PV, Wind and Fuel Cell**

As the cost of solar PV is currently much higher than conventional grid power generation, the analysis of such economic parameter as Levelized Energy Cost (LEC) will provide references to decision makers with the minimum price at which energy must be sold for an energy project to break even. U.S. EIA reported the estimated levelized cost of new power generation resources by 2016 [US EIA 2011] By EIA's report, the LEC of solar PV (0.211 \$/kWh) will be still much higher than conventional

coal (0.095 \$/kWh) by 2016. In order for us to provide a comprehensive investigation on the application potential of solar PV in the future, the LEC analysis is also discussed in this research.

Levelized energy cost (LEC, also called Levelized Cost of Energy or LCOE) is a cost of generating energy (usually electricity) for a particular system. LEC can be calculated as the ration between the lifecycle cost and the lifetime energy production [Darling 2011]. It is an economic assessment of the cost the energy-generating system including all the costs over its lifetime: initial investment (overnight capital cost), fixed operations and maintenance (O&M), variable O&M. In this study, the levelized cost of solar PV is calculated over an assumed 25 years lifetime. It can be defined in the following equation:

$$LEC = 100 \times \left( C_{vOM}^i + \frac{C_o^i * P^i + C_{fOM}^i * P^i}{E} \right) \quad (3-9)$$

Where:

*LEC*: Average lifetime levelized electricity generation cost, cents/kWh

$C_o^i$  : Investment expenditures, Overnight capital cost, \$/kW

$C_{fOM}^i$  : Fixed operations and maintenance, \$/kW

$C_{vOM}^i$  : Variable O&M expenditures, \$/kWh

$P^i$ : Rated power of the power system, kW

*E*: Total electricity generated, kWh

### **3.6 Cost Benefit Analysis**

Using clean energy technologies for GHG emission mitigation in automotive manufacturing industry requires complex decision-making processes. Due to the fact that CO<sub>2</sub> has a long persistence time in the atmosphere, the CO<sub>2</sub> emission is a global issue no matter where it is generated. As a result, the automotive manufacturing industry needs to seek economical solutions to reduce their CO<sub>2</sub> emissions from their global manufacturing facilities, which requires the selection of appropriate clean energy technologies and the identification of the ideal geographical location of a specific manufacturing facility for the clean energy deployment.

Considering the major factors of industrial concerns on the application of clean energy systems in automotive manufacturing, the application potential of various clean energy technologies can be quantitatively assessed based on a cost benefit analysis. In this study, solar PV, wind and fuel cells are selected for analyzing and benchmarking their application potentials using a cost benefit analysis approach. The cost is the economic cost of the clean energy systems, and the benefit is the amount of the GHGs reduced.

Regarding economic costs of clean energy power systems, there are different economic parameters used for describing the costs of different clean energy technologies. Commonly used economic costs data for clean energy systems are



overnight cost, fixed operating and maintenance (fixed O&M) cost, variable operating and maintenance (variable O&M) cost, etc [US EIA 2010]. The overnight costs are the cost estimates to build a plant in a typical region of the country [US EIA 2010]; operating and maintenance costs are those costs associated with operations and maintenance of clean power systems during their service life, with some costs fixed and some varying. For different products in the clean energy power market, the overnight cost and the cost for operation and maintenance of the same type of power system may be different, but the difference become more and more negligible due to the globalization of the clean energy market. In general, the total cost of the virtual clean energy power system can be expressed by the following equation:

$$C_T^i = P^i (C_o^i + C_{fOM}^i) + E^i C_{vOM}^i \quad (3-10)$$

Where

$C_T^i$ : total cost of  $i^{\text{th}}$  clean energy power system in US\$,

$P^i$ : rated power of the  $i^{\text{th}}$  clean energy power system in kW,

$C_o^i$ : overnight cost of the  $i^{\text{th}}$  clean energy power system, in US \$/kW,

$C_{fOM}^i$ : fix operating & maintenance cost of the  $i^{\text{th}}$  clean system, in US \$/kW,

$C_{vOM}^i$ : variable operating & maintenance cost of the  $i^{\text{th}}$  clean system, \$/kWh,

$E^i$ : The total electricity output during the life time of the  $i^{\text{th}}$  clean energy power system, in kWh.

Using the economic cost metric in equation (3-10), a mathematical model based on conventional cost benefit approach can be developed for assessing the application potential of clean energy stationary power supply for GHG mitigations from automotive and similar manufacturing systems at different global locations. Here the model is developed with an aim to provide a simplified mathematical approach for the interested industry to support the decision-making and strategy-planning during the early stage of project assessment, budget-planning and goal definition for GHG mitigation from their global production facilities.

In this mathematic model, the benefit is defined as the amount of GHGs which can be reduced based on certain amount of economic input. From the perspective of applied industrial economics, the cost associated with the selected clean energy supply pattern should be minimal to achieve a pre-defined strategic goal of GHG reduction, or the reduced amount of GHG should be maximal based on a fixed amount of economic cost input. In this cost benefit model, all kinds of GHG emissions from electricity generations and supply are considered, including CO<sub>2</sub>, CH<sub>4</sub>, N<sub>2</sub>O, etc. The GHG emissions are characterized as the total amount of CO<sub>2</sub> equivalent. Those non-CO<sub>2</sub> emissions are transformed into CO<sub>2</sub> equivalent through their IPCC global warming potential (GWP) metric [IPCC 2007]. In this model, the conversion of D.C. power output from the clean energy power systems to conventional A.C. power supply is also considered in the actual power output. Overall operating efficiency of each clean energy power system corresponding to local geographical and environmental

conditions is also considered in the analysis. The mathematical expression of the cost benefit model is shown in the following:

$$G = \frac{(E_{local} - E_i) \times A_i \times T_i}{(C_{Ni} + C_{Fi}) \times A_i + C_{vi} \times (T_i \times A_i)} \quad (3-11)$$

Where,  $G$ : the amount of GHG reduction (ton/\$1,000)

$E_{local}$ : emission factor of GHGs from local grid power supply (kg/kWh)

$E_i$ : the life cycle GHG emissions of clean energy  $i$  (kg/kWh)

$A_i$ : total installed capacity of clean energy power system  $i$

$T_i$ : operational life time of clean power system  $i$  (h)

$C_{Ni}$ : overnight cost of clean power system  $i$  (\$/kW)

$C_{vi}$ : variable O&M cost of clean power system  $i$  (\$/kWh)

$C_{Fi}$ : fixed O&M cost of clean power system  $i$  (\$/kWh)

Using equation (3-11), the amount of GHG reduction per unit cost investment can be quantitatively determined for each clean energy technology corresponding to a specific location of manufacturing facilities in the global scale. With the same scale of measurement, the cost benefit performance can be benchmarked between different clean energy power systems to identify the best pattern of clean energy supply for a specific location of manufacturing facility.

### 3.7 Sensitivity Analysis

The mathematical methodology developed in this study involves quite a few parameters, including both meteorological and economic parameters. The sensitivity analysis helps with ordering the importance of strength of and relevance of the inputs, namely the geographic and economic parameters, in determining the variation in the outputs. The sensitivity analysis is essential to build quality assurance for the model.

Sensitivity analysis (SA) is the study of how the uncertainty in the output of a model (numerical or otherwise) can be apportioned to different sources of uncertainty in the model input [Saltelli 2008]. In more general terms uncertainty and sensitivity analysis investigate the robustness of a study. Sensitivity analysis can be useful for a range of purposes [Pannell 1997], including: Support decision making or the development of recommendations for decision makers (e.g. testing the robustness of a result); Enhancing communication from modelers to decision makers (e.g. by making recommendations more credible, understandable, compelling or persuasive); Increased understanding or quantification of the system (e.g. understanding relationships between input and output variables); etc.

In this study the Pearson Correlation method is selected to evaluate the sensitivities of the inputs. In statistics, the Pearson product-moment correlation coefficient is a measure of the correlation (linear dependence) between two variables  $X$  and  $Y$ , giving a value between  $+1$  and  $-1$  inclusive. It is widely used in the sciences as a measure of

---

the strength of linear dependence between two variables [Rodgers 1988, Stigler 1989].

Pearson's correlation coefficient when applied to a population is commonly represented by the Greek letter  $\rho$  and may be referred to as the population correlation coefficient or the population Pearson correlation coefficient. The formula for  $\rho$  is expressed by the following equation [Rodgers 1988, Stigler 1989]:

$$\rho_{XY} = \frac{\text{cov}(X, Y)}{\sigma_X \sigma_Y} = \frac{E[(X - \mu_X)(Y - \mu_Y)]}{\sigma_X \sigma_Y} \quad (3-12)$$

Where

$\rho_{XY}$  : Pearson's correlation coefficient

$X$  : Input variable

$Y$  : Output variable

$\sigma_X$  : Standard deviation of X

$\sigma_Y$  : Standard deviation of Y

$\mu_X$  : Expectation value of X

$\mu_Y$  : Expectation value of Y

Pearson's correlation coefficient when applied to a sample is commonly represented by the letter  $r$  and may be referred to as the sample correlation coefficient or the sample Pearson correlation coefficient. A formula can be obtained for  $r$  by substituting estimates of the covariances and variances based on a sample into the formula above. That formula for  $r$  is [Rodgers 1988, Stigler 1989]:

$$r = \frac{\sum_{i=1}^n (X_i - \bar{X})(Y_i - \bar{Y})}{\sqrt{\sum_{i=1}^n (X_i - \bar{X})^2} \sqrt{\sum_{i=1}^n (Y_i - \bar{Y})^2}} \quad (3-13)$$

Where

$X_i$  : Input variable

$\bar{X}$  : Expectation value of  $X$

$Y$  : Output variable

$\bar{Y}$  : Expectation value of  $Y$

The correlation coefficient is dimensionless number; it has no units of measurement.

The correlation coefficient has the following characteristics:

- (1)  $-1 \leq r \leq 1$ ;
- (2) The value  $r=1$  and  $r=-1$  occur when there is an exact linear relationship between  $x$  and  $y$ .
- (3) If  $y$  tends to increase in magnitude as  $x$  increases,  $r$  is greater than 0,  $x$  and  $y$  are said

to be positively correlated. ( $r > 0$ )

(4) If  $y$  decreases as  $x$  increases,  $r$  is less than 0 and the two variables are negatively correlated. ( $r < 0$ )

(5) If  $r=0$ , there is no linear relationship between  $x$  and  $y$  and the variables are uncorrelated. ( $r = 0$ )

---

## **CHAPTER4 APPLICATION POTENTIAL ANALYSIS OF SOLAR PV, WIND AND FUEL CELLS FOR GLOBAL AUTOMOTIVE MANUFACTURING INDUSTRY'S SUSTAINABILITY IMPROVEMENT (A CASE STUDY)**

### **4.1 Introduction**

As discussed in the above chapters, the energy demand of automotive manufacturing is significant [Yuan 2006]. As estimated, the manufacture of a typical vehicle requires approximately 120 Giga Joules of energy input [Maclean 1998]. Electricity is one of the major types of energy supply for automotive manufacturing. Greenhouse Gases (GHGs) are generated in the process of automotive manufacturing. Greenhouse Gas Emissions are generated from both the direct on-site consumption of fossil fuel energy and indirectly from consumption of purchased electricity.

Aware of the significance of global warming resulting from GHG emissions into the atmosphere, the global automotive industry has worked intensively to reduce the GHG emissions from their production facilities as well as manufacturing processes. For instance, the Alliance of Automobile Manufacturers (AAM), formed by such major global automotive manufacturers as GM, Ford, Chrysler, Toyota, Mitsubishi, Mercedes, Porsche, Volkswagen, Volvo, and Jaguar, committed to achieve a 10% reduction in greenhouse gas emissions per number of vehicles produced from their



U.S. automotive manufacturing facilities by 2012 measured from a base year of 2002 [US DOE 2007]. By the previous statistics, during the time period between 2002 and 2005, the AAM members have already reduced the GHG emissions intensity of their U.S. facilities, measured as CO<sub>2</sub> emissions per number of vehicles produced, by nearly 3% [US DOE 2007].

The General Motors Company, as one of the leading global automotive manufacturers, in 2007, consumed a total of  $5.543 \times 10^{16}$  Joules energy in its U.S. facilities, which included  $2.149 \times 10^{16}$  Joules of energy supply from purchased electricity [GM 2008]. The total energy consumption of GM generated 6.263 million metric tons of CO<sub>2</sub> emissions, which included 4.359 million metric tons' portion from purchased electricity [GM 2008]. In reducing the GHG emissions, GM has implemented energy efficiency improvement efforts and conversions to lower GHG emitting fuels such as switching from coal to natural gas for the operation of boilers [GM 2008]. In statistics, GM facilities have participated in a total of 1753 improvement projects from 1991–2007, which led to a total reduction of GHG emissions of over 17 million metric tons CO<sub>2</sub> equivalent [GM 2008]. Through such efforts, GM has significantly improved the capacity utilization of its facilities operations. In terms of the CO<sub>2</sub> emission intensity of its facilities in the United States, GM has decreased its CO<sub>2</sub> emission per vehicle built from 2.71 metric tons per vehicle in 1990 to 2.2 metric tons per vehicle in 2007 [GM 2008]. However, despite such significant efforts in GHG mitigation, the total CO<sub>2</sub> emissions from GM's U.S. facilities still stand at over 6.0 million metric tons each year, due to the large volume of production [GM 2008].

The current issue is that further reduction of GHG emissions from GM's production facilities is difficult since approximately 70% of the total energy consumption is from purchased electricity, as shown in Figure 4.1 [GM 2008].

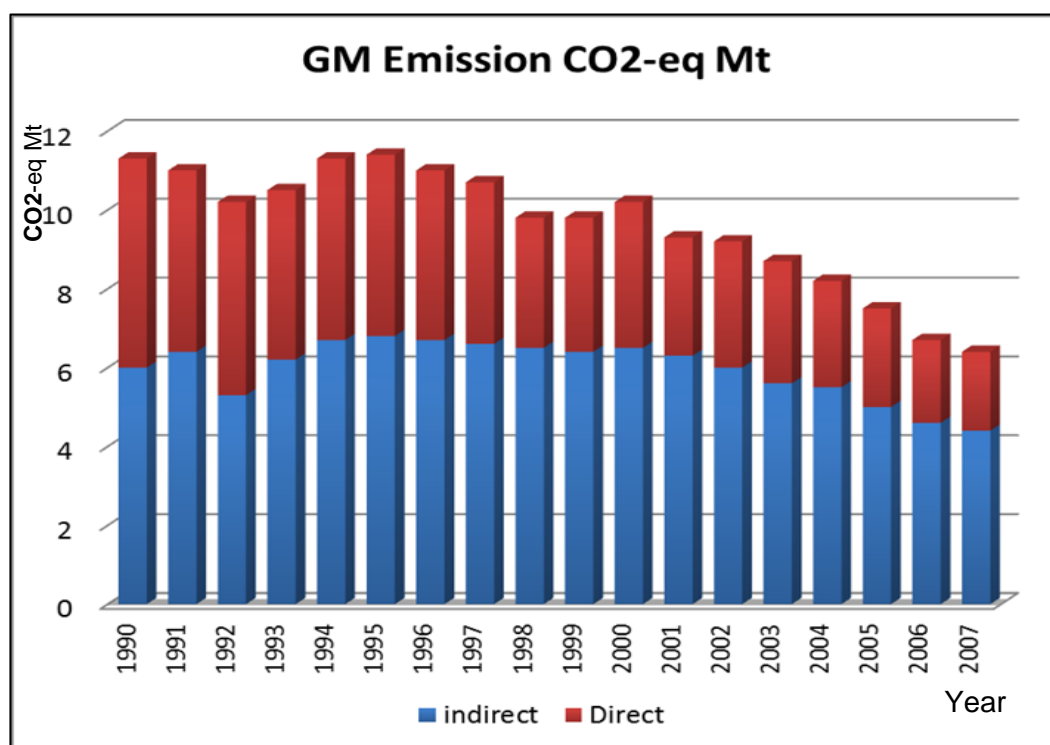

Figure 4.1 GM's Total energy usage for U.S. operations 1990-2007 [Data Source: GM 2008]

As the current electricity supply relies heavily on fossil fuel energy sources, further reduction of GHG emissions could be possibly achieved by using clean energy supplies to partially replace the current grid power supply of automotive production facilities, since the GHG emission intensity of clean energy technologies are much

less than that of grid power supply [Yuan 2009]. In order to aid the global automotive industry in understanding the potential application of clean energy technologies in reducing the GHG facility emissions, a quantitative study is conducted in this in cooperation with the General Motors Company on assessing the potential application of clean energy power systems in the efforts of GHG emission mitigation from the production facilities of global automotive manufacturers.

There are quite a few clean energy technologies for power generation available on the commercial market. Considering the specificity and requirements of automotive production facilities as well as the maturity and adaptability of the various clean energy technologies, three such clean energy power systems, namely solar PV, wind and fuel cells have good potential in stationary power supply and GHG emission reduction for automotive manufacturing industry [Yuan 2009]. In this study, a number of representative power systems are selected based on these three clean energy technologies to assess their potential application in GHGs mitigation at automotive manufacturing facilities located at different global geographic locations.

As a result of economic globalization, the production facilities of major global automotive manufactures are spread all over the world, with very different geographical conditions and power supply situations. For instance, GM as a leading global automotive manufacturer has its production facilities in 31 countries and has its business operations in 157 countries throughout the world [GM 2010]. In this study,

six representative locations are selected from GM's major global production facility list to represent the six different regions of the world. These locations include Detroit (United States), Mexico City (Mexico), Sao Paulo (Brazil), Shanghai (China), Cairo (Egypt) and Bochum (Germany), as shown in Figure 4.2 below:



Figure 4.2 Six selected geographical locations of GM production facilities.

In this study, the application potential of using the three clean energy technologies, namely solar PV, wind, and fuel cells, was quantitatively assessed for their application in reducing the GHG emissions of automotive manufacturing facilities. The application potential analysis results are objected for providing decision support of global automotive manufacturers in considering the appropriate clean energy

technologies and optimizing the GHG mitigation performance of the same economic investment.

The three clean energy technologies are benchmarked on their technology aspects, application potential (in terms of economic costs of GHG reduction) in the six selected global locations, possible reduction range of GHG emission reduction in the selected countries as well as the cost benefit distribution in the US lower 48 states. The analyses results presented in this study will be useful in providing detailed quantitative information, integrating the technology characteristics of clean energy power systems and geographical differences of local power generation and supply conditions, for robust decision support in GHG emission mitigation by the global automotive and similar manufacturing industries with large amount of production volume.

Here details are presented on using the developed mathematical models to analyze the representative solar PV, wind and fuel cells stationary power systems for GHGs mitigation from GM's global automotive manufacturing facilities at the six selected representative locations, namely Detroit (United States), Mexico City (Mexico), Sao Paulo (Brazil), Shanghai (China), Cairo (Egypt) and Bochum (Germany). With the case study, the application potential of each clean energy technology at each location is quantitatively determined and benchmarked, aiming to provide decision support in the early stage of strategic-planning and priority-setting for employing clean energy supply in automotive and similar global manufacturing industry.

## 4.2 Data Collection

In this study, the meteorological data and the technical data are mainly collected from the public resources, such as publications and major credible online resources. Here the data collected for applying the mathematical model are briefly introduced in the following section.

### 4.2.1 Meteorological data Collection

The monthly averaged amount of the total solar radiation incident on a horizontal surface at the surface of the earth for a given month, averaged for that month over the 22-year period (Jul 1983 - Jun 2005) is evaluated as the numerical average of 3-hourly values for the given month [NASA 2008]. The monthly averaged air temperature for a given month is averaged for that month over the 22-year period (Jan 1983 - Dec 2004). Temperature values are for 10 meters above the surface of the earth. Each monthly averaged value is evaluated as the numerical average of 3-hourly values for the given month [NASA 2005]. The monthly average wind speed for a given month, averaged for that month over the 10-year period (July 1983 - June 1993). Wind speed values are for 50 meters above the surface of the earth. Each monthly averaged value is evaluated as the numerical average of 3-hourly values for the given month [NASA 2005]. The collected meteorological data are presented in table 4.1.

	Detroit	Mexico City	Sao Paulo	Shanghai	Cairo	Bochum
Latitude	42	19	-23	31	30	51
Longitude	-83	-100	-46	121	31	7
Altitude(m)	180	2700	640	7	20	120
Insolation, (kWh/m <sup>2</sup> day)	3.48	5.18	4.55	3.87	5.29	2.70
Temperature, ( °C)	9.19	16.47	21.47	15.56	21.04	9.54
Wind speed (m/s)	5.61	3.74	3.99	5.59	4.76	6.63

Table 4.1 Meteorological Data of Six Global Locations [NASA 2005, 2008]

#### 4.2.2 Economic and environmental data of the representative clean energy technologies

On the global commercial market, there are a variety of clean energy technologies available for power generations and supply. These different products have different technical specifications which can lead to different power output and different cost benefit in the same application scenario. In order to make the analysis results comprehensive and representative, in this case study a number of the most popular clean energy power systems are selected and their average technical specifications are used as representative specifications of current technologies on the commercial market.

In this study, a total of five multi-crystalline silicon solar PV modules are selected, which are the top five modules in terms of both production volume and installed

capacity in the world [REW 2011]. The technical characteristics are shown in Table 4.2. For wind power system, four wind turbines at 1.5 Mega-watt are selected, including GE 1.5XLE, Sinovel SL1500/77, Suzlon S82 1.5MW and Nordex S77 1.5MW, as shown in Table 4.3. These four wind power systems have the largest installation capacity throughout the world [MWPS 2010].

Solar PV Module	Manufacturer	Rated Power (W)	Eff. (%)	Surface Area (m <sup>2</sup> )
Suntech STP210-18/Ud	Suntech	210	14.30	1.47
Sharp ND-224uC1	Sharp	224	13.74	1.63
Qcells Q.BPPARROSOE 225	Q-Cells	225	17.00	1.67
YL 210 P26b/1495x990	Yingli Solar	210	14.20	1.48
Trina Solar TSM-PC05	Trina Solar	230	14.70	1.64

Table 4.2 Selected Solar PV Modules for Power Supply in Automotive Manufacturing [Zhai 2011]

	Manufacturer	Rated Capacity(kW)	Rotor Diameter(m)	Swep Area(m <sup>2</sup> )	Hub Height(m)
GE 1.5XLE	GE	1500	82.5	5346.00	80
SL1500/77	Sinovel	1500	77.4	4705.13	82
S82 1.5MW	Suzlon	1500	82	5281.02	78
S77 1.5MW	Nordex	1500	77	4656.63	80
Mean			79.73	4992.05	80

Table 4.3 Selected wind turbine systems [Zhai 2011]



In current stage, fuel cells are mainly developed as mobile energy sources for transportation applications. For stationary power generations, there are only a few models available in the United States. In this analysis, two fuel cells stationary power systems are selected, with one system using hydrogen fuel, the other one using natural gas. The selected fuel cell power systems are Nedstack PS100 (Hydrogen, rated at 100 KW) and UTC Purecell200 (natural gas, rated at 200 KW), respectively, as shown in Table 4.4.

Stationary Fuel Cells	Manufacturer	Fuel Type	Rated Power (kW)
PureCell 200	UTC Power	Natural gas	200
Nedstack PS100	Nedstack	Hydrogen	100

Table 4.4 Selected fuel cell stationary power system for electricity generation [Zhai 2011]

The economic costs of the selected clean technologies are shown in Table 4.5. The economic costs of these clean energy systems are compiled in 2010 by U.S. EIA [US EIA 2010]. The LCA GHGs emission factors of these clean power systems are collected from literature, as shown in Table 4.5. The data demonstrates that among these four clean energy power systems, wind has the lowest overnight cost and lowest life cycle GHG emission factor, while solar PV and fuel cell power systems are much more expensive in the system deployment and have much higher GHG emission factors due to their complex system structure and deployment processes. The emission

factors of US, Mexico, Brazil, China, Egypt and Germany are 680, 594, 93, 845, 437, 542 g CO<sub>2</sub>eq /kWh [US EIA 2007], as shown in Table 4.6.

Clean energy	Overnight Cost (\$/kW)	Fixed O &M Cost (\$/kW)	Variable O&M Cost (\$/kWh)	Life cycle GHG emission factor
Solar PV	4697 <sup>1</sup>	25.73 <sup>1</sup>	0.00 <sup>1</sup>	72.4 <sup>2</sup>
Wind	2409 <sup>1</sup>	27.73 <sup>1</sup>	0.00 <sup>1</sup>	10.84 <sup>3</sup>
Fuel Cells (N)	6752 <sup>1</sup>	345.8 <sup>1</sup>	0.00 <sup>1</sup>	683 <sup>4</sup>
Fuel Cells(H)	10735 <sup>6</sup>	2147 <sup>6</sup>	0.00 <sup>6</sup>	83 <sup>5</sup>

Table 4.5 Economic and environmental data of the representative clean energy technologies

<sup>1</sup> Multicrystalline Si Solar PV, onshore wind and natural gas based fuel cells, costs data from reference [US EIA 2011]

<sup>2</sup> Multicrystalline Si Solar Cell, LCA result from reference [Pehnt 2006]

<sup>3</sup> 1.5MW onshore wind Turbine, LCA result from reference [Pehnt 2006]

<sup>4</sup> Stationary Fuel Cell (natural gas), LCA result from reference [Jaap 2006]

<sup>5</sup> Stationary Fuel Cell (hydrogen), LCA result from reference [Viebahn 2003]

<sup>6</sup> The cost data for hydrogen PEM fuel cells, from reference [Gerboni 2011]

Region	Emission Inventory (g/kWh)			
	CO <sub>2</sub>	CH <sub>4</sub>	N <sub>2</sub> O	CO <sub>2</sub> eq <sup>3</sup>
USA <sup>1</sup>	676	0.01815	0.01053	680
Mexico <sup>2</sup>	593	0.01676	0.00230	594
Brazil <sup>2</sup>	93	0.00251	0.00106	93
China <sup>2</sup>	839	0.01458	0.01841	845
Egypt <sup>2</sup>	436	0.01365	0.00177	437
Germany <sup>2</sup>	539	0.00637	0.00779	542

Table 4.6 GHG emission factors of local grid power supply.

<sup>1</sup> The U.S. electricity emission factors are from reference [US EIA 2007].

<sup>2</sup>The international electricity emission factors are from reference [US EIA 2007].

<sup>3</sup>The CO<sub>2eq</sub> are calculated based on the GWP values from reference [IPCC 2010].

### 4.3 Technological Feasibility Analysis

Before the conduction of cost benefit analysis, each selected clean energy power technology is investigated technically. Using equation (3-1), the technical feasibility of each individual clean energy system is analyzed for the six selected global locations. With substituting the collected life cycle GHG emission factors into equation (3-1), the feasibility of each clean energy power system for GHG mitigation at each of these six selected locations are quantitatively investigated. The calculated results are shown in Figure 4.3 below.

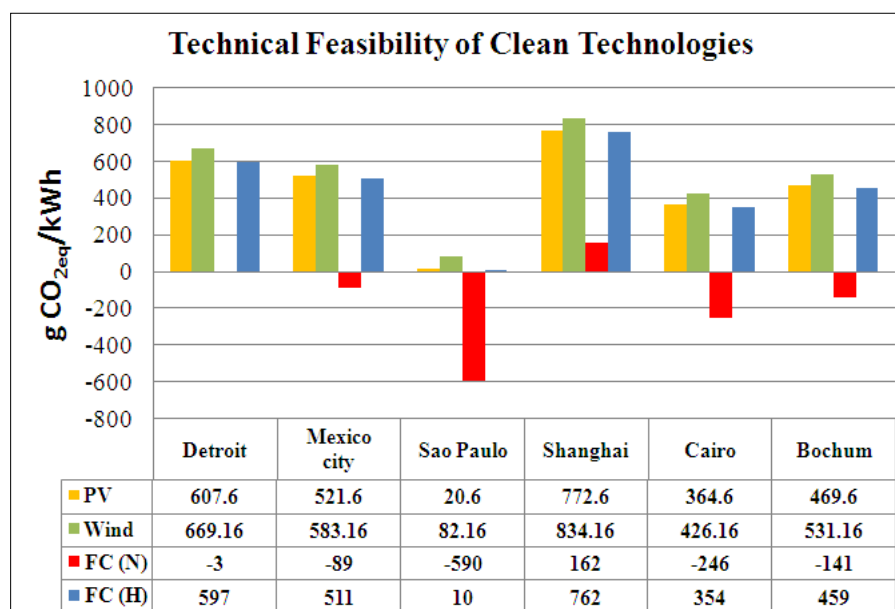

Figure 4.3 Feasibility analyses of clean energy technologies at the six selected global locations

---

Figure 4.3 demonstrates that solar PV, wind, and hydrogen-based fuel cell technologies all have certain potentials for practical applications as clean energy supply for GHG mitigations at all these six locations, while the natural gas-based fuel cell power system is only technically feasible in Shanghai (China) because of the high local GHG emission factor from the conventional grid (845 g CO<sub>2,eq</sub>/kWh).

Among all these six locations, wind energy has the highest potential in terms of absolute amount of GHG mitigation when compared with the other clean power systems. Solar PV and hydrogen-based fuel cell power systems are roughly at the same level because of the small differences of the life cycle GHG emission factors from the two power systems. The results in Figure 4.3 also demonstrate that, per unit amount of power generation, wind power system in Shanghai (China) has the potential to reduce as high as 834 g CO<sub>2,eq</sub> per kWh of electricity consumed, five times more than the reduction from natural-gas-based fuel cell power system at the same location. But for the actual GHG mitigation effects, it also depends on the actual power system outputs which rely on local geographic conditions for solar PV and wind technologies, which will be demonstrated in the following cost benefit analysis.

#### **4.4 Capacity Factor**

Although the energy density information can serve as the basic indicator of the application potential of clean energy power systems, further analyses are needed to

---

understand more about the practical implementation of these clean energy power systems in different geographical locations. For solar and wind energy, the capacity factor, a meaningful metric is employed to assess their actual application potential in a specific geographic location, to assess the performance of the clean energy systems at the selected locations.

As discussed in the above chapter, the capacity factor is defined as the ratio between the actual power output and the total rated power of the system available for the power generations. The calculated capacity factors for solar PV and wind power systems at the six selected geographical locations are shown in Figure 4.5. The actual power output for solar PV system is calculated by multiplying the local annual solar insolation, the module area, module numbers, module efficiency and the DC to AC conversion efficiency. The actual power output for wind turbine system is calculated by substituting the actual wind speed at hub height into the interpolated wind power curve.

The actual power output for wind turbines is calculated by applying the power curve of the wind turbine model. The power curve of each model of wind turbine is fitted by the power output values at different wind speeds supplied by the wind turbine manufacturer. The interpolated power curves of the selected wind turbines are presented in Figure 4.4.

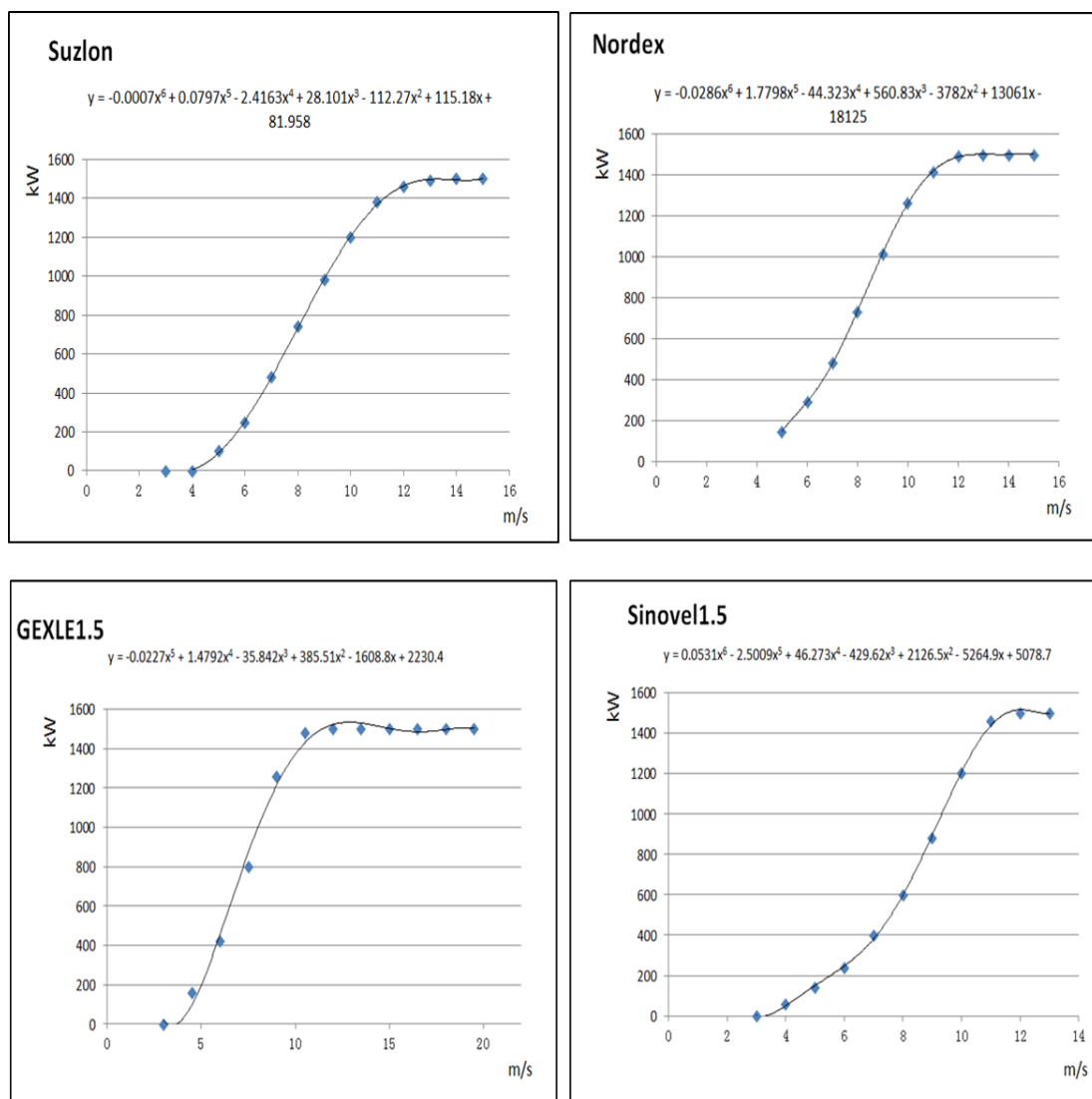

Figure 4.4 Interpolated Power Curves of selected wind turbines

The results in Figure 4.5 demonstrate that for current solar PV power systems, the actual capacity factors are all below 20% at these six selected locations; while the capacity factor of wind can reach up to 47% at these selected locations, depending on the local wind energy resources. Figure 4.5 indicates that Cairo has the largest capacity factor for solar PV at 17.98%, followed by Mexico City (17.62%) and Sao Paulo (15.48%). The capacity factors for solar PV in Shanghai, Detroit and Bochum

are 13.15%, 11.84% and 9.19%, respectively. From the comparison of the capacity factors at the six locations, it can be concluded that Cairo has the largest technical potential, followed by Mexico City, Sao Paulo, Shanghai, Detroit and Bochum.

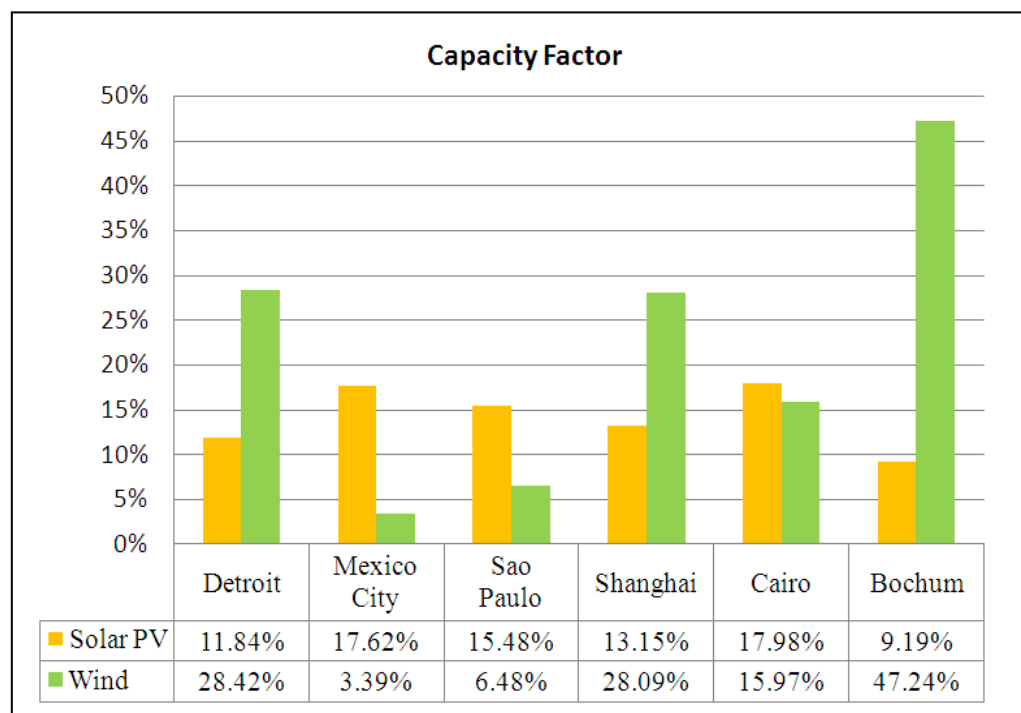

Figure 4.5 Capacity factors of solar PV and wind power systems at the six selected locations.

For wind power systems, Figure 4.5 demonstrates that Bochum has the largest wind capacity factor at 47.24%, followed by Shanghai (28.09%), Detroit (28.42%), Cairo (15.97%), Sao Paulo (6.48%) and Mexico City (3.39%). For the Equation used in capacity factor calculations, the rated power is used as the denominator, which means for the same amount of rated power, the larger the output power is, the larger the

---

capacity factor will be. For a wind turbine, as discussed in the above chapters, the input power can be simply estimated by the following equation:

$$P_i = D_w \times A_s$$

The above equation indicates that the larger the wind power density, the larger the input power. Obviously, for two wind turbines with the same efficiency, the output power is positively correlated with the input power under the wind speed conditions before the rated power is reached. From this point of view, the geographical locations with a high wind power density can lead to a large power output of a wind turbine and accordingly produce a large capacity factor. In the energy density analysis, the results demonstrate that Bochum has the highest wind power density, followed by Shanghai, Detroit, Cairo, Sao Paulo and Mexico City.

#### **4.5 Strength Analysis of International Feed-in Tariff Promotion of Clean Energy Applications for Greenhouse Gas Emission Mitigation**

In this dissertation, a case study with comparison of FITs and their potential mitigation effect on the greenhouse gas emissions for the selected seven countries, including United States (US), Germany (DE), South Africa (SA), China (CH), Italy (IT), Iran (IR), and South Korea (SK). The selection of these seven countries is not exactly the same as the selection of the countries in other sections of this chapter,



which is because of the lack of data. However, these countries were chosen in such that they provide a broad representation of the global geography. The greenhouse gas emission data of these countries are collected from various public sources [WEC 2004] [US EIA 2002, 2009].

This study is conducted in collaboration with General Motors (GM) with the purpose of understanding the role of FIT incentive policies in the mitigation of GHG emissions and partially to provide decision feedback for policy-makers on such incentive programs in the international world.

Due to the differences in energy structure and economic pattern of each country, the FITs adopted by different countries are different. As a result, the strengths of FITs in promoting the application of clean energy power technologies are different from different countries. Since greenhouse gas emissions are global issues, the generated amounts from different countries of the world finally contribute to the same global warming problem. In this research, the strength of international FITs in promotion of clean energy applications is analyzed in different regions of the world. The following seven countries are selected as representative of each region: including United States (US), Germany (DE), South Africa (SA), China (CH), Italy (IT), Iran (IR), and South Korea (SK). A simple mathematic method is developed and implemented on the FITs of these seven countries for characterizing and benchmarking the strength of their FIT

---

incentives in promoting the applications of solar and wind clean energy technologies for reducing greenhouse gas emissions from power industry.

In order to demonstrate the evolution and improve the understanding of FITs which are proposed and implemented in the world, in this section the FITs of Germany and United States are described in details as two examples of the seven countries.

Feed-in tariffs in Germany was first officially introduced on January 1, 1991 when the so called 'Electricity Feed Law' (EFL) went into effect. By the regulation of the EFL, the grid companies purchase renewable electricity from eligible sources and pay the producers concerned an annually fixed feed-in tariff [Haas 2001]. For solar and wind generated power, the tariff was set at 90 percent of the average electricity utility rate per kWh of all final consumers charged over the last but one calendar year [Haas 2001]. In April 2000, EFL was revised and replaced by 'Renewable Energies Law' (REL); by REL, the purchase and price of electricity generated in the territory of the Federal Republic of Germany was regulated, from specified renewable sources (i.e. hydropower, wind energy, solar energy, landfill gas, sewage gas, and biomass) [Haas 2001]. From 2000 to 2008, the renewable energy generated power in Germany increased from 6.3% to 15%, in the electricity mix [Haas 2001].

The FIT situation in the United States is a little different from Germany. During the past decade, renewable energy policy has made great progress in the US, but mainly

at the state level. There are currently 26 states with mandatory renewable portfolio standards (RPS) in the United States [Rickerson 2008]. Another six states have established non-binding renewable energy goals. US federal policy makers are looking at new ways to accelerate renewable energy development so that US can meet increasingly aggressive environmental and economic development goals [Rickerson 2008]. Among the emerging policy mechanisms that are particularly being considered are feed-in tariffs [Rickerson 2008].

Besides Germany and United States, Feed-in Tariffs have also been successfully implemented in the other five countries including Italy, South Korea, China, Iran and South Africa in 1992, 2003, 2005, 2009 and 2009, respectively [Rickerson 2008].

So far, the FITs proposed and implemented in different countries are totally different. The strength of FITs in promoting application of clean energy systems in each country is also very different. As a result, the mitigation effect of greenhouse gas emissions from power industry using solar and wind such clean energy technologies are different from country to country.

#### 4.5.1 FIT data by countries

In the practice, different countries employ different FIT incentives for wind and solar clean energies. In order to assess their strength in mitigating the greenhouse gas

emissions by promoting clean energy applications in power production industry, the FIT data for the selected seven countries are collected first as a database to perform strength analysis using equation (3-8). The collected FIT data for solar and wind (all converted to USD/KWh) are shown in table 4.7 below. The detailed description for data collection of each country is provided in the section below.

Region	Tariff(USD/KWh)	
	Wind	Solar
U.S.	0.25	0.5
Germany	0.1251	0.4486
Italy	0.40779	0.67965
Korea	0.115707	0.448569
China	0.07735	0.297
South Africa	0.160943	0.270384
Iran	0.12661	0.12661

Table 4.7 Comparison of Different FITs by Countries [Gipe 2010] [Zhai 2010]

The FITs data are from [Gipe 2010]. For the U.S, since there is no federal FIT available, FIT of Michigan is selected as a reference, where the automotive manufacturing center, Detroit is located. For China, the Solar PV tariff of Jiangsu province is selected as a reference. Among the tariffs of both PV and wind, the tariff of larger capacity is chosen as reference, since a positive increasing of PV and wind

---

capacities is expected in the future. For Germany, the on-land, 20 year data are selected for wind and rooftop (>1000MWh) for solar PV. For Iran, the tariffs for all renewables are the same, from which the peak and medium load data are selected as reference. For Italy, the >1000 MWh/yr for solar PV and <100KW for wind are selected. For South Korea, >3KW for solar PV is selected, and there is only one tariff for wind models. For South Africa, the FIT of concentrating solar is selected as representative of solar PV, and there is only one tariff for all wind models.

#### 4.5.2 Comparison of the GHG emissions reduction by Solar PV and Wind

In the mathematic equation (3-8), the numerator of the equation is the difference of greenhouse gas emissions between the grid power and clean energy power system (solar and wind) on the same functional unit base. As discussed in previous section, clean energy power systems are quite clean in their usage phase but not in other life cycle stages. In consideration of the greenhouse gas emissions from solar and wind power systems, their life cycle emissions should be used in order to conduct a comprehensive assessment.

Here the greenhouse gas emission factors of grid power are collected, in the unit of metric tons CO<sub>2</sub> equivalent per Mega-watt-hours, for the selected seven countries, as shown in table 4.8 below [WEC 2004]. For easy comparison, the life cycle emission

inventory of greenhouse gas for solar and wind clean energy power systems are also collected on the same unit and shown in table 4.5 [WEC 2004].

By comparing the differences between the greenhouse gas emissions factors of grid power and clean energy (solar and wind) systems, the amount of greenhouse gas emission which could be mitigated by applying FITs in the selected seven countries can be quantitatively determined and compared, based on the collected data.

Region	Greenhouse gas emission factors (metric tons CO <sub>2</sub> eq/MWh)		
	Grid Power	Wind	Solar
U.S.	0.6795917	0.0124	0.0125
Germany	0.5414807	0.0069	0.051
Italy	0.5264159	0.0124	0.051
Korea	0.4949416	0.0124	0.051
China	0.8448507	0.0124	0.051
South Africa	0.9158722	0.0124	0.051
Iran	0.5995309	0.0124	0.051

Table 4.8 Greenhouse gas emission factors of the seven countries for FIT analysis

[Data source: WEC 2004]

Note: the solar GHG emission factors of Korea, China, South Africa, and Iran are estimated as the same with that of Germany; the wind GHG emission factors of Italy, Korea, China, South Africa and Iran are taken the ECLIPSE, onshore data from [WEC 2004].

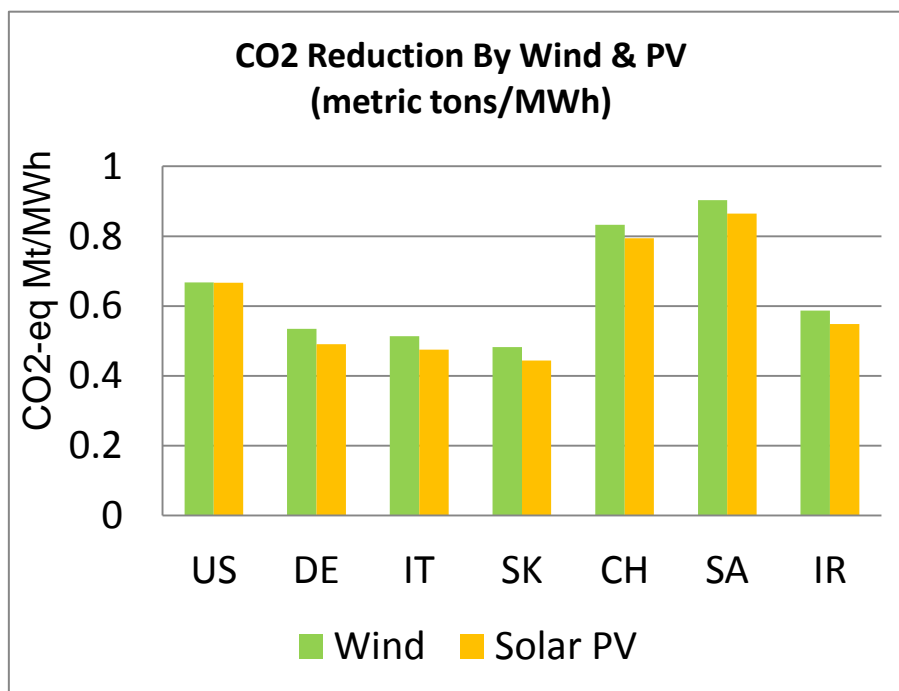

Figure 4.6 GHG emission mitigations through Solar PV and wind by countries

The results from Figure 4.6 indicate that the greatest reduction in greenhouse gas emissions per Mega-watt-hour clean energy generated under FIT incentive is in South Africa, next in China, followed by United States, Iran, Germany, Italy and Korea. When the same FIT applies, the greatest benefits from greenhouse gas emission mitigation using clean energy power system would be in South Africa and China these two countries.

The reason behind the phenomenon is that fossil fuel is the major energy source of South Africa and China. Approximately 88% of energy in South Africa [South Africa.info 2011] and 70% of energy in China are supplied by coals. While in South Korea, coal only produces approximately 24% of total energy [US EIA 2010], even

---

less than half of that of U.S. which is about 49% in the energy supply structure [US EIA 2006].

#### 4.5.3 Calculating the strength of FITs in greenhouse gas emission mitigation

With the FIT data collected and the amount of the greenhouse gas emission mitigation computed on a unit basis, the strength of FITs in promoting the applications of clean energy power systems for reducing greenhouse gas emissions can be directly calculated from current energy production and supply industry.

The strength of FIT incentives in mitigating greenhouse gas emissions in each country, are calculated for solar and wind clean power systems separately. To facilitate understanding of the plot and benchmarking of the results, the calculated greenhouse gas emission mitigation benefits are presented together with the FITs for solar and wind, respectively.

Figure 4.7 below shows the FITs and emission benefits of solar PV for the selected seven countries. The results indicate that for solar energy mitigation, Iran has the highest potential of mitigation to reduce the greatest amount of greenhouses gas emissions on the same economic incentive base among the selected seven countries. In the next are followed by South Africa and China, then U.S., Germany, South Korea and Italy.



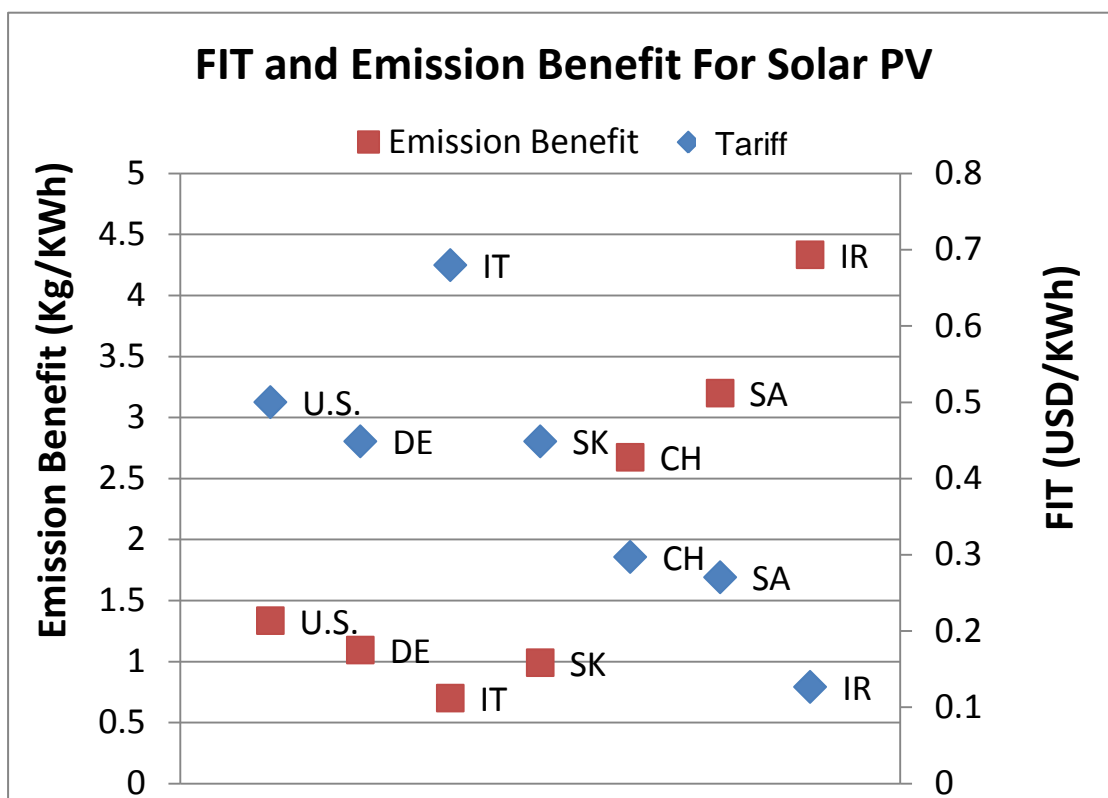

Figure 4.7 FIT and emission benefit for solar PV

The results reflected in Figure 4.7 are the indicator of greenhouse gas mitigation benefits of solar energy applications resulting from the FIT economic input. From the sustainable point of views, the greenhouses gas mitigation benefits are preferred to be as high as possible while the economic input is preferred as low as possible. For solar energy situation, Iran provides the smallest FIT incentive among these seven countries, while Italian the highest. For China and South Africa, their large amount of greenhouse gas emissions from grid power due to the high share of coal in energy structure make the absolute amount of mitigation much larger than other countries.

---

Figure 4.8 below shows the calculated results of wind FITs and greenhouse gas emission mitigation benefits for the selected seven countries. The results demonstrate that China and South Africa are the two countries which have the highest mitigation benefits for employing wind power based on the same amount of economic incentive input. This is mainly due to the fact that these two countries have an energy supply structure with coal sharing a very high percent of total energy production. Also, as demonstrated in Table 4.7 and figure 4.8, the Italian FITs for wind power provides the highest guaranteed price paid among these seven countries, and it has the relatively lower potential benefits than the other six countries. For U.S., Germany and South Korea, the strength of supporting wind energy are relatively higher, so they have relatively lower benefit potential for greenhouse gas emission mitigation.

As clean power systems are more and more widely used in global energy production system, there would be significant reduction of greenhouse gas emissions per unit energy consumption. The reduction would be particularly significant for those industries with direct fossil fuel consumptions. Although the clean energy power systems are environmentally beneficial, their high cost in electricity generation hinders their wide application in both industry and society. As a result, promotion of clean energy power systems through certain financial incentive programs such as FIT in current stage is necessary and functional in the international world.

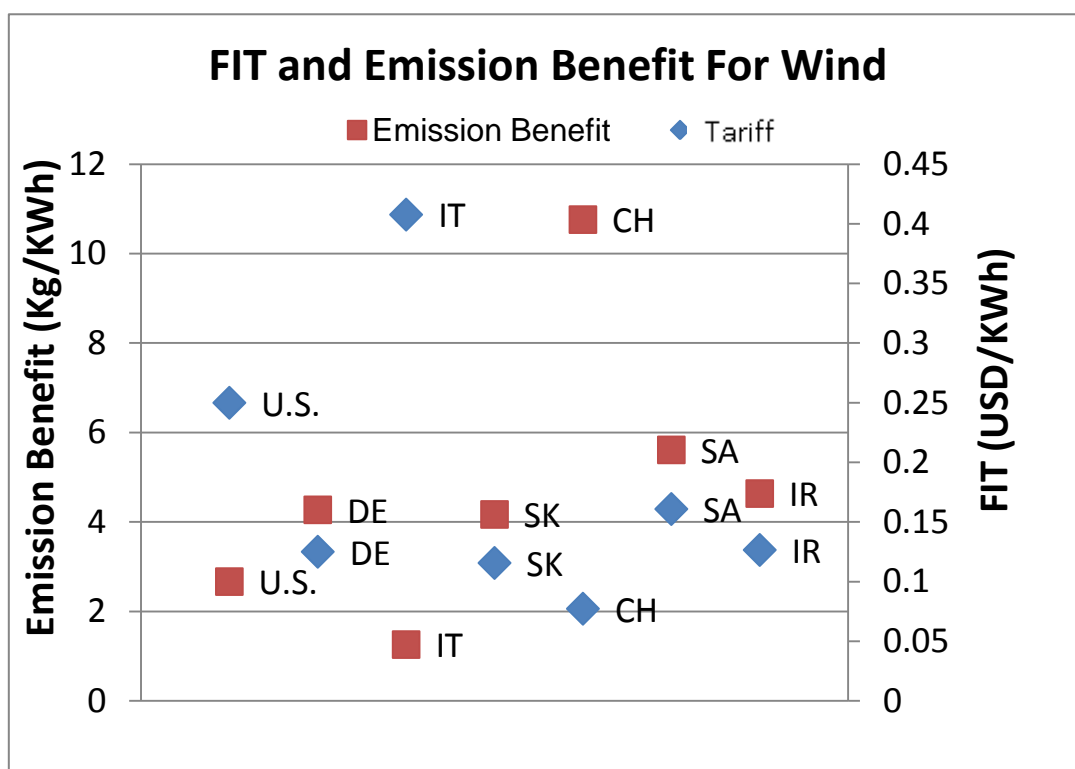

Figure 4.8 FIT and emission benefit for wind

Due to the differences in energy structures and economic patterns of different countries, the FITs provide different incentives in different regions of the world. These different FITs have different strength in promoting the applications of clean energy power systems in each country in regards to mitigating the greenhouse gas emissions resulting from fossil fuel energy consumptions. However, greenhouse gas emissions are global problems due to their long residence time in the atmosphere. Any emission of a greenhouse gas from different regions, if in the same quantity, would generate the same impact on global warming.

Mitigation of greenhouse gas emissions by using solar and wind such clean energy power systems would be significant for the sustainable improvement of industrial

prosperity and social progress. While from sustainable point of view, the mitigation of greenhouse gas emissions through the promotion of such financial incentives as FITs in the international world is usually preferred with the lowest cost while the highest reductions, no matter where the mitigation efforts are going to be implemented. The economic cost is normally a key decision factor in selecting the mitigation approach and locations, especially during the decision-making processes of those international business operators and global manufacturers.

In this study, a mathematic method has been developed, with the support of General Motors Corporation, to benchmark the international clean energy incentive policies for the purpose of understanding the influence of such policies on the trends for mitigation of greenhouse gas emissions and the implementation of clean energy generation technologies. The FIT is but one of such mechanisms, but unlike renewable portfolio standards and the trading of certified carbon reductions, it provides incentives for direct reductions in greenhouse gas emissions through the implementation of clean energy sources. Using the developed analysis method and the schematic plot the strengths of the FITs can be easily benchmarked, as well as their potential for clean energy applications to reduce greenhouse gas emissions for the presented cases. Manufacturers can use this quantitative and graphical approach to facilitate the process of decision-making regarding which locations will benefit the most from clean power generations in terms of greenhouse gas emissions mitigation. Finally, a case study on FIT strength benchmarking among seven countries including

---

United States, Germany, South Africa, China, Italy, Iran, and South Korea is quantitatively conducted.

The mathematic method developed in this research is only useful for decision support in reducing total greenhouse gas emissions from global perspective of views, particularly in the case where only a limited budget available for reducing the amount of greenhouse gas emissions of those global manufacturers from their production facilities, manufacturing systems, supply chain, etc. The results testified are only for solar and wind power technologies which are currently used in energy productions, and the technology development uncertainties are not addressed in this simple mathematic analysis, which could make the results quite different when taking into consideration the reduced cost of clean energy power generations in the future and the gradual change of energy supply pattern of a specific location.

The seven countries selected for this study are only representatives of different regions, and just selected in such to characterize the differences in FITs and their promotion effects in employing solar and wind to reduce the carbon footprint resulting from grid power supply and direct fossil fuel consumptions. Due to the limit of data availability and the differences of clean energy technologies employed in these countries, the strength analysis and the benchmarking are only quantitative estimates of the actual effect of such international FITs. Large uncertainties might exist in the computed results as well as the cited data from public sources.

Even so, the developed mathematic model and the presented results in this study still provide an useful approach and preliminary data for decision support in understanding the differences of FITs around the world and clarifying their differences in the greenhouse gas emission mitigation potential through promoting the applications of such clean energy systems as solar PV and wind in different regions of the world. The analysis and results could be useful for international business operators and global manufacturers to locate the ideal place to maximize the reduction of greenhouse gas emissions with a limited budget and efforts.

#### **4.6 Levelized Energy Cost analysis of Solar PV, Wind and Fuel Cell**

The LECs are calculated by using mathematical equation (3-9). The calculation results of the LECs for Solar PV, Wind and Fuel Cell plants are shown as Figure 4.9. From the results, for wind energy, Mexico City has the largest LEC and Bochum has the smallest one. This result indicates that Bochum has the best economic application potential of wind energy, in terms of LEC indicator comparison.

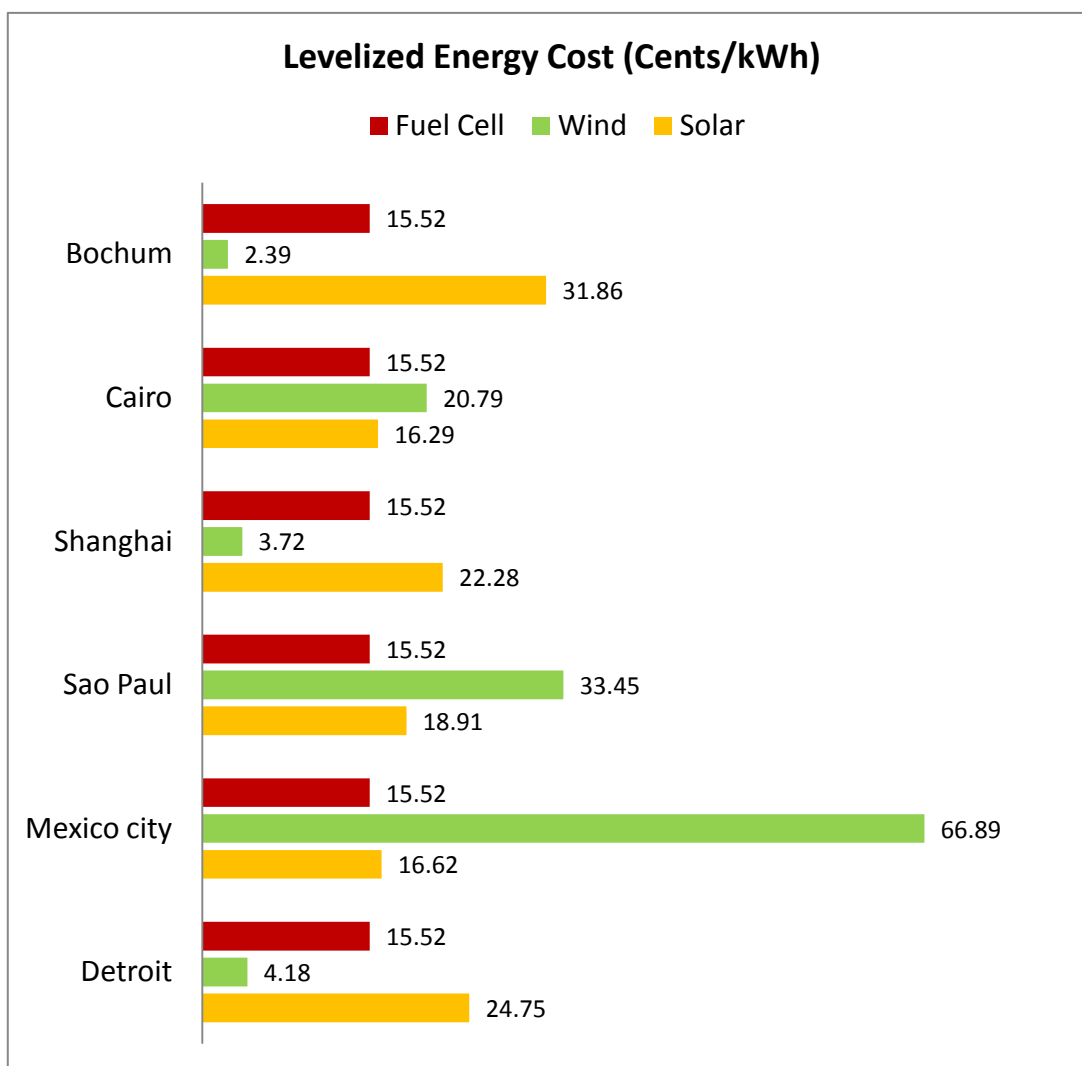

Figure 4.9 Levelized Energy Cost for Solar PV, Wind and Fuel Cell (NG)

Figure 4.9, indicates that, for solar PV, it has the smallest LEC in Cairo (16.29 cents/kWh), followed by Mexico City (16.62 cents/kWh), Sao Paul (18.91cents/kWh), Shanghai (22.28 cents/kWh), Detroit (24.75 cents/kWh) and Bochum (31.86 cents/kWh). The LEC is the minimum required price for the electricity to be retailed, therefore the smaller the LEC, the larger the application potential. For this consideration, Cairo has the largest application potential of Solar PV, followed by

---

Mexico City, Sao Paul, Shanghai, Detroit and Bochum. This analysis result is the same with the geographical and technical analysis results.

## **4.7 Cost Benefit Analysis**

### **4.7.1 Cost Benefit Analysis in the Six Selected Global Locations**

In this section, the cost benefits of each clean energy supply pattern at the six selected locations are assessed for quantifying and benchmarking the application potential of the three types of clean energy technologies for GHG mitigation in global automotive and similar large-scale manufacturing systems. In order to quantitatively analyze the cost benefit of the selected clean energy systems to supply the electricity needs of automotive manufacturing in different geographical locations, the amounts of the GHG reduction are quantified individually for the solar PV, wind, natural-gas based fuel cells, and hydrogen-based fuel cells at the six selected locations, with the same amount of economic investment. As presented in the above sections, in the calculations, the average solar insolation data,  $I_{ave}$ , are the statistical data collected by NASA on the selected geographical location during a 22-year time period (from July 1983 to June 2005) [NASA 2008]. The representative conversion efficiency of solar PV modules,  $e_m=14.79\%$ , is the average of the five efficiency values of the selected solar PV modules as mentioned above. A representative surface area is also calculated as the average of the five surface areas of the selected solar PV modules,  $A_m=1.578$



---

m<sup>2</sup>. The conversion efficiency from DC to AC power supply is taken as the typical value of 77% [NASA 2005].

As discussed in the above sections, the wind speed data for the selected geographic locations are the statistical data collected by NASA during a 10-year time period (from July 1983 to June 1993) [NASA 2005]. The selected wind turbines have an average rotor diameter of 79.73 m and a swept area of 4,992.05 m<sup>2</sup>. NASA wind speed data are collected only for 50m height above the ground. Considering the differences of wind speed at different heights above ground, in this analysis the wind speeds for each location are converted between these two different heights using equation [Simiu 1978]:

$$v_z = v_0 \left( \frac{z}{z_0} \right)^k \quad (2-2)$$

In equation (2-2), the Hellman exponent value is a key parameter. The k value depends on the location and the shape of the terrain on the ground and the stability of the air [Kaltschmitt 2007]. Since large scale manufacturing facilities such as automotive manufacturing are all located in city areas, in this analysis, the k=0.34 value is selected for the condition of neutral air above human inhibited areas [Kaltschmitt 2007].

The calculated wind speeds at hub height, as well as the calculated wind power density are presented in Table 4.9.

	Detroit	Mexico city	Sao Paulo	Shanghai	Cairo	Bochum
Wind speed at hub height (m/s)	6.58	4.39	4.68	6.56	5.58	7.78
Wind power density ( $w/m^2$ )	356.36	76.50	116.59	352.08	213.01	591.78

Table 4.9 Calculated wind speed and wind power density

The two types of stationary fuel cell power systems are dependent on continuous supply of fuels (hydrogen and natural gas, respectively) for power generations. In terms of economic cost, current hydrogen-based fuel cell power systems are much more expensive than natural-gas-based fuel cell power systems. As demonstrated in Table 4.5 above, the overnight cost of hydrogen-based fuel cell power systems is almost double of that of natural-gas-based fuel cell system, while the operating and maintenance costs are more than 400 times higher due to the high-cost processes associated with hydrogen production and storage with current technologies.

As a result, the cost benefit analysis is conducted on these clean energy supply patterns for each location using equation (3-11). The calculated cost benefit results, in terms of GHG emission reductions per \$1000 cost investment on these clean energy systems at the six selected locations are shown in Figure 4.10 below. The analysis results demonstrate that among these clean energy technologies; wind energy has the

highest cost benefit performance at all the six selected geographical locations except in Mexico City. The reason is that Mexico City has the lowest wind energy density among all these six locations, only  $76.5 \text{ W/m}^2$  based on the calculations. In comparison, the wind energy density data are  $356.4 \text{ W/m}^2$  for Detroit,  $116.6 \text{ W/m}^2$  for Sao Paulo,  $352.1 \text{ W/m}^2$  for Shanghai,  $213.0 \text{ W/m}^2$  for Cairo, and  $591.8 \text{ W/m}^2$  for Bochum, respectively.

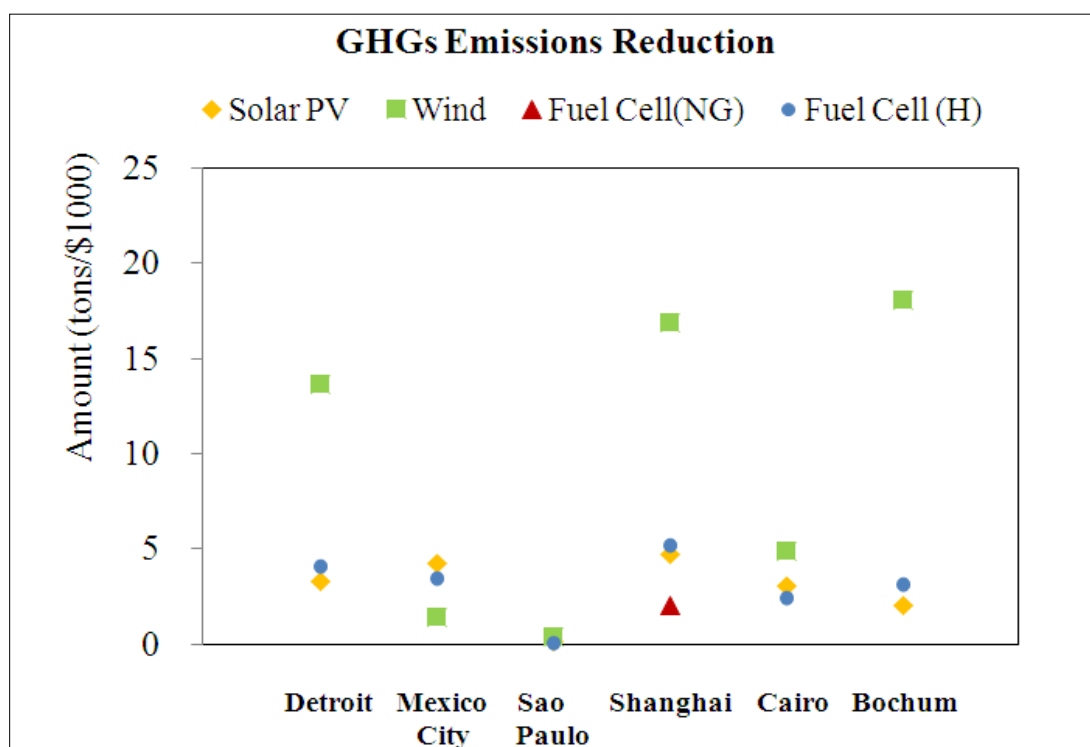

Figure 4.10 Cost benefit results of GHG mitigation through clean energy supply

As calculated on the amount of  $\text{CO}_2$  reduction per unit amount of economic investment, figure 4 shows that the high cost benefits of wind power systems are obtained at Bochum, Shanghai, and Detroit, for a reduction of GHGs at 18.04, 16.85,

---

and 13.67 tons CO<sub>2,eq</sub> per \$1000 cost. In comparison, the cost benefits of solar PV and fuel cells power systems are only between 0~5 tons CO<sub>2,eq</sub> reduction per \$1000 cost at the selected six locations with feasible application potential.

From the analysis, it is found that even though the high costs associated with current hydrogen-based fuel cell power system, it demonstrates very good cost benefit performance, only next to wind power system. In the analysis, the cost benefit performance of hydrogen-based fuel cells power system is higher than that of solar PV at Shanghai (5.18 vs. 4.7 tons/\$1000), Bochum (3.12 vs. 2.00 tons/\$1000), Detroit (4.06 vs. 3.33 tons/\$1000). This is because hydrogen fuel cell power system only generates H<sub>2</sub>O as the chemical reaction byproduct, without any CO<sub>2</sub> emission during the power generation process. While in such location as Cairo which has high solar energy intensity, solar PV has better cost benefit performance than hydrogen fuel cells power system (3.04 vs. 2.41 tons/\$1000). Based on the statistical data, Cairo has an averaged solar insolation 1929.23 kWh/m<sup>2</sup>/year [NASA 2008], which is the highest among these six selected locations.

By comparison, the natural gas fuel cell power system has the worst cost benefit performance because it consumes natural gas during its operations. All the carbons contained in the consumed natural gases are converted into CO<sub>2</sub> emissions from the fuel oxidation process. Considering the large volume of natural gas consumption (i.e., 2050 scf/hr for the selected UTC PureCell 200 model), the CO<sub>2</sub> emissions from

---

natural gas fuel cell operations are significant. In the cost benefit analysis using equation (3-11), the GHG reduction potential of natural gas fuel cell power system are negative in the selected cities except in Shanghai which means that employing the natural gas fuel cell power supply will generate more GHG emissions than current grid power supply at the selected five locations (except Shanghai), due to the higher GHG emission intensity of the natural gas fuel cell stationary power system than that of local grid power supply.

In order to support strategic decision-making, here the economic costs of using such clean energy power systems for GHG mitigation are also calculated on GM's manufacturing facilities at the selected global locations. The cost is calculated for a strategic reduction of 5%~30% of GHG emissions from GM's manufacturing facilities in the base year of 2009 which has a total amount of 6.75 million metric tons of GHG emissions [GM 2010]. The calculated results are shown in Figure 4.11 below. The analysis results demonstrate that for reducing a fixed amount of CO<sub>2</sub> emissions, the lowest cost is with wind power system in Bochum. The economic costs of wind power supply for GHG reduction in Bochum is \$18.7 million for 5% GHG reduction, \$37.4 million for 10% GHG reduction, and \$112 million for 30% GHG reduction. The economic costs of wind power supply for GHG mitigations in Shanghai and Detroit are at \$20.0 and \$24.7 million respectively for 5% GHG reduction from GM's 2009 facility emissions.

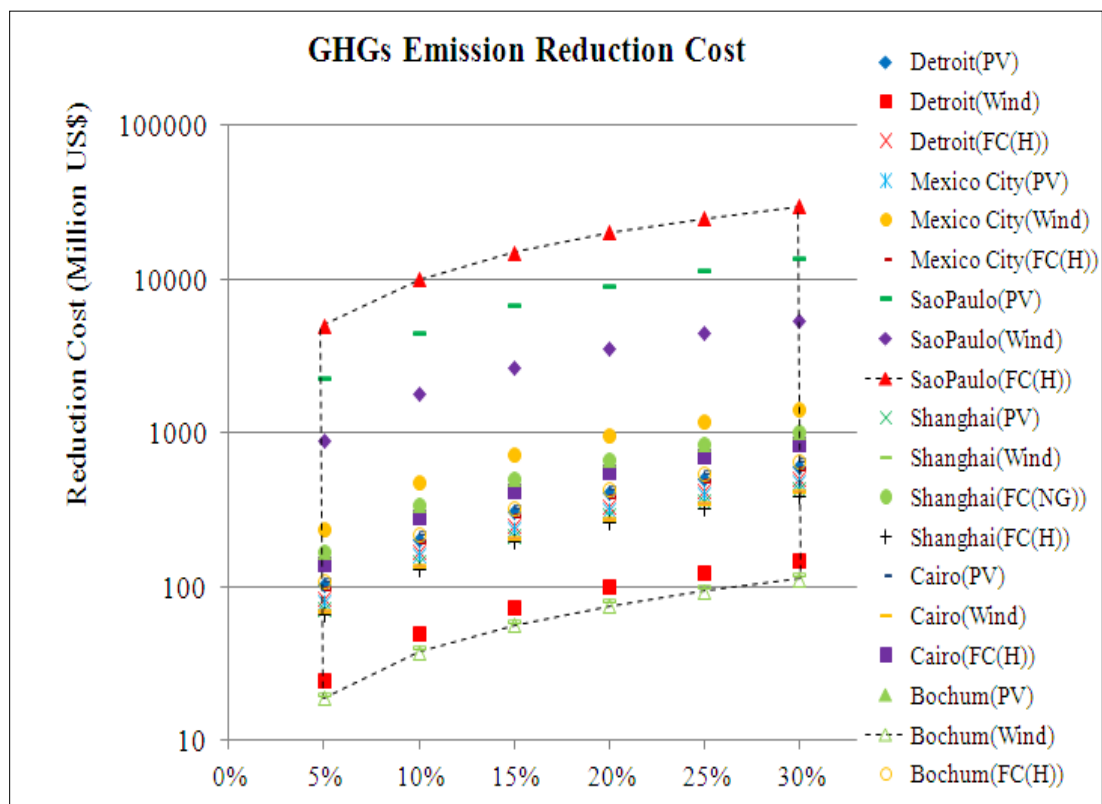

Figure 4.11 Costs of clean energy supply for reducing 5%~30% of GM's GHG emissions

The analysis results indicate that the highest cost of clean energy supply for GHG reductions is in Sao Paulo because Sao Paulo has the lowest GHG emission factor from grid power supply (only 93 g CO<sub>2eq</sub> /kWh) among the six selected locations. In the analysis, the highest cost for reducing 5% of GHGs from GM's manufacturing facilities on the base year of 2009 is obtained at \$4.96 Billion on hydrogen fuel cell power supply in Sao Paulo, which is about 265 times of the lowest cost option (\$18.7million) on wind power supply in Bochum. The second most expensive option

---

is using solar PV for GHG reduction in Sao Paulo, at a cost of \$2.25 billion for 5% GHG emission reduction from GM's 2009 facility emissions.

Overall, the economic costs of using wind power systems for reducing 5% of GHGs from GM's 2009 facility emissions range between \$18.7 million in Bochum and \$888 million in Sao Paulo, while solar PV between \$71.7 million in Shanghai and \$2.25 billion in Sao Paulo, hydrogen fuel cells between \$65.1 million in Shanghai and \$4.96 billion in Sao Paulo. Natural gas fuel cell power system is only feasible in Shanghai, with a cost of \$169 million for reducing 5% of GHGs from GM's 2009 facility emissions.

As there are technical variations among the selected clean energy power systems, the cost benefit of using a specific clean energy technology might be different from each other. In order to characterize the sensitivity and uncertainty of using a specific power system among the selected models for each clean energy technology, the range of GHG reduction, in the unit of tons/\$1,000, for the selected clean energy power systems are calculated for their applications at the six selected locations. The results are shown in Figure 4.12 below, with the median value indicated for each mitigation range.

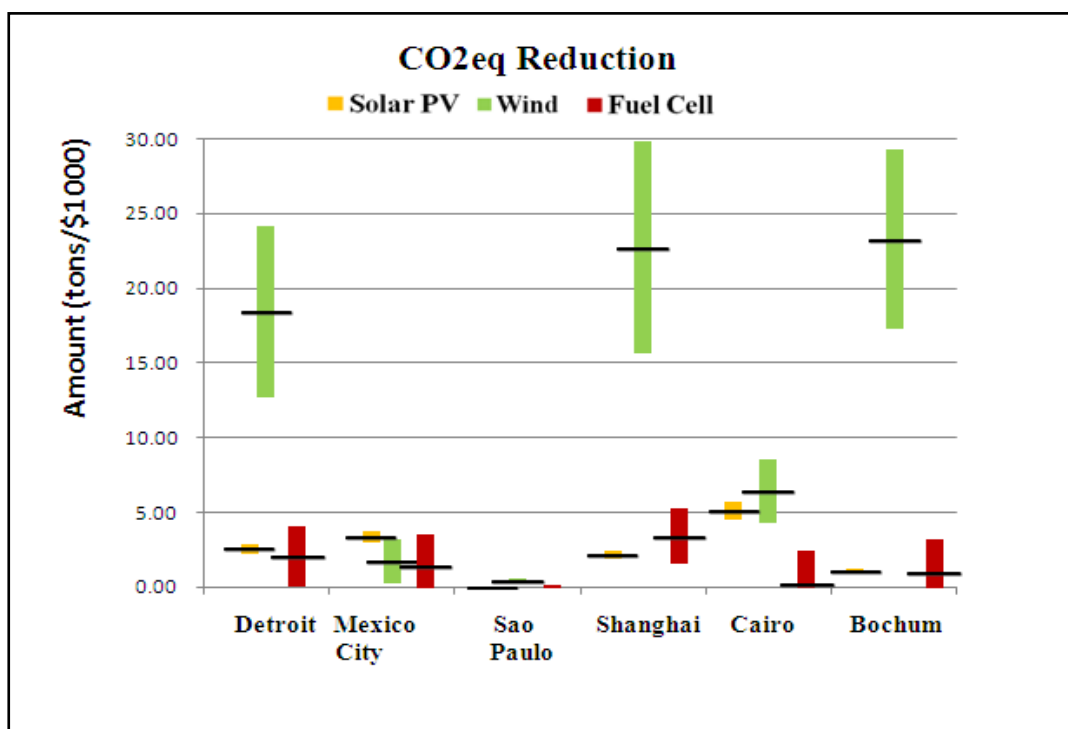

Figure 4.12 Range of GHG mitigation potential through clean energy supply at the selected six locations.

Figure 4.12 demonstrates that the selected wind power systems have the highest GHG mitigation potential among the three clean energy technologies, in particular for application in Detroit, Shanghai and Bochum. The highest GHG reduction from wind application in Shanghai can reach 30 tons per \$1,000 economic input. Wind power supply in Bochum and Detroit can achieve up to 29 tons and 24 tons of reduction, respectively, per \$1,000 economic input. As quantitatively indicated, the minimum amounts of GHG reduction from adoption of the selected wind turbines in Detroit, Shanghai and Bochum are still more than 13, 15, and 17 tons, respectively, per \$1,000



---

economic input. When compared, the application of the selected solar PV models can only reduce an amount of GHG emissions less than 6 tons per \$1,000 economic input. Fuel cell power systems are almost at the same level of GHG mitigation effect with solar PV systems. If using natural gas based fuel cell power systems, GHG mitigation is only feasible in Shanghai, China.

#### 4.7.2 Cost Benefit Range of GHG Mitigation through Clean Energy Supply at the Six Countries

The above analysis results are on applications of the selected representative clean power systems at specific geographical locations (cities). In order to understand the GHG mitigation potential of clean energy supply for broader areas, the analysis results are extended to the country-wide geographical area, and assessed for the range of GHG mitigation potential in the six countries selected for this study. The range of GHG mitigation potential are calculated for solar PV and wind power systems based on the selected average technical parameters.

The range of GHG mitigations from solar PV power supply is calculated by considering the best and worst power generation scenarios under the highest and lowest solar insolation conditions within the geographical boundary of the selected country. The range of GHG mitigation from wind power supply is calculated by considering the best and worst power generation scenarios under the highest wind

energy density of that country and the minimum wind speed (4.47 m/s) required for wind turbine installation [AWEA 2010].

The range of GHG mitigation from fuel cell power supply is calculated by considering the fuel differences of the power systems based on the technical parameters collected for the modules. The calculated range of GHG mitigation potential gives the maximum and minimum amount of GHGs which can be mitigated through each clean energy supply pattern in these six countries on the basis of the same economic input. The results are shown in Figure 4.13 below, with the median value indicated for each mitigation range.

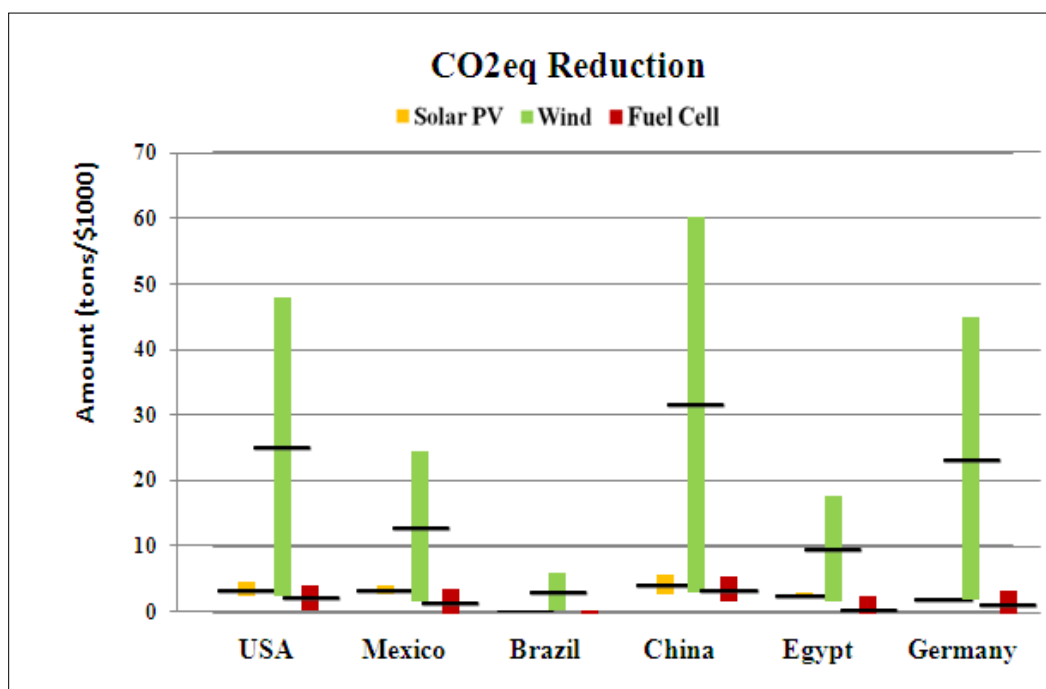

Figure 4.13 Range of GHG mitigation potential through clean energy supply in the selected six countries

---

The calculated results in Figure 4.13 demonstrate that the best GHG mitigation opportunity is in China. With \$1,000 economic investment, the maximum amount of GHG reduction can be as high as 60 tons, while application of wind power systems in the United States and Germany can also obtain a maximum GHG reduction of between 40 and 50 tons. When compared with the wind supply pattern, application of solar and fuel cell power systems has much less potential for GHG mitigation in each country. The median values of GHG mitigation range from fuel cells and wind power supply are almost at the same level.

The maximum reduction of GHG emissions through clean energy supply depends on many factors. From the results of the analysis, the most important factors for an optimal GHG mitigation are on the selection of the clean energy technology and the geographical location for system installation. In this analysis, the technical differences of the selected power systems in each clean energy category are not fully assessed and benchmarked, but such differences are believed having very small influences on the decision-making in clean energy technology selections.

#### 4.7.3 Cost Benefit Map for the Lower 48 States of U.S

The GHG reduction potential through solar PV and wind energy supply within the US nationwide is discussed in this section. The potential distribution will help the automotive manufactures comparatively understand the GHG reduction potential within

the US nationwide area, as well as to understand the dependence of the GHG reduction potential on geographic characteristics. Here the solar insolation distribution, as well as the calculated wind power density distribution is presented in Figure 4.14 and Figure 4.15, because the solar insolation and wind power density are the most factors to decide the GHG reduction potential through solar PV and wind energy, specifically.

The meteorological data are collected for each single geographical point within the 48 US lower states. Each individual geographic point is defined by its longitude and latitude. The contour plots of US nationwide GHG mitigations through solar PV and wind power supplies are generated by including the calculation result at each individual geographic point. The GHG emission reduction potential distributions through solar PV and wind for the US 48 lower states are presented in Figure 4.16 and Figure 4.17.

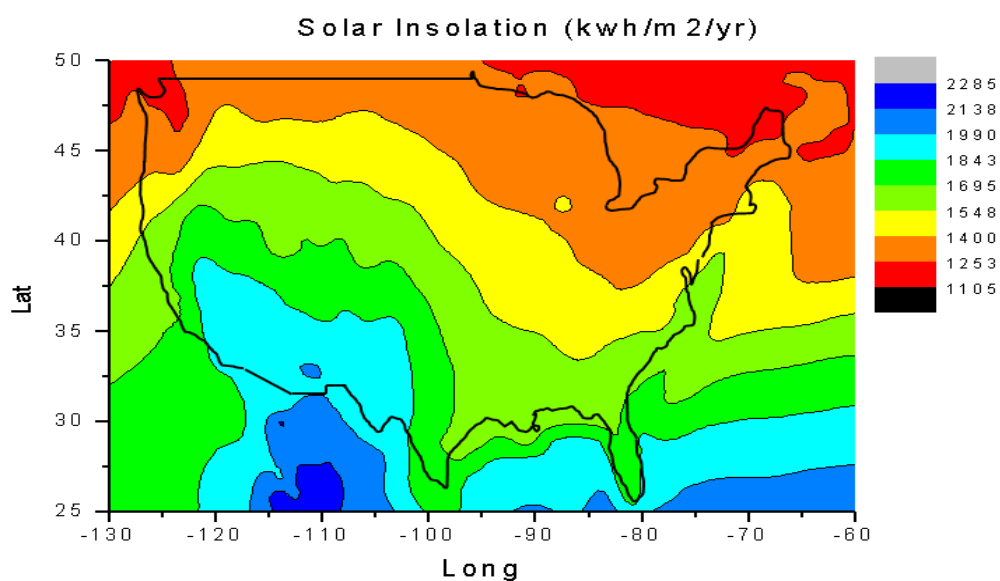

Figure 4.14 Solar insolation distributions in the US lower 48 states

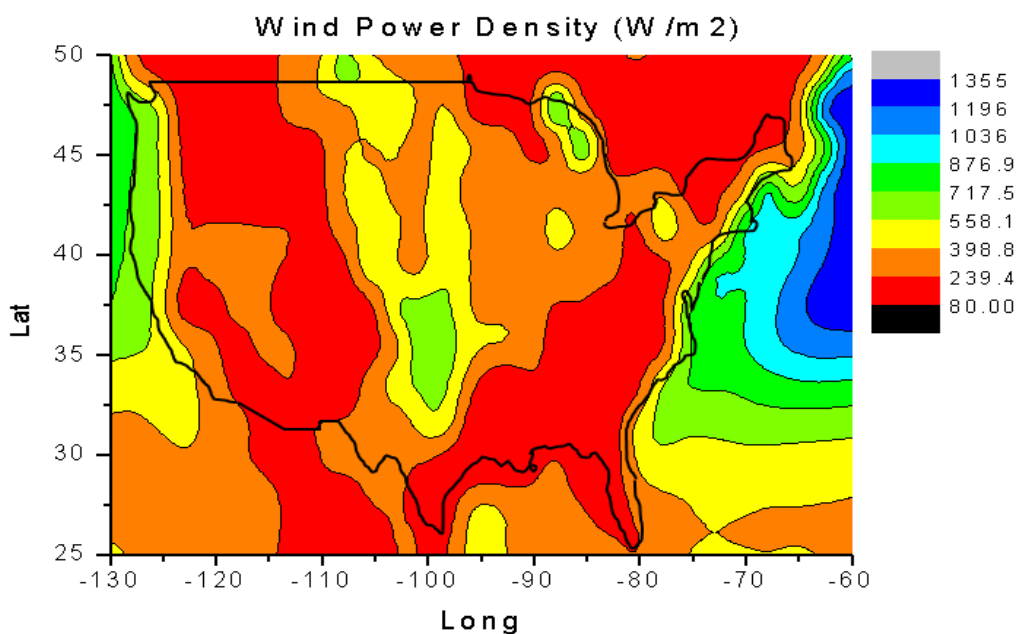

Figure 4.15 Wind power density contour plots of US lower 48 states

Figure 4-16 indicates that among the US 48 lower states, through solar PV energy supply, the GHG emission reduction potential is as high as 5.6 tons, with \$1000 economic input. Through the northeast to the southwest, the GHG emission reduction potential shows an ascending trend. This distribution pattern is roughly similar with the pattern of the solar insolation distribution pattern, which indicates that the GHG emission reduction potential through solar PV energy supply is positively associated with the local solar insolation.

Figure 4.17 demonstrates the GHG emission reduction distribution within the US 48 lower states, through wind energy supply. The calculated results indicate that the best opportunities to reduce GHG emission through wind energy supply are roughly distributed with the range from Longitude -110 to -95. Figure 4.14 shows in this range of area, the wind power densities are also higher than the rest of the geographical area.

These results indicate that the GHG emission reduction potential through wind energy supply has a positive dependence on the local wind power densities.

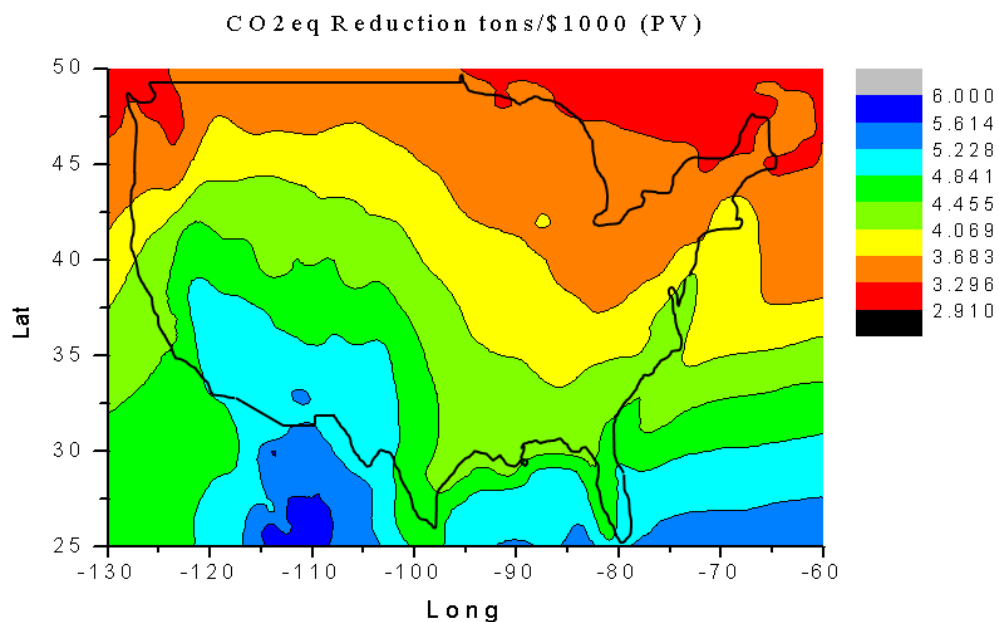

Figure 4.16 GHG emission reduction potential through PV in the US lower 48 states

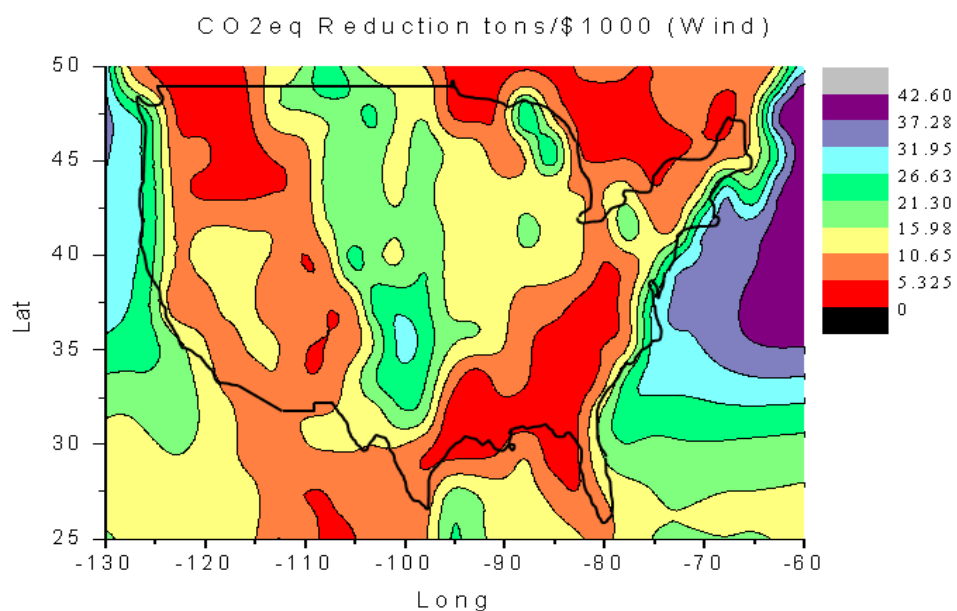

Figure 4.17 GHG emission reduction potential through wind energy in the US lower 48 states

---

#### **4.8 Trend Analysis of GHG Emission Reduction Cost Benefit from year 2010-2035**

As the clean energy supply is targeting a future deployment, a trend analysis will be useful for decision support in the strategic planning of clean energy supply for automotive and similar large-scale manufacturing facilities. Here the analysis results are presented on the future trend of cost benefits for solar PV, wind, natural gas and hydrogen-based fuel cell power systems till year 2035.

The cost benefit projections were calculated in the virtual scenario of reference case and decreasing cost case, as defined by U.S. EIA [US EIA 2011]. For the reference case, initial overnight costs for all technologies were updated to be consistent with costs estimates for 2010 [US EIA 2011]. Based on the scenario, a cost adjustment factor based on the projected producer price index for metals and metal products is also applied throughout the forecast, allowing the overnight costs to fall in the future if this index drops or rise further if the index increases [US EIA 2011]. In the decreasing cost case, base overnight costs for electric generating technologies are assumed to fall more rapidly than in the reference case. The base overnight costs are assumed to be 20 percent below the reference case, through a reduction in the annual cost index. Costs are also assumed to decline more rapidly, so that by 2035 the cost factor is assumed to be 40 percentage points below the reference case value [US EIA 2011].

---

Besides the cost benefit results shown in for year 2010, the future cost benefit trends are calculated for the year 2020 and 2035 based on the U.S. EIA cost prediction data for solar PV, wind and natural gas fuel cells [US EIA 2011], while the cost data for hydrogen fuel cell power systems in the year 2020 and 2035 are converted from the projected cost data in [Gerboni 2008].

For reference case and decreasing cost case, the calculated cost benefit trend results are shown in Figure 4.18 and Figure 4.19 respectively, for each location with different types of clean energy supply patterns. The calculated results indicate that solar PV, wind and hydrogen-based fuel cell power systems are feasible for GHG mitigations at all six selected locations, while the natural-gas-based fuel cell power system is only feasible in Shanghai, as shown in figure 4.18(d) and Figure 4.19(d).

Overall, the cost benefits of all these clean energy supply for GHG mitigation are increasing from 2010 to 2035, for both the reference case and decreasing cost case scenarios. In terms of the amount of GHG mitigation through unit economic input (tons CO<sub>2,eq</sub>/\$1000), wind technology is still the best option at five selected locations, except in Mexico City where solar PV is the best option.

For reference case scenario, in year 2020, the expected cost benefits of wind supply for GHG mitigation can reach 16.83 and 18.02 tons CO<sub>2,eq</sub>/\$1000 in Shanghai, and Bochum, respectively, while in 2035, the cost benefits can be expected to be increased



---

to 20.85 and 22.33 tons CO<sub>2,eq</sub>/\$1000, respectively. Among the six global locations, hydrogen-based fuel cell power system has better cost benefit performance than solar PV in Detroit, Shanghai and Bochum, while a little bit lower performance in Mexico City, Sao Paulo and Cairo.

For decreasing cost case scenario, in year 2020, the projected cost benefits of wind supply for GHG mitigation can reach 23.19 and 24.83 tons CO<sub>2,eq</sub>/\$1000 in Shanghai, and Bochum, respectively, while in 2035, the cost benefits can be expected to be increased to 34.63 and 37.08 tons CO<sub>2,eq</sub>/\$1000, respectively. Among all the six global locations, hydrogen-based fuel cell power system has more significant increasing rates than solar PV and wind energies.

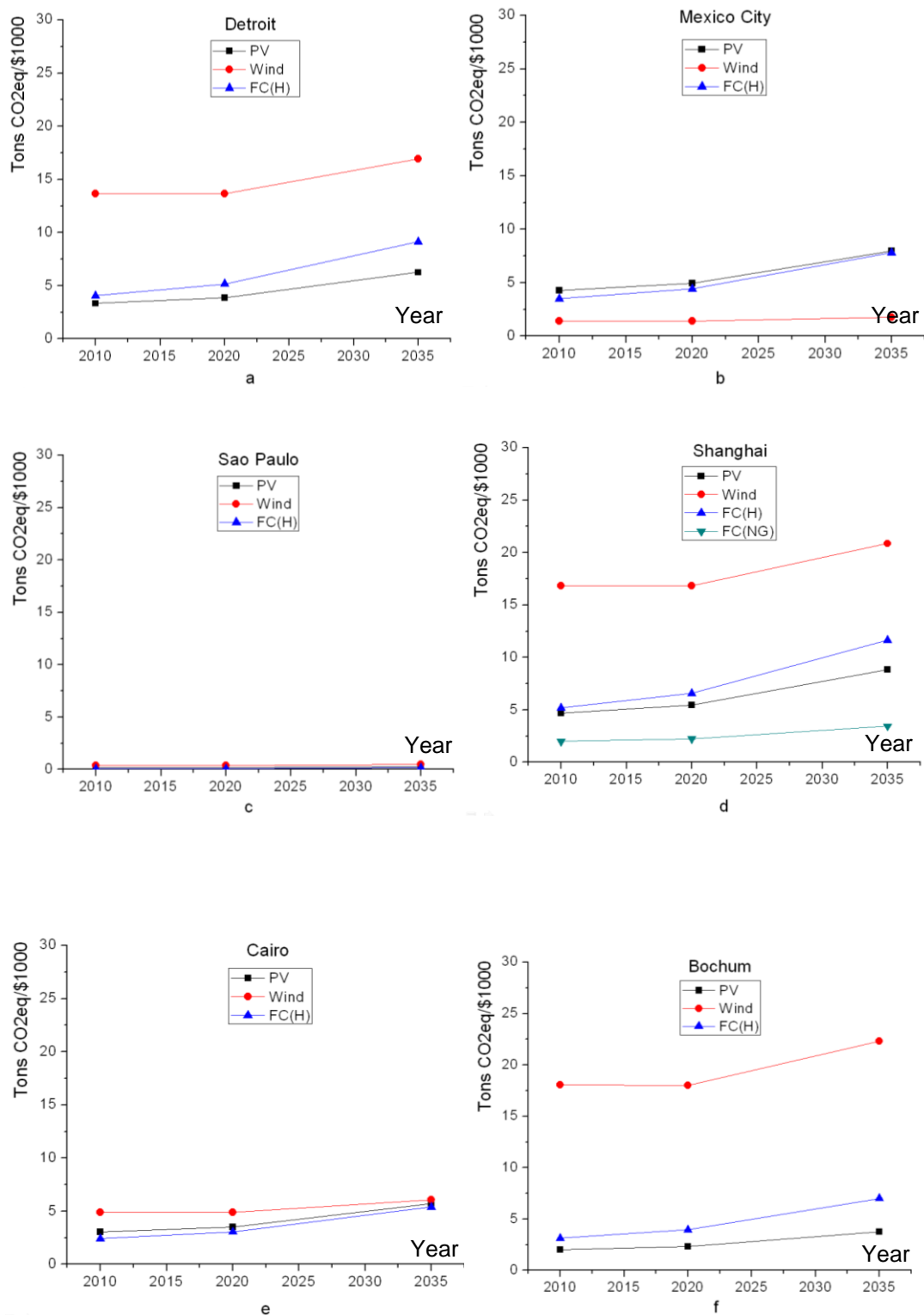

Figure 4.18 Cost benefit trend of clean energy supply for GHG mitigations from 2010-2035 (reference case)

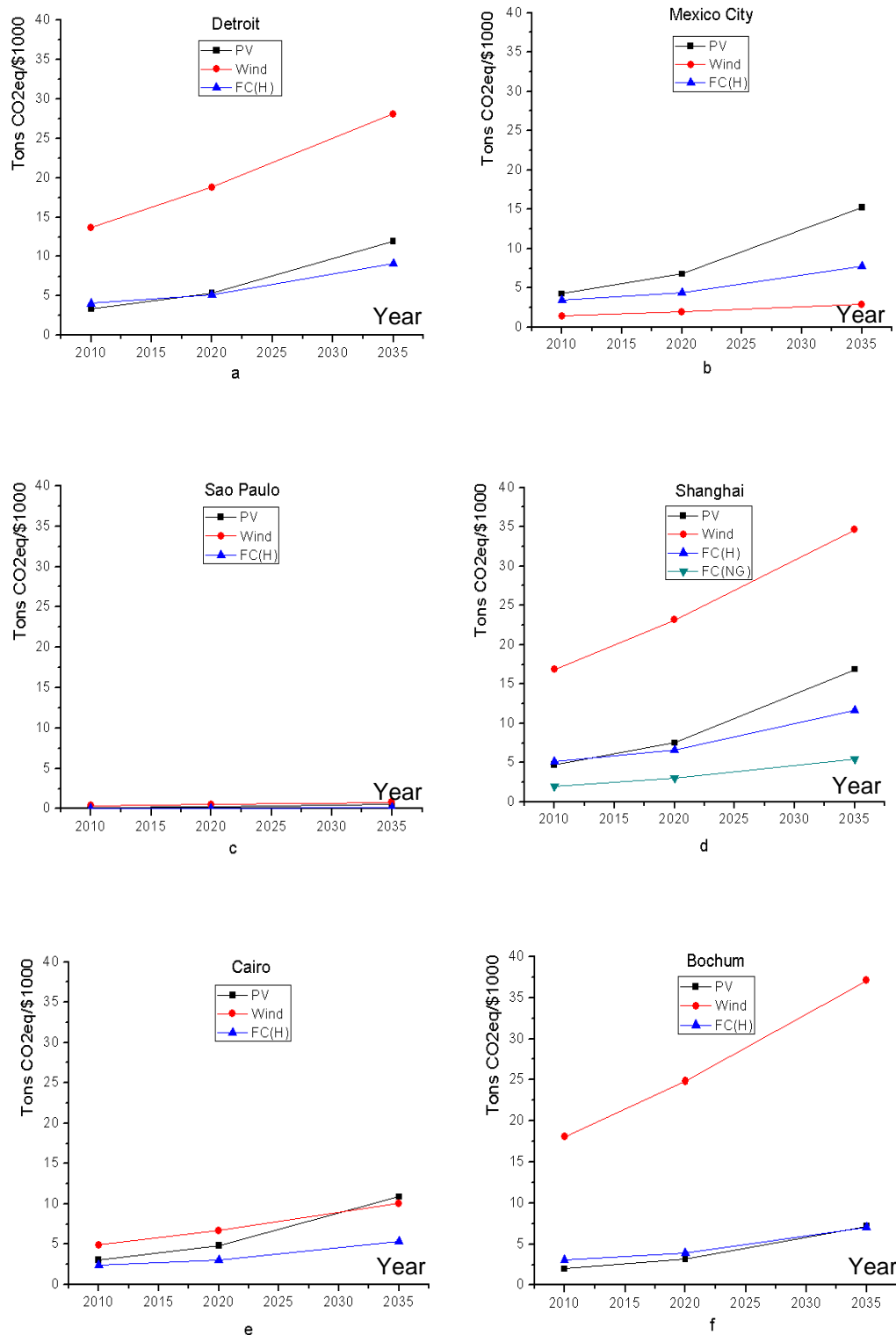

Figure 4.19 Cost benefit trend of clean energy supply for GHG mitigations from 2010-2035 (Decreasing Cost Case)

---

## 4.9 Sensitivity Analysis

As discussed in the above chapter, the mathematical methodology developed in this study involves quite a few parameters, including both meteorological and economic parameters. The importance strength is analyzed for different variables, by ordering their Pearson's correlation coefficient. This strength indicates the linearity relevance of the inputs and output, namely, the meteorological characteristics, the economic parameters and the cost benefits. The sensitivity analysis will also help with decision making by increasing understanding or quantification of the model.

The sensitivity analysis is conducted in this study by applying Pearson's correlation coefficient method with equation (3-12, 3-13). Where X stands for input variables; Y stands for output variables. The geographical sensitivity analysis is objected to help understand the relevance of the geographic parameters and the GHG emission reduction cost benefit through clean energy supplies for different geographic locations. The economic sensitivity analysis is objected to help understand the relevance of economic parameters and the GHG emission reduction cost benefits through clean energy supplies for a specific location. The calculation results of geographic sensitivity analysis for wind energy and economic sensitivity analysis for Detroit are presented in Figure 4.20 and Figure 4.21, respectively. For solar PV energy supply, since the most important geographic parameters are mainly solar insolation and local grid GHG emission factor, the relevance between inputs and outputs is less

complicated than wind energy, so the sensitivity analysis for solar PV energy is not presented here.

Figure 4.20 demonstrates that, for the GHG emission reduction cost benefit model of wind energy supply, all the observed geographic parameters are significantly determining the performance of cost benefit. The calculation results indicate wind speed and wind power density are the most two significantly linear relevant input parameters with cost benefit, with the correlation coefficient as high as above 0.9. Temperature and local GHG emission factor are also highly linear relevant with the cost benefit, with the correlation coefficients as high as 0.8 and 0.7. As a local geographic parameter, altitude is less significantly linear relevant than the other geographic parameters, with the correlation coefficient 0.6.

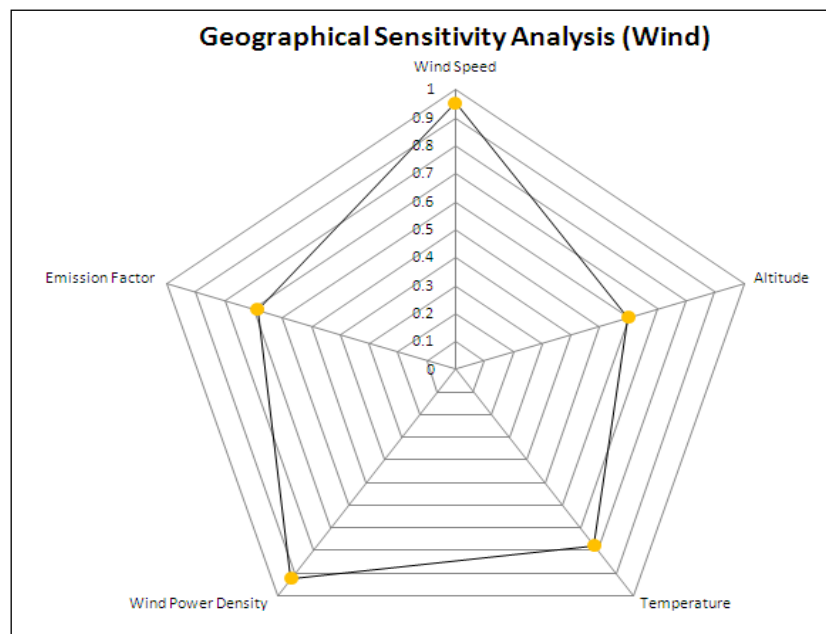

Figure 4.20 Geographic parameter sensitivity analyses

Figure 4.21 presents the linear relevance between economic parameters and GHG emission reduction cost benefits through different clean energy supplies. This analysis is objected to investigate the changes of GHG emission reduction according to the changes of clean energy technology supply. Hence, this analysis is also a sensitivity analysis for technological parameters. Figure 4.21 demonstrate that both the emission factor and the economic costs are significantly linear relevant with the cost benefits, except for the Fixed O&M. The correlation coefficients of emission factor and overnight cost are as high as 0.6. The correlation coefficient of variable O&M is also as high as above 0.5. The correlation coefficient of Fixed O&M is less than 0.2. These results demonstrate that the changes of emission factor, overnight cost and variable O&M will significantly change the output, namely the GHG emission reduction cost benefit, by using the mathematic model developed in this study.

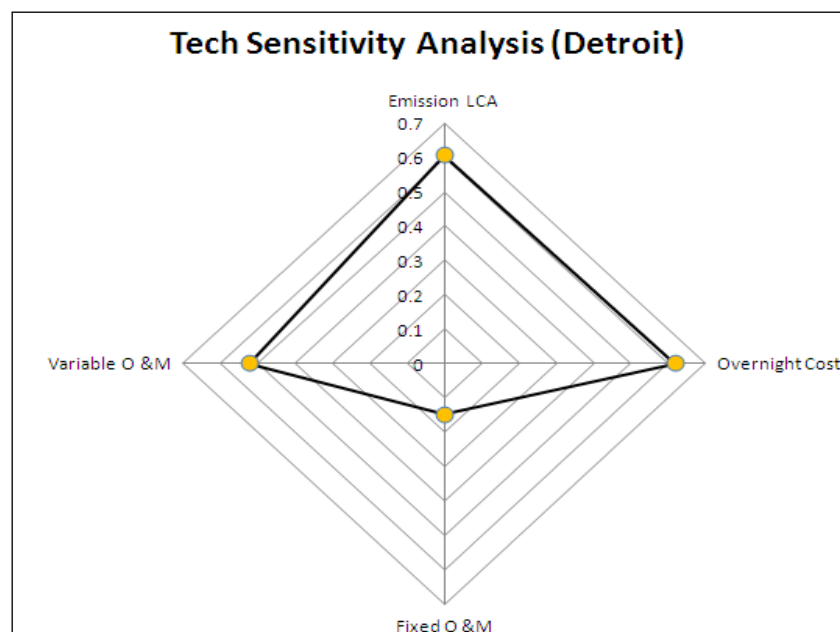

Figure 4.21 Technical parameter sensitivity analyses (Detroit)

Both the above sensitivity analyses provide guidelines for decision making by ordering the significance of the different input parameters, namely the geographic and the economic parameters.

---

## CHAPTER 5 CONCLUSIONS

GHGs emission reduction has to be appropriately conducted globally, as it drives the global warming effect continuously, more and more significantly. Manufacturing industry, as a one of the large scale GHGs emission contributors, should play a role in the global GHGs emission reduction effort. However, there is lack of neither systematic decision making supporting tools for manufacturing company's decision makers. The researched work in this dissertation is a contribution to the research on how to qualitatively and quantitatively investigate the GHGs reduction strategy from a company scale.

### 5.1 Main contributions to knowledge

A systematic mathematic approach is successfully developed to qualitatively and quantitatively investigate the application potential of solar PV, wind and Fuel cells technologies in GHGs emission reduction. This systematic approach contains a set of mathematic analyses including the analyses of technological feasibility, capacity factor, Feed- in strength, Levelized Energy Cost, cost benefit and sensitivity. In this approach, both the clean energy's technological characteristics and the geographical conditions where this clean technology could be potentially implemented are included into the analysis process.



---

This systematic approach is successfully applied for the application potential analysis of solar PV, wind and fuel cells at six global locations, including Detroit, Mexico City, Cairo, Shanghai, Sao Paulo and Bochum. The application potentials of solar PV, wind and fuel cells are successfully investigated at the six selected global locations. The systematic approach is successfully applied for the cost benefit range analysis of solar PV, wind and fuel cells in the six selected countrywide area. The main findings through the case study are summarized as follows:

1). Solar PV, wind, and hydrogen-based fuel cell technologies all have certain potentials for practical applications as clean energy supply for GHG mitigations at all these six locations, while the natural gas-based fuel cell power system is only technically feasible in Shanghai (China) because of the high local GHG emission factor from the conventional grid. Among all these six locations, wind energy has the highest potential in terms of absolute amount of GHG mitigation when compared with the other clean power systems.

2). For the selected solar PV power systems, the actual capacity factors are all below 20% at these six selected locations; while the capacity factor of wind can reach up to 47% at these locations. Cairo has the largest capacity factor for solar PV at 17.98%, followed by Mexico City (17.62%) and Sao Paulo (15.48%). The capacity factors for solar PV in Shanghai, Detroit and Bochum are 13.15%, 11.84% and 9.19%, respectively.

---

3). A case study on FIT strength benchmarking among seven countries including United States, Germany, South Africa, China, Italy, Iran, and South Korea is quantitatively conducted. According to the analysis, for solar PV, Iran has the highest FIT strength in terms of the GHGs emission reduction on the same economic incentive base among the selected seven countries. For wind energy, China and South Africa are the two countries which have the highest mitigation benefits on the same amount of economic incentive input.

4). LEC calculation is successfully conducted for solar PV, wind and fuel cells in the six selected locations. For solar PV, it has the smallest LEC in Cairo (16.29 cents/kWh). The LEC is the minimum required price for the electricity to be retailed, therefore the smaller the LEC, the larger the application potential. For wind energy, Mexico City has the largest LEC and Bochum has the smallest one. In this regard, Cairo has the largest economic application potential of solar PV and Bochum has the best economic application potential of wind energy.

5). The systematic approach is successfully applied for the cost benefit analysis of solar PV, wind and fuel cells at the six selected global locations. The cost benefits of the different location and technology combinations are successfully calculated and compared. The mathematic cost benefit analysis approach is applied for the cost benefit range analysis within the nationwide range of the six selected countries. By using this method, cost benefit maps for the US 48 down states area are plotted based

---

on the calculation results. This mathematic model is also successfully applied for the cost benefit trend analysis from 2010-2035.

6). As a part of this systematic approach, the sensitivity analysis is successfully conducted for the cost benefit model. The linear relevance of different key geographic parameters, as well as technological parameters with the cost benefit is successfully calculated. The linear relevance of these parameters with the cost benefit is successfully used in revealing the priority in considering the selection of a specific clean technology at a specific location for GHG emission reduction application.

The researched work in this dissertation concludes with the following suggestions, should a decision be made on the selection of clean energy technologies for GHGs emission reduction:

## **5.2 Suggestions for practical applications**

First, at the beginning of the GHGs emission reduction goal set up, a comprehensive GHGs inventory analysis should be conducted. Through this inventory analysis, the GHGs emission sub-sources within the complete product life cycle should be clearly outlined and listed. With this inventory analysis as a reference, the GHGs emission reduction potential should be defined within in the feasible stage of the product life cycle.

Second, the application potential of clean energy technologies should be comprehensively investigated; both the specificity of technological characteristics and the geographic varieties should be involved into the application potential verification.

Third, GHGs emission reduction is such a long term project for a manufacturing company that a long term performance projection analysis should be conducted before the practical application project is set up at a specific location.

Finally, a sensitivity analysis for all the involved input parameters, including geographic and technological parameters should be conducted, so as to find out the priorities of different parameters to be considered.

### **5.3 Future research directions**

Through the researched dissertation work, a systematic mathematic approach is developed to quantitatively analyze the application potential of solar PV, wind and fuel cells in reducing GHGs emissions. In practice, in order to improve the application range and its scientific merits, the following research focuses are presented.

#### **5.3.1 Development of the GHGs emissions related database**

Through this researched work, a wide range of data has been used; there data are collected from a few kinds of sources, including publications, released governmental documentations, online database, etc. A comprehensive database of the available useful data, including statistic historic data, projection data, and analyzed results will be of great support for the researchers. This database should be updated promptly with the availability of new data release.

### 5.3.2 The research and development of cost benefit analysis tools

A systematic approach is developed for the application potential analysis. The mathematic principles and key element of this systematic method is presented in this research. During the conduction of the case study, a large amount of calculation work is performed, which is a huge consumption of time. For example, the calculation of the cost benefit map of US 48 down states is very time-consuming due to the large number of data. Different aspect of this systematic approach needs different calculation method and involves repeating data input, which is also not time economic. In the future, all the aspects of the developed mathematic method can be integrated into specific tools, such as software. All the useful data could be read from the database discussed in the above section, which will save the researchers a huge amount of time. The interested indicator, such as FIT strength, cost benefit will be calculated within the software and output.

---

## REFERENCES

American Wind Energy Association (AWEA) (2010), <http://www.awea.org/faq/rsdntqa.html>. Accessed on 09/13/2010.

Azapagic, A. (2002). Life Cycle Assessment: A Tool for Identification of More Sustainable Products and Processes, p62-85. In: Handbook of Green Chemistry and Technology (Clark, J. and D. Macquarrie, eds.), Blackwell Science, Oxford.

Azzopardi B, Mutale J, (2010). "Life cycle analysis for future photovoltaic systems using hybrid solar cells", Renewable and Sustainable Energy Reviews, 14, 1130–1134.

BP, BP Statistical Review of World Energy. (2012). [http://www.bp.com/assets/bp\\_internet/globalbp/globalbp\\_uk\\_english/reports\\_and\\_publications/statistical\\_energy\\_review\\_2011/STAGING/local\\_assets/pdf/statistical\\_review\\_of\\_world\\_energy\\_full\\_report\\_2012.pdf](http://www.bp.com/assets/bp_internet/globalbp/globalbp_uk_english/reports_and_publications/statistical_energy_review_2011/STAGING/local_assets/pdf/statistical_review_of_world_energy_full_report_2012.pdf), accessed on 11/10/2012

Chang TJ, Wu YT, Hsu HY, Chu CR and Liao CM (2003), Assessment of wind characteristics and wind turbine characteristics in Taiwan. Renew Energy 28, 851–871.

Cory, K.; Couture, T., and Kreycik, C. (2009) "Feed-in Tariff Policy: Design, Implementation, and RPS Policy Interactions." National Research Energy Laboratory, Rep. NREL/TP-6A2-45549, March 2009.

Daimler environmental data absolute, <http://sustainability.daimler.com/reports/daimler/annual/2010/nb/English/7030/environmental-data-absolute.html> accessed on 11/01/2010

Darling S, You F, Veselka T and Velosa A, Assumptions and the levelized cost of energy for photovoltaics, Energy & Environmental Science, DOI: 10.1039/c0ee00698j, <http://www.renewableenergyworld.com/assets/documents/2011/LCOE-SolarPaper.pdf>, accessed on Apr.14, 2012.

---

Eduardo Martínez & Félix Sanz & Stefano Pellegrini, Life-cycle assessment of a 2-MW rated power wind turbine: CML method. *Int J Life Cycle Assess* (2009) 14:52–63

Ford 2006/07 sustainability report, [http://www.ford.com/doc/2006-07\\_sustainability\\_report.pdf](http://www.ford.com/doc/2006-07_sustainability_report.pdf), accessed on 11/01/2010

Ford 2007/08 sustainability report, <http://www.ford.com/doc/sr07-ford-sustainability.pdf>, accessed on 11/01/2010

Ford 2008/09 sustainability report, <http://www.ford.com/doc/sr08-blueprint-summary.pdf>, accessed on 11/01/2010

Forster, P., V. Ramaswamy, P. Artaxo, T. Berntsen, R. Betts, D.W. Fahey, J. Haywood, J. Lean, D.C. Lowe, G. Myhre, J. Nganga, R. Prinn, G. Raga, M. Schulz and R. Van Dorland. 2007, "Changes in Atmospheric Constituents and in Radiative Forcing. In: *Climate Change 2007: The Physical Science Basis. Contribution of Working Group I to the Fourth Assessment Report of the Intergovernmental Panel on Climate Change* [Solomon, S., D. Qin, M. Manning, Z. Chen, M. Marquis, K.B. Averyt, M. Tignor and H.L. Miller (eds.)]. Cambridge University Press, Cambridge, United Kingdom and New York, NY, USA."

Fthenakis, V. M., Kim, H. C., & Alsema, E. (2008). Emissions from photovoltaic life cycles. *Environmental Science & Technology*, 42(6), 2168-2174.

General Motors Company (2010) Environmental Commitment, <http://www.gm.com/corporate/responsibility/environment/facilities/index.jsp>, accessed on 11/02/2010

General Motors Company (2010) General Motors: About GM 2010. Available online: <http://www.gm.com/corporate/about/> (accessed on 12 October 2010).

General Motors Company. Public Policy Center Environment and Energy; Voluntary Reporting of General Motors Corporation United States Greenhouse Gas (GHG) Emissions for Calendar Year (1990–2007), (2008). Available online: [http://www.gm.com/corporate/responsibility/environment/reports/greenhouse\\_gas\\_emissions/ghgreport\\_2007.pdf](http://www.gm.com/corporate/responsibility/environment/reports/greenhouse_gas_emissions/ghgreport_2007.pdf) (accessed on 5 October 2010).

---

Gerboni, R.; Pehnt, M.; Viebahn, P.; Lavagno, E. Final Report on Technical Data, Costs and Life Cycle Inventories of Fuel Cells. New Energy Externalities Developments for Sustainability (NEEDS); NEEDS Project: Rome, Italy, (2008). Available online: <http://www.needs-project.org/RS1a/RS1a%20D9.2%20Final%20report%20on%20fuel%20cells.pdf> (accessed on 15 September 2011).

Gipe P. "Renewable Energy Tariffs in Europe and Elsewhere", (2010), Available: <http://www.wind-works.org/FeedLaws/RenewableTariffs.xls>

Haas R, Faber T, Green J, Gual M, Huber C, Resch G, Ruijgrok W, and Twidell J (2001): Promotion Strategies for Electricity from Renewable Energy Sources in EU Countries, Institute of Energy Economics, Vienna University of Technology, Austria.

Hines, M. A., Chabal, Y. J., Harris, T. D., & Harris, A. L. (1994). Measuring the structure of etched silicon surfaces with Raman spectroscopy. *The Journal of chemical physics*, 101, 8055.

Honda environmental annual report 2008, [http://world.honda.com/environment/report/pdf/2008\\_report\\_E\\_full.pdf](http://world.honda.com/environment/report/pdf/2008_report_E_full.pdf), accessed on 11/01/2010

Honda environmental annual report 2009, [http://world.honda.com/environment/report/pdf/2009\\_report\\_E\\_full.pdf](http://world.honda.com/environment/report/pdf/2009_report_E_full.pdf), accessed on 11/01/2010

Huber C., Faber T, Haas R, and Resch G (2001): Promoting Renewables: Feed-In Tariffs or Certificates, IEW 2001, Institute of Power Systems and Energy Economics, Vienna University of Technology, Vienna.

Hyundai, The road to sustainability, hyundai motor company 2009 sustainability report, [http://worldwide.hyundai.com/web/C\\_Sustainability\\_down/2009\\_report.pdf](http://worldwide.hyundai.com/web/C_Sustainability_down/2009_report.pdf), accessed on 11/01/2010

Hyundai, The road to sustainability, hyundai motor company 2010 sustainability report, [http://worldwide.hyundai.com/Web/C\\_Sustainability\\_down/2010\\_reports.pdf](http://worldwide.hyundai.com/Web/C_Sustainability_down/2010_reports.pdf), accessed on 11/01/2010



---

IEA, (2006), World Energy Outlook, [www.worldenergyoutlook.org/media/weowebsite/.../WEO2006.pdf](http://www.worldenergyoutlook.org/media/weowebsite/.../WEO2006.pdf), accessed on 10/10/2012

International Energy Agency (IEA), (2001), 2011 Key World Energy Statistics, <http://www.iea.org> accessed on 11/05/2012

IPCC (Intergovernmental Panel on Climate Change). (2001). "Climate Change 2001: The Scientific Basis". IPCC Third Assessment Report. [http://www.grida.no/publications/other/ipcc\\_tar/?src=/climate/ipcc\\_tar/wg1/index.htm](http://www.grida.no/publications/other/ipcc_tar/?src=/climate/ipcc_tar/wg1/index.htm). Accessed on 10/08/09.

IPCC (the Intergovernmental Panel on Climate Change), IPCC Fourth Assessment Report (AR4) by Working Group 1 (WG1) (2007). <http://www.ipcc.ch/pdf/assessment-report/ar4/wg1/ar4-wg1-chapter2.pdf>. Accessed on 9/10/2010.

IPCC, (1990), "Climate Change: The Intergovernmental Panel on Climate Change Scientific Assessment [Houghton, J.T., G.J. Jenkins, and J.J.Ephraums (eds.)]". Cambridge University Press, Cambridge, United Kingdom and New York, NY, USA, pp.364

IPCC. "Climate Change (2007): Synthesis Report." Available: [http://www.ipcc.ch/pdf/assessment-report/ar4/syr/ar4\\_syr.pdf](http://www.ipcc.ch/pdf/assessment-report/ar4/syr/ar4_syr.pdf)

IPCC. (2005), "Special Report on Safeguarding the Ozone Layer and the Global Climate System: Issues Related to Hydrofluorocarbons and Perfluorocarbons [Metz, B., et al. (eds.)]". Cambridge University Press, Cambridge, United Kingdom and New York, NY, USA, pp.488.

ISO 14040 (2006): Environmental management – Life cycle assessment – Principles and framework, International Organisation for Standardisation (ISO), Geneva

ISO 14040:1997, Environmental Management – Life Cycle Assessment – Principles and Framework.

ISO 14044 (2006): Environmental management – Life cycle assessment – Requirements and guidelines, International Organisation for Standardisation (ISO), Geneva

---

Jaap, V.; Rooijen, A. (2006) Life Cycle Assessment of the PureCell™ Stationary Fuel Cell System: Providing a Guide for Environmental Improvement. M.Sc. Thesis, Delft University of Technology, Delft, The Netherlands.

Jungbluth N, Bauer C, Dones R and Frischknecht R, (2005) Life Cycle Assessment for Emerging Technologies: Case Studies for Photovoltaic and Wind Power, *Int J LCA* 10 (1) 24 – 34.

Kaltschmitt M, Streicher W, Wiese A (2007) Renewable energy: technology, economics, and environment. Springer, New York, page 55.

Keoleian, G. A., & Lewis, G. M. D. (1997). Application of life-cycle energy analysis to photovoltaic module design.

Loy D., Fütterer H., Jüttemann W. and Reiche D., (2004). Energy-policy Framework Conditions for Electricity Markets and Renewable Energies, Deutsche Gesellschaft für Technische Zusammenarbeit (GTZ) GmbH.

Maclean H, Lave L (1998) A Life-Cycle Model of an Automobile. *Environmental Policy Analysis* 3(7), 322A- 330A.

Mart ínez E, Sanz F and Pellegrini S, (2009) Life-cycle assessment of a 2-MW rated power wind turbine: CML method. *Int J Life Cycle Assess*, Vol. 14, pp.52–63.

Meijer A, Huijbregts M, Schermer J and Reijnders L, (2003) Life-cycle Assessment of Photovoltaic Modules: Comparison of mc-Si, InGaP and InGaP/mc-Si Solar Modules, *PROGRESS IN PHOTOVOLTAICS: RESEARCH AND APPLICATIONS*, *Prog. Photovolt: Res. Appl.* 11:275–287 (DOI: 10.1002/pp.489)

Monthorst P, “Policy Instruments for Regulating the Development of Wind Power in a Liberated Electricity Market”, in: G. Larsen, K. Westermann, and P. Noergaard, eds. (1999), *Contributions from the Department of Wind Energy and Atmospheric Physics to EWEC '99 in Nice France*, Riso National Laboratory, Roskilde, Denmark, pp. 7-12, 1999.

MWPS (My Wind Power System), “The 10 major Wind Power Companies in the World”, <http://www.mywindpowersystem.com/2009/04/the-10-major-wind-power-companies-in-the-world/>, accessed on 10/23/2010

---

NASA (2008). Atmospheric Science Data Center, Surface meteorology and Solar Energy, A renewable energy resource web site (release 6.0), accessed on 10/12/2010: <http://eosweb.larc.nasa.gov/cgi-bin/sse/sse.cgi?na+s01+s06#s01>

NASA Atmospheric Science Data Center (2005) Surface meteorology and Solar Energy, A renewable energy resource web site (Release 5 Data Set), [http://eosweb.larc.nasa.gov/sse/global/text/10yr\\_wspd50m](http://eosweb.larc.nasa.gov/sse/global/text/10yr_wspd50m). Accessed on 10/12/2010.

NOAA (National Oceanic & Atmospheric Administration), (2011), Trends in Atmospheric Carbon Dioxide, <http://www.esrl.noaa.gov/gmd/ccgg/trends/>, accessed on 11/10/2012.

Oztopal A, Sahin AD, Akgun N, Sen Z. (2000) On the regional wind energy potential of Turkey. *Energy* 25:189–200.

Palz, W., & Zibetta, H. (1991). Energy pay-back time of photovoltaic modules. *International Journal of Solar Energy*, 10(3-4), 211-216.

Pannell, D.J. (1997), Sensitivity analysis of normative economic models: Theoretical framework and practical strategies, *Agricultural Economics* 16: 139-152.[1], <http://dpannell.fnas.uwa.edu.au/dpap971f.htm>

Pehnt M, (2006), “Dynamic life cycle assessment (LCA) of renewable energy technologies”, *Renewable Energy*, 31, 55–71.

REN21 (2009) Renewables Global Status Report, [http://www.ren21.net/pdf/RE\\_GSR\\_2009\\_Update.pdf](http://www.ren21.net/pdf/RE_GSR_2009_Update.pdf). Accessed on 10/4/2010.

Renewable Energy Tops 10% of U.S. Energy Production, See: <http://www.renewableenergyworld.com/rea/news/article/2008/09/renewable-energy-tops-10-of-u-s-energy-production-53684>

Renewable Energy World, “Top 10: Ten Largest Solar PV Companies”, <http://www.renewableenergyworld.com/rea/blog/post/2010/06/top-10-ten-largest-solar-pv-companies>, accessed on 10/23/2010

Rickerson W, Bennhold F & Bradbury J, Feed-in Tariffs and Renewable Energy in the USA -A Policy Update 2-3 (2008), available: [http://www.boell.org/Pubs\\_read.cfm?read=169](http://www.boell.org/Pubs_read.cfm?read=169).

---

Rodgers J and Nicewander W. (1988) Thirteen ways to look at the correlation coefficient. *The American Statistician*, 42(1):59–66.

Rooijen JV (2006) A Life Cycle Assessment of the PureCell™ Stationary Fuel Cell System: Providing a Guide for Environmental Improvement. [http://www.leidenuniv.nl/cml/ssp/students/jaap\\_van\\_rooije\\_n/lca\\_fuel\\_cell.pdf](http://www.leidenuniv.nl/cml/ssp/students/jaap_van_rooije_n/lca_fuel_cell.pdf). accessed on 10/13/2010.

Saltelli, A., Ratto, M., Andres, T., Campolongo, F., Cariboni, J., Gatelli, D. Saisana, M., and Tarantola, S, (2008), *Global Sensitivity Analysis, The Primer*, John Wiley & Sons.

Setterwall C, Münter M, Sarközi P, Bodlund, B (2004). *Methodological Guidelines. Final report. ECLIPSE: 2004.* [http://www.eclipse-eu.org/pubres\\_guide.html](http://www.eclipse-eu.org/pubres_guide.html). Accessed on 10/4/2010.

Sherwani AF, Usmani JA, Varun (2010) Life Cycle assessment of solar PV based electricity generation systems: A review. *Renewable and Sustainable Energy Reviews* 14, 540-544.

Simiu, E., and Scanlan, R. H. (1978): *Wind Effects on Structures*, Wiley (New York), Page 47.

Sims R, (2004) Renewable energy: a response to climate change, *Solar Energy* 76: 9–17

Sims R., Schock R, Adegbululge A, Fenhann J, Konstantinaviciute I, Moomaw W., Nimir H, Schlamadinger B, Torres-Martínez J, Turner C, Uchiyama Y, Vuori S, Wamukonya Zhang N, (2007): Energy supply. In *Climate Change 2007: Mitigation. Contribution of Working Group III to the Fourth Assessment Report of the Intergovernmental Panel on Climate Change* [B. Metz, O.R. Davidson, P.R. Bosch, R. Dave, L.A. Meyer (eds)], Cambridge University Press, Cambridge, United Kingdom and New York, NY, USA.

SouthAfrica.info., “South Africa's energy supply”, (2011), <http://www.southafrica.info/business/economy/infrastructure/energy.htm>

Stigler, Stephen M. (1989). "Francis Galton's Account of the Invention of Correlation". *Statistical Science* 4 (2): 73–79, doi:10.1214/ss/1177012580, JSTOR 2245329

---

Toyota, Toyota sustainability report 2008,  
[http://www.toyota.co.jp/en/csr/report/08/download/pdf/sustainability\\_report08.pdf](http://www.toyota.co.jp/en/csr/report/08/download/pdf/sustainability_report08.pdf),  
accessed on 11/01/2010

Toyota, Toyota sustainability report 2009,  
[http://www.toyota.co.jp/en/csr/report/09/download/pdf/sustainability\\_report09.pdf](http://www.toyota.co.jp/en/csr/report/09/download/pdf/sustainability_report09.pdf),  
accessed on 11/01/2010

Toyota, Toyota sustainability report 2010,  
[http://www.toyota.co.jp/en/csr/report/10/download/pdf/sustainability\\_report10.pdf](http://www.toyota.co.jp/en/csr/report/10/download/pdf/sustainability_report10.pdf),  
accessed on 11/01/2010

US (GCRP) Global Change Research Program, (2008), Energy Supply and Use,  
<http://downloads.globalchange.gov/usimpacts/pdfs/energy.pdf>, accessed on  
11/10/2012

US DOE (Department of Energy), (2007), Climate vision progress report 2007,  
[http://www.doe.gov/media/Climate\\_Vision\\_Progress\\_Report.pdf](http://www.doe.gov/media/Climate_Vision_Progress_Report.pdf), Accessed on  
10/2/2010.

US DOE (Department of Energy), “Energy efficiency and renewable energy,”  
[http://www1.eere.energy.gov/solar/solar\\_glossary.html](http://www1.eere.energy.gov/solar/solar_glossary.html)

US DOE (Department of Energy), Climate Vision Progress Report 2007. (2007)  
Available online: [http://www.doe.gov/media/Climate\\_Vision\\_Progress\\_Report.pdf](http://www.doe.gov/media/Climate_Vision_Progress_Report.pdf)  
(accessed on 2 October 2010).

US DOE (Department of Energy) (2004), Fuel Cell Handbook (Seventh Edition).

US DOE, International energy outlook 2009,  
<http://www.eia.doe.gov/oiaf/ieo/index.html>.

US EIA (Energy Information Administration) (2007), International Electricity  
Emission Factors by Country, 1999-2002.  
[http://www.eia.doe.gov/oiaf/1605/excel/electricity\\_factors\\_99-02country.xls](http://www.eia.doe.gov/oiaf/1605/excel/electricity_factors_99-02country.xls).  
Accessed on 9/10/2010.

US EIA (Energy Information Administration) (2009), Assumption to the annual  
energy outlook 2009 with project to 2030,

---

[http://www.eia.doe.gov/oiaf/aeo/assumption/pdf/0554\(2009\).pdf.pdf](http://www.eia.doe.gov/oiaf/aeo/assumption/pdf/0554(2009).pdf.pdf), Accessed on 9/10/2010.

US EIA (Energy Information Administration) (2010) Cost and Performance Characteristics of New Central Station Electricity Generating Technologies. <http://www.eia.doe.gov/oiaf/aeo/excel/aeo2010%20tab8%202.xls>, Accessed on 9/12/2010.

US EIA (Energy Information Administration) (2010), Electricity Market Module. <http://www.eia.doe.gov/oiaf/aeo/assumption/pdf/electricity.pdf>. Accessed on 3/23/2011.

US EIA (Energy Information Administration), (2011), “Assumptions to the Annual Energy Outlook 2011”, <http://205.254.135.7/forecasts/aeo/assumptions/pdf/0554%282011%29.pdf>. Accessed on 12/12/2011.

US EIA (Energy Information Administration), 2003 and 2004. <http://www.eia.doe.gov/iea/>

US EIA (Energy Information Administration), based on data from the following sources: International Energy Agency (IEA), Electricity Information Database 2007 and CO2 Emissions from Fuel Combustion Database 2006, <http://www.iea.org>, October 2007.

US EIA (Energy Information Administration), Cost and Performance Characteristics of New Central Station Electricity Generating Technologies, (2010), Available online: <http://www.eia.doe.gov/oiaf/aeo/excel/aeo2010%20tab8%202.xls> (accessed on 12 September 2010).

US EIA (Energy Information Administration), Domestic Electricity Emission Factors, 1999–2002; EIA: Washington, DC, USA, (2007). Available online: [http://www.eia.doe.gov/oiaf/1605/excel/electricity\\_factors\\_99-02region.xls](http://www.eia.doe.gov/oiaf/1605/excel/electricity_factors_99-02region.xls) (accessed on 10 September 2010).

US EIA (Energy Information Administration), International Electricity Emission Factors by Country, 1999–2002; EIA: Washington, DC, USA, (2007). Available online: [http://www.eia.doe.gov/oiaf/1605/excel/electricity\\_factors\\_99-02country.xls](http://www.eia.doe.gov/oiaf/1605/excel/electricity_factors_99-02country.xls) (accessed on 10 September 2010).

---

US EIA (Energy Information Administration). (2009) Annual Energy Review 2008. Report No. DOE/EIA-0384(2008) Release Date: June 26, 2009. Available: <http://www.eia.doe.gov/aer/pdf/aer.pdf>.

US EIA (Energy Information Administration). (2011). Levelized Cost of New Generation Resources in the Annual Energy Outlook 2011, [http://205.254.135.24/oiaf/aeo/pdf/2016levelized\\_costs\\_aeo2011.pdf](http://205.254.135.24/oiaf/aeo/pdf/2016levelized_costs_aeo2011.pdf), accessed on Apr. 15, 2012.

US EIA, Annual Energy Outlook 2009, With Projections to 2030, DOE, [www.eia.doe.gov/oiaf/aeo/](http://www.eia.doe.gov/oiaf/aeo/)

US Energy Information Administration (EIA). “China: background”, <http://www.eia.doe.gov/cabs/China/Background.html>

US Energy Information Administration (EIA). “Electric Power Annual 2006”, <http://tonto.eia.doe.gov/FTP/ROOT/electricity/034806.pdf>

US Energy Information Administration (EIA). “South Korea: background”, (2010), [http://www.eia.doe.gov/emeu/cabs/South\\_Korea/Background.html](http://www.eia.doe.gov/emeu/cabs/South_Korea/Background.html)

US EPA (Environmental Protection Agency), “Inventory of U.S. Greenhouse Gas Emissions and Sinks: 1990 – 2007.” Available: [http://www.epa.gov/climatechange/emissions/downloads09/GHG2007entire\\_report-508.pdf](http://www.epa.gov/climatechange/emissions/downloads09/GHG2007entire_report-508.pdf)

UTC, Purecell200 Heat and Power Solution Brochure

Viebahn P, Krewitt W (2003) Fuel Cell Systems, Final Report. ECLIPSE ([www.eclipse-eu.org](http://www.eclipse-eu.org)), DLR, Germany.

Viebahn, P.; Krewitt, W. (2003) Environmental and Ecological Life Cycle Inventories for Present and Future Power Systems in Europe (ECLIPSE); European Commission, DG Research (Project No. NNE5-2001-00071): Brussels, Belgium.

World Energy Council. (2004). “Comparison of Energy Systems Using Life Cycle Assessment.” ISBN 0 946121 16 8.. Available: <http://www.worldenergy.org/documents/lca2.pdf>.

---

Wuebbles DJ, Atul KJ. (2001) Concerns about climate change and the role of fossil fuel use. *Fuel Process Technol* 71:99–119.

Yuan C, Zhang T, Rangarajan A, Dornfeld D, Ziemba B, Whitbeck R. (2006) A Decision-based Analysis of Compressed Air Usage Patterns in Automotive Manufacturing. *Journal of Manufacturing Systems* 25 (4), 293-300.

Yuan C. and D. Dornfeld., (2009) “Reducing the Environmental Footprint and Economic Costs of Automotive Manufacturing through an Alternative Energy Supply”, *Transaction of North America Manufacturing Research Institute*, Vol. 37, pp.427-434.

Yuan, Y. (2009) “A System Approach for Reducing the Environmental Impact of Manufacturing and Sustainability Improvement of Nano-scale Manufacturing”, Ph.D. dissertation, University of California, Berkeley

Zhai, Q., Alberts, S., Cao, H.J., Zhao, S. Yuan, C. (2010) “Strength Analysis of International Feed-in Tariff Promotion of Clean Energy Applications for Greenhouse Gas Emission Mitigation”, *Proceedings of IEEE Intl. Symp. on Sustainable Systems & Technology*, May 16-19, Washington D.C.

Zhai, Q.; Cao, H.; Zhao, X.; Yuan, C. (2011). Cost Benefit Analysis of Using Clean EnergySupplies to Reduce Greenhouse Gas Emissions of Global Automotive Manufacturing. *Energies* 4, 1478-1494



---

## CURRICULUM VITAE

### Qiang Zhai

#### Education

Ph.D. (2012), Mechanical Engineering, University of Wisconsin Milwaukee, Milwaukee, WI

M.S. (2004), BE (2000), Naval Architecture and Ocean Engineering, Shanghai Jiao Tong University, Shanghai, China

Dissertation Title: Application Potential of Solar PV, Wind and Fuel Cells Technologies for Global Sustainability Improvement

#### Professional Experience

Det Norske Veritas USA, Approval Center, Intern (2012)

J&A Marine Consultant Co., Ltd., Shanghai, China, Superintendent (2008)

China Classification Society (CCS), Shanghai, China, Surveyor (2004-2007)

#### Teaching Assistance

Finite Element Analysis, ANSYS Lab 2011

Engineering Fundamentals, ProE Lab 2010-2011

#### Research Assistance

Department of Energy (DOE) Industrial Assessment Center (IAC) at University of Wisconsin Milwaukee Since 2011

General Motors Sustainability Improvement Project (Clean Energy Supply) 2009-2010

#### Training

Wisconsin Integrated Resource Management Conference, Wisconsin Dells, WI 2012

---

DOE Industrial Assessment Center Lead Student Meeting, Chicago, IL 2011

### Reviewer

ASME International Manufacturing Science and Engineering Conference (MSEC), International Symposium on Sustainable Systems and Technology (ISSST), International Offshore (Ocean) and Polar Engineering Conference (ISOPE), Environmental Progress & Sustainable Energy, International Journal of Green Energy, Journal of Mechanical Engineering

### Peer- Reviewed Journal Articles

**Zhai, Q.;** Cao, H.; Zhao, X.; Yuan, C. Cost Benefit Analysis of Using Clean Energy Supplies to Reduce Greenhouse Gas Emissions of Global Automotive Manufacturing. *Energies* 2011, 4, 1478-1494.

Cao, H., **Zhai, Q.**, Zhao, X., Yuan, C. “Greenhouse gas emission mitigation of global automotive manufacturing through Clean Energy Supply”, *Transactions of NAMRI/SME*, Vol.39, 2011.

Shi Z., **Zhai Q.**, Li Y. 2004/12 Progress in Estuarine Studies, Marine Sciences, Vol. 28, No.12/2004.

Yuan, C., Zhai, Q, Dornfeld, D. “A three dimensional system approach for environmentally sustainable manufacturing”, *CIRP Annals-Manufacturing Technology*, 61(1), 2012, pp.39-42.

**Zhai Q.**, Cao, H.J., Zhao, X., Yuan, C. “Assessing the application potential of Solar PV, Wind, and Fuel Cell technologies for greenhouse gas mitigation of global automotive manufacturing”, *Renewable Energy*, under review.

Yuan, C. and **Zhai Q.** “A General Framework for Temporal Discounting in Life Cycle Assessment”, *Journal of IndustrialEcology*, under revision.

### PEER-REVIEWED CONFERENCE PROCEEDINGS

**Zhai Q.**, Zhao X., Yuan C., “A Cost Benefit Trend Analysis of Solar Photovoltaic Supply for Greenhouse Gas Emission Mitigation of Global Automotive Manufacturing”, *Proceedings of ISSST 2012*, May 16-18, 2012, Boston, Mass., USA,(abstract)

---

**Zhai, Q.**, Yuan, C. “Separating Manufacturing Metal Chips for Recycling through a Combined Hydrodynamic and Electromagnetic Approach”, Proceedings of 19th CIRP International Conference on Life Cycle Engineering, May 23-25, 2012, Berkeley, CA.

Xiaochuan Yu, Hooi-Siang Kang, Liqing Huang, Yonghe Xie, **Qiang Zhai**, “Dynamic response control of a jacket platform using MR dampers based on an inverse dynamic model”, ISOPE-2011, The Twenty First (2011) International Offshore and Polar Engineering Conference, June 19–24, 2011, Maui, Hawaii, USA

**Zhai, Q.**, Yuan, C. “A Framework for Temporal Discounting in Life Cycle Assessment”, Abstract, Proceedings of 6<sup>th</sup> International Conference on Industrial Ecology, June 7-10, 2011, Berkeley, CA.

**Zhai, Q.**, Crowley, B, Yuan, C. “Temporal Discounting for Life Cycle Assessment: Differences between Environmental Discounting and Economic Discounting”, abstract, Proceedings of IEEE International Symp. on Sustainable Systems & Technology, May 16-18, 2011, Chicago, IL.

**Zhai, Q.**, Cao, HJ, Zhao, X., Yuan, C. “Reducing Greenhouse Gas Emissions of Global Automotive Manufacturing through Clean Energy Supply: a Cost Benefit Analysis”, abstract, Proceedings of IEEE Intl. Symp. on Sustainable Systems & Technology, May 16-18, 2011, Chicago, IL.

**Zhai, Q.**, Ciardo, K., Yuan, C. “Temporal Discounting for Life Cycle Assessment: Perspectives and Mechanisms”, Proceedings of 17th CIRP International Conference on Life Cycle Engineering, pp. 46-52, May 19-21, 2010, Hefei, China.

**Zhai, Q.**, Alberts, S., Cao, H.J., Zhao, S. Yuan, C. “Strength Analysis of International Feed-in Tariff Promotion of Clean Energy Applications for Greenhouse Gas Emission Mitigation”, Proceedings of IEEE Intl. Symp. On Sustainable Systems & Technology, May 16-19, 2010, Washington D.C.

Cao, H. J., **Zhai, Q.**, Alberts, S., Zhao, S., Yuan, C. “Greenhouse Gas Emission Mitigation of Global Automotive Manufacturing through Clean Energy Supply” abstract, Proceedings of IEEE International Symp. on Sustainable Systems and Technology, May 16-19, 2010, Washington D.C.