

August 2018

Compactifications of Manifolds with Boundary

Shijie Gu

University of Wisconsin-Milwaukee

Follow this and additional works at: <https://dc.uwm.edu/etd>

 Part of the [Other Mathematics Commons](#)

Recommended Citation

Gu, Shijie, "Compactifications of Manifolds with Boundary" (2018). *Theses and Dissertations*. 1812.
<https://dc.uwm.edu/etd/1812>

This Dissertation is brought to you for free and open access by UWM Digital Commons. It has been accepted for inclusion in Theses and Dissertations by an authorized administrator of UWM Digital Commons. For more information, please contact open-access@uwm.edu.

COMPACTIFICATIONS OF MANIFOLDS
WITH BOUNDARY

by

Shijie Gu

A Dissertation Submitted in
Partial Fulfillment of the
Requirements for the Degree of

Doctor of Philosophy
in Mathematics

at

The University of Wisconsin-Milwaukee
August 2018

ABSTRACT

COMPACTIFICATIONS OF MANIFOLDS
WITH BOUNDARY

by

Shijie Gu

The University of Wisconsin-Milwaukee, 2018
Under the Supervision of Professor Craig Guilbault

This dissertation is concerned with compactifications of high-dimensional manifolds. Siebenmann’s iconic 1965 dissertation [Sie65] provided necessary and sufficient conditions for an open manifold M^m ($m \geq 6$) to be compactifiable by addition of a manifold boundary. His theorem extends easily to cases where M^m is noncompact with compact boundary; however when ∂M^m is noncompact, the situation is more complicated. The goal becomes a “completion” of M^m , ie, a compact manifold \widehat{M}^m containing a compactum $A \subseteq \partial M^m$ such that $\widehat{M}^m \setminus A \approx M^m$. Siebenmann did some initial work on this topic, and O’Brien [O’B83] extended that work to an important special case. But, until now, a complete characterization had yet to emerge. Here we provide such a characterization.

Our second main theorem involves \mathcal{Z} -compactifications. An important open question asks whether a well-known set of conditions laid out by Chapman and Siebenmann [CS76] guarantee \mathcal{Z} -compactifiability for a manifold M^m . We cannot answer that question, but we do show that those conditions are satisfied if and only if $M^m \times [0, 1]$ is \mathcal{Z} -compactifiable. A key ingredient in our proof is the above Manifold Completion Theorem—an application that partly explains our current interest in that topic, and also illustrates the utility of the π_1 -condition found in that theorem. Chapter 1 is based on joint work with Professor Craig Guilbault [GG17].

At last, we obtain a complete characterization of pseudo-collarable n -manifolds for $n \geq 6$. This extends earlier work by Guilbault and Tinsley to allow for manifolds with noncompact boundary. In the same way that their work can be viewed as an extension of Siebenmann's dissertation that can be applied to manifolds with non-stable fundamental group at infinity, Pseudo-collarability Characterization Theorem can also be viewed as an extension of Manifold Completion Theorem in a manner that is applicable to manifolds whose fundamental group at infinity is not peripherally stable.

TABLE OF CONTENTS

Introduction		1
1 Compactifications of Manifolds with Boundary		3
1.0.1	The Manifold Completion Theorem.	4
1.0.2	The Stable \mathcal{Z} -compactification Theorem for Manifolds	5
1.0.3	Outline of this chapter	6
1.1	Manifold completions in dimensions < 6	6
1.2	Conventions, notation, and terminology	7
1.3	Ends, pro- π_1 , the peripheral π_1 -stability, and the peripheral perfect semistability condition	8
1.3.1	Neighborhoods of infinity, partial neighborhoods of infinity, and ends	8
1.3.2	The fundamental group of an end	9
1.3.3	Relative connectedness, relative π_1 -stability, the peripheral π_1 -stability condition, relatively perfectly se-mistablility, and the peripheral perfect semistability condition.	12
1.4	Finite domination and inward tameness	15
1.5	Finite homotopy type and the σ_∞ -obstruction	19
1.6	The τ_∞ -obstruction	21
1.7	Geometric characterization of completable manifolds and a review of h- and s-cobordisms	23
1.8	Proof of the Manifold Completion Theorem: necessity	26

1.9	Proof of the Manifold Completion Theorem: sufficiency	28
1.10	\mathcal{Z} -compactifications and the proof of Theorem 1.0.2	32
1.11	A counterexample to a question of O'Brien	32
1.12	Proof of Lemma 1.3.7	34
2	Characterization of pseudo-collarable manifolds with boundary	40
2.1	Concatenation of one-sided h -precobordisms	42
2.2	Proof of Theorem 2.0.5: necessity	46
2.3	Proof of Theorem 2.0.5: sufficiency	47
2.4	Questions	51
	Bibliography	53
	Curriculum Vitae	57

LIST OF FIGURES

1.1	Decomposition of M^m into $\{W_i\}_{i=1}^\infty$	22
1.2	Decomposing completed M^m into product cobordisms.	24
1.3	$V_i^j \approx \partial V_i^j \times [0, 1)$ contained in $N_i^j \setminus \partial M^m$	30
2.1	A concatenation of relative one-sided h -cobordisms.	43
2.2	A_i is in blue and B'_i is in black. The union of red and blue arcs is P	45
2.3	V_i^j is a homotopy collar.	50

ACKNOWLEDGMENTS

I would like to express the deepest appreciation to my advisor Professor Craig Guilbault who has shown the attitude and the substance of a genius: he continually and persuasively conveyed a spirit of adventure in regard to research and scholarship, and an excitement in regard to teaching. Without his supervision and constant help this thesis would not have been possible.

Many thanks to Professor Bob Daverman, my academic grandfather, unofficial mentor and collaborator, for introducing me to the wonderland of geometric topology and hunting together in wild topology.

Hearty thanks to Professor Ric Ancel, Professor Chris Hruska and Professor Boris Okun for many enlightening conversations and for being my sounding board as this work progressed.

Special thanks to my family. Words cannot express how grateful I am to my mother and father for all of the sacrifices that you have made on my behalf.

Finally and most importantly, I would like express appreciation to my beloved Yan for persistent support and patient tolerance despite her doubts this project would ever end.

Introduction

This dissertation is about compactifications of manifolds. The “nicest” of these compactifications is the addition of a boundary to an open manifold (or to a manifold with compact boundary). That was the topic of Siebenmann’s iconic 1965 dissertation [Sie65]. When a manifold M^m has noncompact boundary, one seeks a compactification which completes the boundary of M^m . That is a more delicate problem. Siebenmann addressed a very special case in his 1965 dissertation [Sie65] and O’Brien [O’B83] extended that work to cases where M^m and boundary of M^m are both 1-ended. In Chapter 1, we present a full characterization—Manifold Completion Theorem, thereby completing an unfinished chapter in the study of noncompact manifolds. In the rest of Chapter 1, we demonstrate a nice application of Manifold Completion Theorem to \mathcal{Z} -compactifications. An important open question asks whether a well-known set of conditions laid out by Chapman and Siebenmann [CS76] guarantee \mathcal{Z} -compactifiability for a manifold M^m . We cannot answer that question, but we do show that those conditions are satisfied if and only if $M^m \times [0, 1]$ is \mathcal{Z} -compactifiable. Chapter 1 is based on joint work with Professor Craig Guilbault [GG17].

One of the beauties of Manifold Completion Theorem is the simple structure it places on the ends of certain manifolds. However, this simplicity largely limits the class of manifolds to which the theorem applies. Many interesting and important noncompact manifolds are too complicated at infinity to be completable. Usually, the periperal stability in Manifold Completion Theorem can be easily violated. So, it is important to produce a characterization to classify manifolds satisfying less rigid structures on their ends. In Chapter 2, we achieve this goal by obtaining a

complete characterization of pseudo-collarable n -manifolds for $n \geq 6$. This extends earlier work by Guilbault and Tinsley [Gui00, GT03, GT06] to allow for manifolds with noncompact boundary. In the same way that their work can be viewed as a natural extension of Siebenmann's dissertation that can be applied to manifolds with non-stable fundamental group at infinity, Pseudo-collarability Characterization Theorem can also be viewed as an extension of Manifold Completion Theorem in a manner that is applicable to manifolds whose fundamental group at infinity is not peripherally stable.

Chapter 1

Compactifications of Manifolds with Boundary

This chapter offers an exploration about “nice” compactifications of high-dimensional manifolds. The simplest of these compactification is the addition of a boundary to an open manifold. That was the topic of Siebenmann’s famous 1965 dissertation [Sie65], the main result of which can easily be extended to include noncompact manifolds with compact boundaries. When M^m has noncompact boundary, one may ask for a compactification \widehat{M}^m that “completes” ∂M^m . That is a more delicate problem. Siebenmann addressed a very special case in his dissertation, before O’Brien [O’B83] characterized completable n -manifolds in the case where M^m and ∂M^m are both 1-ended. Since completable manifolds can have infinitely many (non-isolated) ends, O’Brien’s theorem does not imply a full characterization of completable n -manifolds. We obtain such a characterization here, thereby completing an unfinished chapter in the study of noncompact manifolds.

A second type of compactification considered here is the \mathcal{Z} -compactification. These are similar to the compactifications discussed above—in fact, those are special cases—but \mathcal{Z} -compactifications are more flexible. For example, a \mathcal{Z} -boundary for an open manifold need not be a manifold, and a manifold that admits no completion can admit a \mathcal{Z} -compactification. These compactifications have proven to be useful in both geometric group theory and manifold topology, for example, in attacks on the Borel and Novikov Conjectures. A major open problem (in our minds) is

a characterization of \mathcal{Z} -compactifiable manifolds. A set of necessary conditions was identified by Chapman and Siebenmann [CS76], and it is hoped that those conditions are sufficient. We prove what might be viewed the next best thing: If M^m satisfies the Chapman-Siebenmann conditions (and $m \neq 4$), then $M^m \times [0, 1]$ is \mathcal{Z} -compactifiable. We do this by proving that $M^m \times [0, 1]$ is completable—an application that partly explains the renewed interest in manifold completions, and also illustrates the usefulness of the conditions found in the Manifold Completion Theorem.

1.0.1 The Manifold Completion Theorem.

An m -manifold M^m with (possibly empty) boundary is *completable* if there exists a compact manifold \widehat{M}^m and a compactum $C \subseteq \partial\widehat{M}^m$ such that $\widehat{M}^m \setminus C$ is homeomorphic to M^m . In this case \widehat{M}^m is called a (*manifold*) *completion* of M^m . A primary goal of this paper is the following characterization theorem for $m \geq 6$. Definitions will be provided subsequently.

Theorem 1.0.1 (Manifold Completion Theorem). *An m -manifold M^m ($m \geq 6$) is completable if and only if*

- (a) M^m is inward tame,
- (b) M^m is peripherally π_1 -stable at infinity,
- (c) $\sigma_\infty(M^m) \in \varprojlim \left\{ \widetilde{K}_0(\pi_1(N)) \mid N \text{ a clean neighborhood of infinity} \right\}$ is zero, and
- (d) $\tau_\infty(M^m) \in \varprojlim^1 \left\{ \text{Wh}(\pi_1(N)) \mid N \text{ a clean neighborhood of infinity} \right\}$ is zero.

Remark 1. Several comments are in order:

1. Dimensions ≤ 5 are discussed briefly in §1.1; our main focus is $m \geq 6$.
2. If ∂M^m is compact and M^m is inward tame then M^m has finitely many ends (see §1.4), so the ends are isolated and disjoint from ∂M^m . In that case Theorem 1.0.1 reduces to Siebenmann’s dissertation [Sie65]. As such, Theorem 1.0.1 can be viewed as a generalization of [Sie65].

3. The special case of the Manifold Completion Theorem, where M^m and ∂M^m are 1-ended, was proved by O’Brien [O’B83]; that is where “peripheral π_1 -stability” was first defined. But since candidates for completion can be infinite-ended (e.g., let $C \subseteq S^{m-1}$ be a Cantor set and $M^m = B^m \setminus C$), the general theorem is not a corollary. In the process of generalizing [O’B83], we simplify the proof presented there and correct an error in the formulation of Condition (c). We also exhibit some interesting examples which answer a question posed by O’Brien about a possible weakening Condition (b).
4. If Condition (b) is removed from Theorem 1.0.1, one arrives at Chapman and Siebenmann’s conditions for characterizing \mathcal{Z} -compactifiable Hilbert cube manifolds [CS76]. A \mathcal{Z} -compactification theorem for finite-dimensional manifolds is the subject of the second main result of this paper. We will describe that theorem and the necessary definitions now.

1.0.2 The Stable \mathcal{Z} -compactification Theorem for Manifolds

To extend the idea of a completion to Hilbert cube manifolds Chapman and Siebenmann introduced the notion of a “ \mathcal{Z} -compactification”. A compactification $\widehat{X} = X \sqcup Z$ of a space X is a \mathcal{Z} -compactification if there is a homotopy $H : \widehat{X} \times [0, 1] \rightarrow \widehat{X}$ such that $H_0 = \text{id}_{\widehat{X}}$ and $H_t(\widehat{X}) \subseteq X$ for all $t > 0$. Subsequently, this notion has been fruitfully applied to more general spaces—notably, finite-dimensional manifolds and complexes; see, for example, [BM91],[CP95],[FW95],[AG99], and [FL05]. A completion of a finite-dimensional manifold is a \mathcal{Z} -compactification, but a \mathcal{Z} -compactification need not be a completion. In fact, a manifold that allows no completion can still admit a \mathcal{Z} -compactification; the exotic universal covers constructed by Mike Davis are some of the most striking examples (just apply [ADG97]). Such manifolds must satisfy Conditions (a), (c) and (d), but the converse remains open.

Question. *Does every finite-dimensional manifold that satisfies Conditions (a), (c) and (d) of Theorem 1.0.1 admit a \mathcal{Z} -compactification?*

This question was posed more generally in [CS76] for locally compact ANRs, but in [Gui01] a 2-dimensional polyhedral counterexample was constructed. The manifold version remains open. In this paper, we prove a best possible “stabilization theorem” for manifolds.

Theorem 1.0.2 (Stable \mathcal{Z} -compactification Theorem for Manifolds). *An m -manifold M^m ($m \geq 5$) satisfies Conditions (a), (c) and (d) of Theorem 1.0.1, if and only if $M^m \times [0, 1]$ admits a \mathcal{Z} -compactification. In fact, $M^m \times [0, 1]$ is completable if and only if M^m satisfies those conditions.*

Remark 2. In [Fer00], Ferry showed that if a locally finite k -dimensional polyhedron X satisfies Conditions (a), (c) and (d), then $X \times [0, 1]^{2k+5}$ is \mathcal{Z} -compactifiable. Theorem 1.0.1 can be viewed as a sharpening of Ferry’s theorem in cases where X is a manifold.

1.0.3 Outline of this chapter

The remainder of this chapter is organized as follows. In §1.1 we review the status of Theorem 1.0.1 in dimensions < 6 . In §1.2 we fix some terminology and notation; then in §1.3-1.6, we carefully discuss each of the four conditions present in Theorem 1.0.1. In §1.8-1.9 we prove Theorem 1.0.1, and in §1.10 we prove Theorem 1.0.2. In §1.11 we provide a counterexample to a question posed in [O’B83] about a possible relaxation of Condition (b), and in §1.12 we provide the proof of a technical lemma that was postponed until the end of the chapter.

1.1 Manifold completions in dimensions < 6

The Manifold Completion Theorem is true in dimensions ≤ 3 , but much simpler versions are possible in those dimensions. For example, Tucker [Tuc74] shows that a 3-manifold can be completed if and only if each component of each clean neighborhood of infinity has finitely generated fundamental group—a condition that is implied by inward tameness alone.

In dimension 5 our proof of Theorem 1.0.1 goes through verbatim, provided it is always possible to work in neighborhoods of infinity with boundaries in which Freedman’s 4-dimensional Disk Embedding Theorem holds. That issue is discussed in [Qui82] and [FQ90, §11.9] in the less general setting of Siebenmann’s thesis, but the issues here are the same. In the language of [FQ90]: Theorem 1.0.1 holds provided Condition (b) is strengthened to require the existence of arbitrarily small neighborhoods of infinity with stable peripheral $\text{pro-}\pi_1$ groups that are “good”. A caveat is that, whenever [Fre82] is applied, conclusions are topological, rather than PL or smooth.

Remarkably, Siebenmann’s thesis fails in dimension 4 (see [Wei87] and [KS88]). Counterexamples to his theorem are, of course, counterexamples to Theorem 1.0.1 as well.

As for low-dimensional versions of Theorem 1.0.2: if $m \leq 3$ and M^m satisfies Condition (a) then M^m is completable (hence \mathcal{Z} -compactifiable), so $M^m \times [0, 1]$ is completable and \mathcal{Z} -compactifiable. If $m = 4$, then $M^4 \times [0, 1]$ is a 5-manifold, which (see §1.10) satisfies the conditions of Theorem 1.0.1. Whether that leads to a completion depends on 4-dimensional issues, in particular the “goodness” of the (stable) peripheral fundamental groups of the ends of $M^4 \times [0, 1]$. Those groups are determined by, but are not the same as, the fundamental groups at the ends of M^4 . If desired, a precise group-theoretic condition can be formulated from Proposition 1.10.1 and [Gui07].

1.2 Conventions, notation, and terminology

For convenience, all manifolds are assumed to be piecewise-linear (PL). That assumption is particularly useful for the topic at hand, since numerous instances of “smoothing corners” would be required in the smooth category (an issue that is covered nicely in [O’B83]). With proper attention to such details, analogous theorems can be obtained in the smooth or topological category. Unless stated otherwise, an m -manifold M^m is permitted to have a boundary, denoted ∂M^m . We denote the

manifold interior by $\text{int } M^m$. For $A \subseteq M^m$, the *point-set interior* will be denoted $\text{Int}_{M^m} A$ and the *frontier* by $\text{Fr}_{M^m} A$ (or for conciseness, $\text{Int}_M A$ and the *frontier* by $\text{Fr}_M A$). A *closed manifold* is a compact boundaryless manifold, while an *open manifold* is a non-compact boundaryless manifold.

For $q < m$, a q -dimensional submanifold $Q^q \subseteq M^m$ is *properly embedded* if it is a closed subset of M^m and $Q^q \cap \partial M^m = \partial Q^q$; it is *locally flat* if each $p \in \text{int } Q^q$ has a neighborhood pair homeomorphic to $(\mathbb{R}^m, \mathbb{R}^q)$ and each $p \in \partial Q^q$ has a neighborhood pair homeomorphic to $(\mathbb{R}_+^m, \mathbb{R}_+^q)$. By this definition, the only properly embedded codimension 0 submanifolds of M^m are unions of its connected components; a more useful type of codimension 0 submanifold is the following: a codimension 0 submanifold $Q^m \subseteq M^m$ is *clean* if it is a closed subset of M^m and $\text{Fr}_M Q^m$ is a properly embedded locally flat (hence, bicollared) $(m-1)$ -submanifold of M^m . In that case, $\overline{M^m \setminus Q^m}$ is also clean, and $\text{Fr}_M Q^m$ is a clean codimension 0 submanifold of both ∂Q^m and $\partial(\overline{M^m \setminus Q^m})$.

When the dimension of a manifold or submanifold is clear, we sometimes omit the superscript; for example, denoting a clean codimension 0 submanifold by Q . Similarly, when the ambient space is clear, we denote (point-set) interiors and frontiers by $\text{Int } A$ and $\text{Fr } A$.

For any codimension 0 clean submanifold $Q \subseteq M^m$, let $\partial_M Q$ denote $Q \cap \partial M^m$; alternatively $\partial_M Q = \partial Q \setminus \text{int}(\text{Fr } Q)$. Similarly, we will let $\text{int}_M Q$ denote $Q \cap \text{int } M^m$; alternatively $\text{int}_M Q = Q \setminus \partial M^m$.

1.3 Ends, pro- π_1 , the peripheral π_1 -stability, and the peripheral perfect semistability condition

1.3.1 Neighborhoods of infinity, partial neighborhoods of infinity, and ends

Let M^m be a connected manifold. A *clean neighborhood of infinity* in M^m is a clean codimension 0 submanifold $N \subseteq M^m$ for which $\overline{M^m \setminus N}$ is compact. Equivalently, a clean neighborhood of infinity is a set of the form $\overline{M^m \setminus C}$ where C is a compact

clean codimension 0 submanifold of M^m . A *clean compact exhaustion* of M^m is a sequence $\{C_i\}_{i=1}^\infty$ of clean compact connected codimension 0 submanifolds with $C_i \subseteq \text{Int}_M C_{i+1}$ and $\cup C_i = M^m$. By letting $N_i = \overline{M^m \setminus C_i}$ we obtain the corresponding *cofinal sequence of clean neighborhoods of infinity*. Each such N_i has finitely many components $\{N_i^j\}_{j=1}^{k_i}$. By enlarging C_i to include all of the compact components of N_i , we can arrange that each N_i^j is noncompact; then, by drilling out regular neighborhoods of arcs connecting the various components of each $\text{Fr}_M N_i^j$ (further enlarging C_i), we can also arrange that each $\text{Fr}_M N_i^j$ is connected. A clean N_i with these latter two properties is called a 0-neighborhood of infinity. Most constructions in this paper will begin with a clean compact exhaustion of M^m with a corresponding cofinal sequence of clean 0-neighborhoods of infinity.

Assuming the above arrangement, an *end* ε of M^m is determined by a nested sequence $(N_i^{k_i})_{i=1}^\infty$ of components of the N_i ; each component is called a *neighborhood of ε* . More generally, any subset of M^m that contains one of the $N_i^{k_i}$ is a neighborhood of ε , and any nested sequence $(W_j)_{j=1}^\infty$ of connected neighborhoods of ε , for which $\cap W_j = \emptyset$, also determines the end ε . A more thorough discussion of ends can be found in [Gui16]. Here we will abuse notation slightly by writing $\varepsilon = (N_i^{k_i})_{i=1}^\infty$, keeping in mind that a sequence representing ε is not unique.

At times we will have need to discuss components $\{N^j\}$ of a neighborhood of infinity N without reference to a specific end of M^m . In that situation, we will refer to the N^j as a *partial neighborhoods of infinity for M^m* (*partial 0-neighborhoods* if N is a 0-neighborhood of infinity). Clearly every noncompact clean connected codimension 0 submanifold of M^m with compact frontier is a partial neighborhood of infinity with respect to an appropriately chosen compact C ; if its frontier is connected it is a partial 0-neighborhood of infinity.

1.3.2 The fundamental group of an end

For each end ε of M^m , we will define the *fundamental group at ε* by using inverse sequences. Two inverse sequences of groups $A_0 \xleftarrow{\alpha_1} A_1 \xleftarrow{\alpha_2} A_2 \xleftarrow{\alpha_3} \dots$ and $B_0 \xleftarrow{\beta_1}$

$B_1 \xleftarrow{\beta_2} B_3 \xleftarrow{\beta_3} \dots$ are *pro-isomorphic* if they contain subsequences that fit into a commutative diagram of the form

$$\begin{array}{ccccccc}
G_{i_0} & \xleftarrow{\lambda_{i_0+1,i_1}} & G_{i_1} & \xleftarrow{\lambda_{i_1+1,i_2}} & G_{i_2} & \xleftarrow{\lambda_{i_2+1,i_3}} & G_{i_3} & \dots \\
& \searrow & \swarrow & \searrow & \swarrow & \searrow & \swarrow & \\
& & H_{j_0} & \xleftarrow{\mu_{j_0+1,j_1}} & H_{j_1} & \xleftarrow{\mu_{j_1+1,j_2}} & H_{j_2} & \xleftarrow{\mu_{j_2+1,j_3}} \dots
\end{array} \tag{1.3.1}$$

where the connecting homomorphisms in the subsequences are (as always) compositions of the original maps. An inverse sequence is *stable* if it is pro-isomorphic to a constant sequence $C \xleftarrow{\text{id}} C \xleftarrow{\text{id}} C \xleftarrow{\text{id}} \dots$. Clearly, an inverse sequence is pro-isomorphic to each of its subsequences; it is stable if and only if it contains a subsequence for which the images stabilize in the following manner

$$\begin{array}{ccccccc}
G_0 & \xleftarrow{\lambda_1} & G_1 & \xleftarrow{\lambda_2} & G_2 & \xleftarrow{\lambda_3} & G_3 & \dots \\
& \searrow & \swarrow & \searrow & \swarrow & \searrow & \swarrow & \\
& & \text{Im}(\lambda_1) & \xleftarrow{\cong} & \text{Im}(\lambda_2) & \xleftarrow{\cong} & \text{Im}(\lambda_3) & \xleftarrow{\cong} \dots
\end{array} \tag{1.3.2}$$

where all unlabeled homomorphisms are restrictions or inclusions. (Here we have simplified notation by relabelling the entries in the subsequence with integer subscripts.)

Given an end $\varepsilon = (N_i^{k_i})_{i=1}^\infty$, choose a ray $r : [1, \infty) \rightarrow M^m$ such that $r([i, \infty)) \subseteq N_i^{k_i}$ for each integer $i > 0$ and form the inverse sequence

$$\pi_1(N_1^{k_1}, r(1)) \xleftarrow{\lambda_2} \pi_1(N_2^{k_2}, r(2)) \xleftarrow{\lambda_3} \pi_1(N_3^{k_3}, r(3)) \xleftarrow{\lambda_4} \dots \tag{1.3.3}$$

where each λ_i is an inclusion induced homomorphism composed with the change-of-basepoint isomorphism induced by the path $r|_{[i-1, i]}$. We refer to r as the *base ray* and the sequence (1.3.3) as a representative of the “fundamental group at ε based at r ” —denoted $\text{pro-}\pi_1(\varepsilon, r)$. Any similarly obtained representation (e.g., by choosing a different sequence of neighborhoods of ε) using the same base ray can be seen to be pro-isomorphic. We say *the fundamental group at ε is stable* if (1.3.3) is a stable sequence. A nontrivial (but standard) observation is that both semistability

and stability of ε do not depend on the base ray (or the system of neighborhoods if infinity used to define it). See [Gui16] or [Geo08].

If $\{H_i, \mu_i\}$ can be chosen so that each μ_i is an epimorphism, we say that our inverse sequence is *semistable* (or *Mittag-Leffler*, or *pro-epimorphic*). In this case, it can be arranged that the restriction maps in the bottom row of (1.3.1) are epimorphisms. Similarly, if $\{H_i, \mu_i\}$ can be chosen so that each μ_i is a monomorphism, we say that our inverse sequence is *pro-monomorphic*; it can then be arranged that the restriction maps in the bottom row of (1.3.1) are monomorphisms. It is easy to see that an inverse sequence that is semistable and pro-monomorphic is stable.

Recall that a *commutator* element of a group H is an element of the form $x^{-1}y^{-1}xy$ where $x, y \in H$; and the *commutator subgroup* of H ; denoted $[H, H]$ or $H^{(1)}$, is the subgroup generated by all of its commutators. The group H is *perfect* if $H = [H, H]$. An inverse sequence of groups is *perfectly semistable* if it is pro-isomorphic to an inverse sequence.

$$G_0 \xleftarrow{\lambda_1} G_1 \xleftarrow{\lambda_2} G_2 \xleftarrow{\lambda_3} \dots \quad (1.3.4)$$

of finitely generated groups and surjections where each $\ker(\lambda_i)$ perfect. The following shows that inverse sequences of this type behave well under passage to subsequences.

Lemma 1.3.1. *A composition of surjective group homomorphisms, each having perfect kernels, has perfect kernel. Thus, if an inverse sequence of surjective group homomorphisms has the property that the kernel of each bonding map is perfect, then each of its subsequences also has this property.*

Proof. See [Gui00, Lemma 1].

□

1.3.3 Relative connectedness, relative π_1 -stability, the peripheral π_1 -stability condition, relatively perfectly semistability, and the peripheral perfect semistability condition.

Let Q be a manifold and $A \subseteq \partial Q$. We say that Q is *A-connected at infinity* if Q contains arbitrarily small neighborhoods of infinity V for which $A \cup V$ is connected.

Example 1. If P is a compact manifold with connected boundary, $X \subseteq \partial P$ is a closed set, and $Q = P \setminus X$, then Q has one end for each component of X but Q is ∂Q -connected at infinity. More generally, if B is a clean connected codimension 0 manifold neighborhood of X in ∂P and $A = B \setminus X$, then Q is A -connected at infinity.

The following lemma is straightforward.

Lemma 1.3.2. *Let Q be a noncompact manifold and A a clean codimension 0 submanifold of ∂Q . Then Q is A -connected at infinity if and only if $Q \setminus A$ is 1-ended.*

If $A \subseteq \partial Q$ and Q is A -connected at infinity: let $\{V_i\}$ be a cofinal sequence of clean neighborhoods of infinity for which each $A \cup V_i$ is connected; choose a ray $r : [1, \infty) \rightarrow \text{int } Q$ such that $r([i, \infty)) \subseteq V_i$ for each $i > 0$; and form the inverse sequence

$$\pi_1(A \cup V_1, r(1)) \xleftarrow{\mu_2} \pi_1(A \cup V_2, r(2)) \xleftarrow{\mu_3} \pi_1(A \cup V_3, r(3)) \xleftarrow{\mu_4} \cdots \quad (1.3.5)$$

where bonding homomorphisms are obtained as in (1.3.3). We say Q is *A-perfectly π_1 -semistable at infinity* (resp. *A- π_1 -stable at infinity*) if (1.3.5) is perfectly semistable (resp. stable). Independence of this property from the choices of $\{V_i\}$ and r follows from the traditional theory of ends by applying Lemmas 1.3.2 and 1.3.3. Because each boundary component of a manifold with boundary is collared, the following lemma is true because “throwing away” part of the boundary will preserve the homotopy type of the original manifold.

Lemma 1.3.3. *Let Q be a noncompact manifold and A a clean codimension 0 submanifold of ∂Q for which Q is A -connected at infinity. Then, for any cofinal sequence of clean neighborhoods of infinity $\{V_i\}$ and ray $r : [1, \infty) \rightarrow Q$ as described above, the sequence (1.3.5) is pro-isomorphic to any sequence representing $\text{pro-}\pi_1(Q \setminus A, r)$.*

Proof. It suffices to find a single cofinal sequence of connected neighborhoods of infinity $\{N_i\}$ in $Q \setminus A$ for which the corresponding representation of $\text{pro-}\pi_1(Q \setminus A, r)$ is pro-isomorphic to (1.3.5). Toward that end, for each i let $C_1 \supseteq C_2 \supseteq \dots$ be a nested sequence of relative regular neighborhoods of A in Q such that $\cap C_i = A$. By ‘‘cleanness’’ of the V_i , each C_i can be chosen so that $C_i \cup V_i$ is a clean codimension 0 submanifold of Q which deformation retracts onto $A \cup V_i$. Then $N_i = (C_i \cup V_i) \setminus A$ is a clean neighborhood of infinity in $Q \setminus A$ and $N_i \hookrightarrow C_i \cup V_i$ is a homotopy equivalence. For each i there is a canonical isomorphism $\alpha_i : \pi_1(A \cup V_i, r(i)) \rightarrow \pi_1(N_i, r(i))$ which is the composition

$$\pi_1(A \cup V_i, r(i)) \xrightarrow{\cong} \pi_1(C_i \cup V_i, r(i)) \xleftarrow{\cong} \pi_1(N_i, r(i))$$

These isomorphisms fit into a commuting diagram

$$\begin{array}{ccccccc} \pi_1(A \cup V_1, r(1)) & \xleftarrow{\mu_2} & \pi_1(A \cup V_2, r(2)) & \xleftarrow{\mu_3} & \pi_1(A \cup V_3, r(3)) & \xleftarrow{\mu_4} & \dots \\ \alpha_1 \downarrow \cong & & \alpha_2 \downarrow \cong & & \alpha_3 \downarrow \cong & & \\ \pi_1(N_1, r(1)) & \xleftarrow{\lambda_2} & \pi_1(N_2, r(2)) & \xleftarrow{\lambda_3} & \pi_1(N_3, r(3)) & \xleftarrow{\lambda_4} & \dots \end{array}$$

completing the proof. □

Remark 3. In the above discussion, we allow for the possibility that $A = \emptyset$. In that case, A -connectedness at infinity reduces to 1-endedness and A - π_1 -stability to ordinary π_1 -stability at that end.

Definition 1.3.4. Let M^m be a manifold and ε an end of M^m .

1. M^m is *peripherally locally connected at infinity* if it contains arbitrarily small 0-neighborhoods of infinity N with the property that each component N^j is $\partial_M N^j$ -connected at infinity.

2. M^m is *peripherally locally connected at ε* if ε has arbitrarily small 0-neighborhoods P that are $\partial_M P$ -connected at infinity.

An N with the property described in condition (1) will be called a *strong 0-neighborhood of infinity* for M^m , and a P with the property described in condition (2) will be called a *strong 0-neighborhood of ε* . More generally, any connected partial 0-neighborhood of infinity Q that is $\partial_M Q$ -connected at infinity will be called a *strong partial 0-neighborhood of infinity*.

Lemma 1.3.5. *M^m is peripherally locally connected at infinity iff M^m is peripherally locally connected at each of its ends.*

Proof. Clearly the initial condition implies the latter. For the converse, let N' be an arbitrary neighborhood of infinity in M^m and for each end ε , let P_ε be a 0-neighborhoods of ε , contained in N' , which is $\partial_M P_\varepsilon$ -connected at infinity. By compactness of the Freudenthal boundary of M^m , there is a finite subcollection $\{P_{\varepsilon_k}\}_{k=1}^n$ that covers the end of M^m ; in other words, $C = \overline{M^m - \cup_{k=1}^n P_{\varepsilon_k}}$ is compact. If the P_{ε_k} are pairwise disjoint, we are finished; just let $N = \cup_{k=1}^n P_{\varepsilon_k}$. If not, adjust the P_{ε_k} within N' so they are in general position with respect to one another, then let $\{Q_j\}_{j=1}^s$ be the set of components of $\cup_{k=1}^n P_{\varepsilon_k}$ and note that each Q_j is a $\partial_M Q_j$ -connected partial 0-neighborhood of infinity. \square

Remark 4. In the next section, we show that *every* inward tame manifold M^m is peripherally locally connected at infinity. As a consequence, that condition plays less prominent role than the next definition.

Definition 1.3.6. Let M^m be a manifold and ε an end of M^m .

1. M^m is *peripherally perfectly π_1 -semistable at infinity* (resp. *peripherally π_1 -stable at infinity*) if it contains arbitrarily small strong 0-neighborhoods of infinity N with the property that each component N^j is $\partial_M N^j$ -perfectly π_1 -semistable at infinity (resp. $\partial_M N^j$ - π_1 -stable at infinity).

2. M^m is *peripherally perfectly π_1 -semistable at ε* (resp. *peripherally π_1 -stable at ε*) if ε has arbitrarily small strong 0-neighborhoods P that are $\partial_M P$ -perfectly π_1 -semistable at infinity (resp. $\partial_M P$ - π_1 -stable at infinity).

If M^m contains arbitrarily small 0-neighborhoods of infinity N with the property that each component N^j is $\partial_M N^j$ -perfectly semistable at infinity, then those components provide arbitrarily small neighborhoods of the ends satisfying the necessary perfectly semistable condition. Thus, it's clear that peripheral perfect π_1 -semistability at infinity implies peripheral perfect π_1 -semistability at each end.

It is easy to see that peripheral π_1 -stability at infinity implies peripheral π_1 -stability at each end; and when M^m is finite-ended, peripheral π_1 -stability at each end implies peripheral π_1 -stability at infinity. A argument could be made for defining peripheral π_1 -stability at infinity to mean “peripherally π_1 -stability at each end”. For us, that point is moot; in the presence of inward tameness the two alternatives are equivalent.

Lemma 1.3.7. *An inward tame manifold M^m is peripherally π_1 -stable at infinity if and only if it is peripherally π_1 -stable at each of its ends.*

Proof of this lemma is technical, and not central to the main argument. For that reason, we save the proof for later (see §1.12). Although it is not needed here, it would be interesting to know whether Lemma 1.3.7 holds without the assumption of inward tameness.

1.4 Finite domination and inward tameness

A topological space P is *finitely dominated* if there exists a finite polyhedron K and maps $u : P \rightarrow K$ and $d : K \rightarrow P$ such that $d \circ u \simeq \text{id}_P$. If choices can be made so both $d \circ u \simeq \text{id}_P$ and $u \circ d \simeq \text{id}_K$, i.e., $P \simeq K$, we say P has *finite homotopy type*. For simplicity, we will restrict our attention to cases where P is a locally finite polyhedron—a class that contains the (PL) manifolds, submanifolds, and subspaces considered here.

Lemma 1.4.1. *Let M^m be a manifold and $A \subseteq \partial M$. Then M^m is finitely dominated [resp., has finite homotopy type] if and only if $M^m \setminus A$ is finitely dominated [resp., has finite homotopy type].*

Proof. $M^m \setminus A \hookrightarrow M^m$ is a homotopy equivalence, and these properties are homotopy invariants. \square

Lemma 1.4.2. *A locally finite polyhedron P is finitely dominated if and only if there exists a homotopy $H : P \times [0, 1] \rightarrow P$ such that $H_0 = \text{id}_P$ and $\overline{H_1(P)}$ is compact.*

Proof. Assuming a finite domination, as described above, the homotopy between id_P and $d \circ u$ has the desired property. For the converse, let K be a compact polyhedral neighborhood of $\overline{H_1(P)}$, $u : K \hookrightarrow P$, and $d = H_1 : P \rightarrow K$. \square

A locally finite polyhedron P is *inward tame* if it contains arbitrarily small polyhedral neighborhoods of infinity that are finitely dominated. Equivalently, P contains a cofinal sequence $\{N_i\}$ of closed polyhedral neighborhoods of infinity each admitting a “taming homotopy” $H : N_i \times [0, 1] \rightarrow N_i$ that pulls N_i into a compact subset of itself. By an application of the Homotopy Extension Property (similar to [GM17, Lemma 3.4]) we can require taming homotopies to be fixed on $\text{Fr } N_i$. From there, it is easy to see that, in an inward tame polyhedron, *every* closed neighborhood of infinity admits a taming homotopy.¹

Lemma 1.4.3. *Let M^m be a manifold and A a clean codimension 0 submanifold of ∂M^m . If M^m is inward tame then so is $M^m \setminus A$.*

Proof. For an arbitrarily small clean neighborhood of infinity N in M^m , let H be a taming homotopy that fixes $\text{Fr } N$. Then H extends via the identity to a homotopy that pulls $A \cup N$ into a compact subset of itself, so $A \cup N$ is finitely dominated. Arguing as in Lemma 1.3.3, $M^m \setminus A$ has arbitrarily small clean neighborhoods of infinity homotopy equivalent to such an $A \cup N$. \square

¹For a discussion of “tameness” terminology and its variants, see [Gui16, §3.5.5].

Remark 5. Important cases of Lemma 1.4.3 are when $A = \partial M^m$ and when V is a clean neighborhood of infinity (or a component of one) and $A = \partial_M V$. Notice that Lemma 1.4.3 is valid when M^m is compact and H is the “empty map”.

A finitely dominated space has finitely generated homology, from which it can be shown that an inward tame manifold with compact boundary is finite-ended (see [GT03, Prop.3.1]). That conclusion fails for manifolds with noncompact boundary; see item (3) of Remark 1. The following variation is crucial to this paper.

Proposition 1.4.4. *If a noncompact connected manifold M^m and its boundary each have finitely generated homology, then M^m has finitely many ends. More specifically, the number of ends of M^m is bounded above by $\dim H_{m-1}(M^m, \partial M^m; \mathbb{Z}_2) + 1$.*

Proof. Let C be a clean connected compact codimension 0 submanifold of M^m , with the property that $N = \overline{M^m \setminus C}$ is a 0-neighborhood of infinity, and let $\{N^j\}_{j=1}^k$ be the collection of connected components of N^n . It suffices to show that $k \leq \dim H_{m-1}(M^m, \partial M^m; \mathbb{Z}_2) + 1$. For the remainder of this proof (and only this proof), all homology is with \mathbb{Z}_2 -coefficients.

Note that ∂C is the union of clean codimension 0 submanifolds $\partial_M C$ and $\text{Fr } C$, which intersect in their common boundary $\partial(\text{Fr } C)$. So by a generalized version of Poincaré duality [Hat02, Th.3.43] and the Universal Coefficients Theorem, for all i , we have

$$H_i(C, \partial_M C) \cong H_{m-i}(C, \text{Fr } C). \quad (1.4.1)$$

CLAIM 1. $\dim H_{m-1}(C, \partial_M C) \geq k - 1$.

By the long exact sequence for the pair $(C, \text{Fr } C)$, we have

$$\begin{array}{ccccccc} \cdots & \rightarrow & H_1(C, \text{Fr } C) & \rightarrow & \tilde{H}_0(\text{Fr } C) & \rightarrow & \tilde{H}_0(C) \\ & & & & \parallel & & \parallel \\ & & & & (\mathbb{Z}_2)^{k-1} & & 0 \end{array}$$

So the claim follows from identity (1.4.1).

CLAIM 2. $\text{rank } H_{m-1}(N, \partial_M N) \geq k$

This claim follows from the long exact sequence for the triple $(N, \partial N, \partial_M N)$

$$\begin{array}{ccccccc} \rightarrow & H_m(N, \partial N) & \rightarrow & H_{m-1}(\partial N, \partial_M N) & \twoheadrightarrow & H_{m-1}(N, \partial_M N) & \rightarrow \\ & \parallel & & \parallel & & & \\ & 0 & & (\mathbb{Z}_2)^k & & & \end{array}$$

where triviality of $H_m(N, \partial N)$ is due to the noncompactness of all components of N , and the middle equality is from excision.

The relative Mayer-Vietoris Theorem for pairs [Hat02, §2.2], applied to $(M^m, \partial M^m)$ expressed as $(C \cup N, \partial_M C \cup \partial_M N)$, contains

$$H_{m-1}(\text{Fr } C, \partial \text{Fr } C) \rightarrow H_{m-1}(C, \partial_M C) \oplus H_{m-1}(N, \partial_M N) \rightarrow H_{m-1}(M^m, \partial M^m) \quad (1.4.2)$$

from which we can deduce

$$\begin{aligned} \dim(H_{m-1}(C, \partial_M C) \oplus H_{m-1}(N, \partial_M N)) &\leq \\ &\dim H_{m-1}(\text{Fr } C, \partial \text{Fr } C) + \dim H_{m-1}(M^m, \partial M^m) \end{aligned}$$

Since $H_{m-1}(\text{Fr } C, \partial \text{Fr } C) \cong (\mathbb{Z}_2)^k$ (from excision), then by Claims 1 and 2 we have

$$(k-1) + k \leq k + \dim H_{m-1}(M^m, \partial M^m).$$

So $k \leq \dim H_{m-1}(M^m, \partial M^m) + 1$. □

Corollary 1.4.5. *If M^m is inward tame, then M^m is peripherally locally connected at infinity.*

Proof. By Lemma 1.3.2, it suffices to show that each compact codimension 0 clean submanifold $D \subseteq M^m$ is contained in a compact codimension 0 clean submanifold $C \subseteq M^m$ so that if $N = \overline{M^m \setminus C}$, then each component N^j of N has the property that $N^j \setminus \partial M^m$ is 1-ended.

Since M^m is inward tame, each of its clean neighborhoods of infinity is finitely dominated, so $\overline{M^m \setminus D}$ has finitely many components, each of which is finitely dominated. Let P^l be one of those components. Then, $\text{Fr } P^l$ is a compact clean

codimension 0 submanifold of ∂D , whose interior is the boundary of $P^l \setminus \partial M^m$. Since $\text{int}(\text{Fr } P^l)$ and $P^l \setminus \partial M^m$ each have finitely generated homology ($P^l \setminus \partial M^m$ is finitely dominated), then by Proposition 1.4.4, $P^l \setminus \partial M^m$ has finitely many ends. Choose a compact clean codimension 0 submanifold K_l of $P^l \setminus \partial M^m$ that intersects $\text{int}(\text{Fr } P^l)$ nontrivially and has exactly one (unbounded) complementary component in $P^l \setminus \partial M^m$ for each of those ends. After doing this for each of the component P^l of $\overline{M^m \setminus D}$, let $C = D \cup (\cup K_l)$. \square

1.5 Finite homotopy type and the σ_∞ -obstruction

Finitely generated projective left Λ -modules S and T are *stably equivalent* if there exist finitely generated free Λ -modules F_1 and F_2 such that $S \oplus F_1 \cong T \oplus F_2$. Under the operation of direct sum, the stable equivalence classes of finitely generated projective modules form a group $\tilde{K}_0(\Lambda)$, the *reduced projective class group* of Λ . In [Wal65], Wall associated to each path connected finitely dominated space P a well-defined $\sigma(P) \in \tilde{K}_0(\mathbb{Z}[\pi_1(P)])$ which is trivial if and only if P has finite homotopy type. (Here $\mathbb{Z}[\pi_1(P)]$ denotes the integral group ring corresponding to $\pi_1(P)$. In the literature, $\tilde{K}_0(\mathbb{Z}[G])$ is sometimes abbreviated to $\tilde{K}_0(G)$.) As one of the necessary and sufficient conditions for completability of a 1-ended inward tame open manifold M^m ($m > 5$) with stable pro- π_1 , Siebenmann defined the *end obstruction* $\sigma_\infty(M^m)$, to be (up to sign) the finiteness obstruction $\sigma(N)$ of an arbitrary clean neighborhood of infinity N whose fundamental group “matches” the stable pro- $\pi_1(\varepsilon(M^m))$.²

In cases where M^m is multi-ended or has non-stable pro- π_1 (or both), a more general definition of $\sigma_\infty(M^m)$, introduced in [CS76], is required. Its definition employs several ideas from [Sie65, §6]. First note that there is a covariant functor \tilde{K}_0 from groups to abelian groups taking G to $\tilde{K}_0(\mathbb{Z}[G])$, which may be composed with the π_1 -functor to get a functor from path connected spaces to abelian groups; here we use an observation by Siebenmann allowing base points to be ignored. Next

²The main theorem of [O’B83], which contains [Sie65] as a special case, incorrectly uses $\sigma(M^m)$ —the finiteness obstruction of the entire manifold M^m — in place of $\sigma_\infty(M^m)$. We use the subscripted “ ∞ ” to distinguish the two. Siebenmann originally used the notation $\sigma(\varepsilon)$.

extend the functor and the finiteness obstruction to non-path-connected P (abusing notation slightly) by letting

$$\tilde{K}_0(\mathbb{Z}[\pi_1(P)]) = \bigoplus \tilde{K}_0(\mathbb{Z}[\pi_1(P^j)])$$

where $\{P^j\}$ is the set of path components of P , and letting

$$\sigma(P) = (\sigma(P^1), \dots, \sigma(P^k))$$

recalling that P is finitely dominated and, hence, has finitely many components—each finitely dominated.

Now, for an inward tame locally finite polyhedron P (or more generally locally compact ANR), let $\{N_j\}$ be a nested cofinal sequence of closed polyhedral neighborhoods of infinity and define

$$\sigma_\infty(P) = (\sigma(N_1), \sigma(N_2), \sigma(N_3), \dots) \in \varprojlim \left\{ \tilde{K}_0[\mathbb{Z}[\pi_1(N_i)]] \right\}$$

The bonding maps of the target inverse sequence

$$\tilde{K}_0[\mathbb{Z}[\pi_1(N_1)]] \leftarrow \tilde{K}_0[\mathbb{Z}[\pi_1(N_2)]] \leftarrow \tilde{K}_0[\mathbb{Z}[\pi_1(N_3)]] \leftarrow \dots$$

are induced by inclusion, with the Sum Theorem for finiteness obstructions [Sie65, Th.6.5] assuring consistency. Clearly, $\sigma_\infty(P)$ vanishes if and only if each N_i has finite homotopy type; by another application of the Sum Theorem, this happens if and only if *every* closed polyhedral neighborhood of infinity has finite homotopy type.

Remark 6. Alternatively, we could define $\sigma_\infty(P)$ to lie in the inverse limit of the *inverse system* corresponding to all closed polyhedral neighborhoods of infinity, partially ordered by inclusion. These inverse limits are isomorphic, and in either case, the combination of Conditions (a) and (c) of Theorem 1.0.1 is equivalent to the requirement that all clean neighborhoods of infinity have finite homotopy type—a property referred to as absolute inward tameness in [Gui16].

We close this section with an observation that builds upon Lemma 1.4.3. Both play key roles in the proof of Theorem 1.0.1.

Lemma 1.5.1. *Let M^m be a manifold and A a clean codimension 0 submanifold of ∂M^m . If M^m is inward tame and $\sigma_\infty(M^m)$ vanishes, then $M^m \setminus A$ is inward tame and $\sigma_\infty(M^m \setminus A)$ also vanishes.*

Proof. Lemma 1.4.3 assures us that if M^m is inward tame, then so too is $M^m \setminus A$. The latter ensures that $\sigma_\infty(M^m \setminus A)$ is defined. Arguing as we did in the proof of Lemma 1.4.3, $M^m \setminus A$ contains arbitrarily small neighborhoods of infinity which are homotopy equivalent to $A \cup N$, where N is a clean neighborhood of infinity in M^m . If $\sigma_\infty(M^m) = 0$, then N has finite homotopy type; and since $A \cup N = \overline{A \setminus N} \cup N$, where $\overline{A \setminus N}$ is a compact $(m - 1)$ -manifold, then $A \cup N$ has finite homotopy type (by a direct argument or easy application of the Sum Theorem for the finiteness obstruction). The vanishing of $\sigma_\infty(M^m \setminus A)$ then follows from the above discussion. \square

1.6 The τ_∞ -obstruction

The τ_∞ obstruction in Condition (d) of Theorem 1.0.1 was first defined in [CS76] and applied to Hilbert cube manifolds; the role it plays here is similar. It lies in the derived limit of an inverse sequence of Whitehead groups. For a more detailed discussion, the reader should see [CS76].

The *derived limit* of an inverse sequence

$$G_0 \xleftarrow{\lambda_1} G_1 \xleftarrow{\lambda_2} G_2 \xleftarrow{\lambda_3} \dots$$

of abelian groups is the quotient group:

$$\varprojlim^1 \{G_i, \lambda_i\} = \left(\prod_{i=0}^{\infty} G_i \right) / \{(g_0 - \lambda_1 g_1, g_1 - \lambda_2 g_2, g_2 - \lambda_3 g_3, \dots) \mid g_i \in G_i\}$$

It is a standard fact that pro-isomorphic inverse sequences of abelian groups have isomorphic derived limits.

Suppose a manifold M^m contains a cofinal sequence $\{N_i\}$ of clean neighborhoods of infinity with the property that each inclusion $\text{Fr } N_i \hookrightarrow N_i$ is a homotopy equiv-

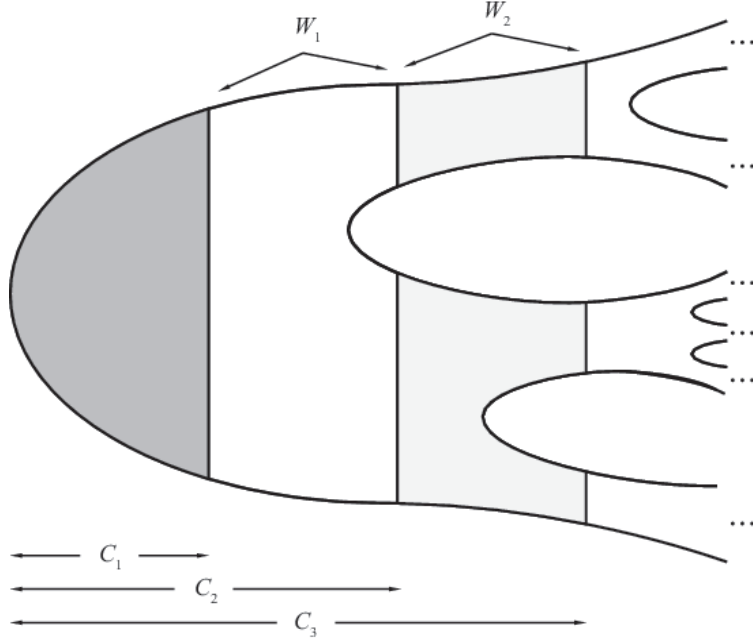

Figure 1.1: Decomposition of M^m into $\{W_i\}_{i=1}^{\infty}$.

alence³. Let $W_i = \overline{N_i \setminus N_{i+1}}$ and note that $\text{Fr } N_i \hookrightarrow W_i$ is a homotopy equivalence. See Figure 1.1.

Since $\text{Fr } N_i$ and W_i are finite polyhedra, the inclusion determines a Whitehead torsion $\tau(W_i, \text{Fr } N_i) \in \text{Wh}(\pi_1(\text{Fr } N_i))$ (see [Coh73]). As in the previous section, we must allow for non-connected $\text{Fr } N_i$ so we define

$$\text{Wh}(\pi_1(\text{Fr } N_i)) = \bigoplus \text{Wh}(\pi_1(\text{Fr } N_i^j))$$

where $\{\text{Fr } N_i^j\}$ is the (finite) set of components of $\text{Fr } N_i$ and

$$\tau(W_i, \text{Fr } N_i) = (\tau(W_i^1, \text{Fr } N_i^1), \dots, \tau(W_i^k, \text{Fr } N_i^k)).$$

These groups fit into an inverse sequence of abelian groups

$$\text{Wh}(\pi_1(N_1)) \leftarrow \text{Wh}(\pi_1(N_2)) \leftarrow \text{Wh}(\pi_1(N_3)) \leftarrow \dots$$

³A manifold admitting such sequence of neighborhoods of infinity is called *pseudo-collarable*. See [Gui00], [GT03] and [GT06] for discussion of that topic.

where the bonding homomorphisms are induced by inclusions. (To match [CS76], we have substituted $\pi_1(N_i)$ for the canonically equivalent $\pi_1(\text{Fr } N_i)$.) Let $\tau_i = \tau(W_i, \text{Fr } N_i) \in \text{Wh}(\pi_1(N_i))$. Then

$$\tau_\infty(M^m) = [(\tau_1, \tau_2, \tau_3, \dots)] \in \varprojlim^1 \{\text{Wh}(\pi_1(N_i))\}$$

where $[(\tau_1, \tau_2, \tau_3, \dots)]$ is the coset containing $(\tau_1, \tau_2, \tau_3, \dots)$.

If $\tau_\infty(M^m)$ is trivial, it is possible to adjust the choices of the N_i so that each inclusion $\text{Fr } N_i \hookrightarrow W_i$ has trivial torsion, and hence is a simple homotopy equivalence. Roughly speaking, the adjustment involves “lending and borrowing torsion to and from immediate neighbors of the W_i ”. The procedure is as described in [CS76, §6], except that a Splitting Theorem for finite-dimensional manifolds (see [O’B83, p.318]) replaces [CS76, Lemma 6.1]. The reader is warned that the procedure described in [O’B83, §4] is flawed; we recommend [CS76].

1.7 Geometric characterization of completable manifolds and a review of h- and s-cobordisms

The following geometric characterization of completable manifolds, which has analogs in [Tuc74] and [O’B83], paves the way for the proof of Theorem 1.0.1. It leads naturally to the consideration of h- and s-cobordisms, which we will briefly review for later use.

Lemma 1.7.1 (Geometric characterization of completable manifolds). *A non-compact manifold with boundary M^m is completable iff $M^m = \cup_{i=1}^\infty C_i$ where, for all i :*

- (i) C_i is a compact clean codimension 0 submanifold of M^m ,
- (ii) $C_i \subset \text{Int } C_{i+1}$, and
- (iii) if W_i denotes $\overline{C_{i+1} \setminus C_i}$, then $(W_i, \text{Fr } C_i) \approx (\text{Fr } C_i \times [0, 1], \text{Fr } C_i \times \{0\})$.

Proof. For the forward implication, suppose \widehat{M}^m is a compact manifold, A is closed subset set of $\partial \widehat{M}^m$, and $M^m = \widehat{M}^m \setminus A$. Write A as $\cap_i F_i$, where $\{F_i\}_{i=1}^\infty$ is a

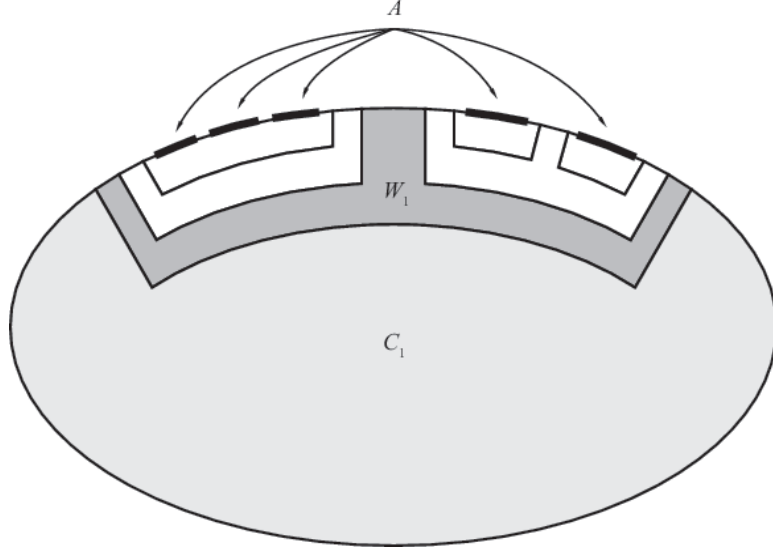

Figure 1.2: Decomposing completed M^m into product cobordisms.

sequence of compact clean codimension 0 submanifolds of $\partial\widehat{M}^m$ with $F_{i+1} \subseteq \text{Int } F_i$. Let $c : \partial\widehat{M}^m \times [0, 1] \rightarrow \widehat{M}^m$ be a collar on $\partial\widehat{M}^m$ with $c(\partial\widehat{M}^m \times \{0\}) = \partial\widehat{M}^m$ and, for each i , let $C_i = \widehat{M}^m \setminus c(\text{Int}(F_i) \times [0, 1/i])$. Assertions (i) and (ii) are clear. Moreover,

$$\begin{aligned} W_i &\approx F_i \times [0, 1/i] \setminus (\text{Int } F_{i+1} \times [0, 1/(i+1)]) \\ &\approx F_i \times [0, 1/i] \end{aligned}$$

via a homeomorphism taking $c(F_i \times \{1/i\})$ onto $F_i \times \{1/i\}$. Then, since $\text{Fr } C_i = c(F_i \times \{1/i\} \cup \partial F_i \times [0, 1/i]) \approx F_i$, an application of relative regular neighborhood theory allows an adjustment of that homeomorphism so that $\text{Fr } C_i$ is taken onto $F_i \times \{1/i\}$. A reparametrization of the closed interval completes the proof of assertion (iii). (Note that this works even when the F_i have multiple and varying numbers of components. See Figure 1.2.)

For the converse, we reverse the above procedure to embed M^m in a copy of C_1 . Details can be found in [Tuc74, Lemma 1]. \square

The above lemma shows that a strategy for completing a manifold is to fill up a

neighborhood of infinity in M^m with a sequence of cobordisms, then modify those cobordisms (when possible) so they become products.

Recall that an (absolute) *cobordism* is a triple (W, A, B) , where W is a manifold with boundary and A and B are disjoint manifolds without boundary for which $A \cup B = \partial W$. The triple (W, A, B) is a *relative cobordism* if A and B are disjoint codimension 0 clean submanifolds of ∂W . In that case, there is an associated absolute cobordism $(V, \partial A, \partial B)$ where $V = \partial W \setminus (\text{int } A \cup \text{int } B)$. We view absolute cobordisms as special cases of relative cobordisms where $V = \emptyset$. A relative cobordism is an *h-cobordism* if each of the inclusions $A \hookrightarrow W$, $B \hookrightarrow W$, $\partial A \hookrightarrow V$, and $\partial B \hookrightarrow V$ is a homotopy equivalence; it is an *s-cobordism* if each of these inclusions is a simple homotopy equivalence. (For convenience, $\emptyset \hookrightarrow \emptyset$ is considered a simple homotopy equivalence.) A relative cobordism is *nice* if it is absolute or if $(V, \partial A, \partial B) \approx (\partial A \times [0, 1], \partial A \times \{0\}, \partial A \times \{1\})$. The crucial result, proof (and additional discussion) of which may be found in [RS82], is the following.

Theorem 1.7.2 (Relative s-cobordism Theorem). *A compact nice relative cobordism (W, A, B) with $\dim W \geq 6$ is a product, i.e., $(W, A, B) \approx (A \times [0, 1], A \times \{0\}, A \times \{1\})$, if and only if it is an s-cobordism.*

Remark 7. A situation similar to a nice relative cobordism occurs when $\partial W = A \cup B'$, where A and B' are codimension 0 clean submanifolds of ∂W with a common nonempty boundary $\partial A = \partial B'$. We call such cobordism a *precobordism*. By choosing a clean codimension 0 submanifold $B \subseteq B'$ with the property that $B' \setminus \text{int } B \approx \partial B \times [0, 1]$ we arrive at a nice relative cobordism (W, A, B) . When this procedure is applied, we will refer to (W, A, B) as a corresponding *nice relative cobordism*. For notational consistency, we will always adjust the term B' on the far right of the triple (W, A, B') , leaving A alone. A precobordism is a *one-sided h-precobordism* if one of the pairs of inclusions $A \hookrightarrow W$ or $B' \hookrightarrow W$ is a homotopy equivalence.

For our purposes, the following lemma will be crucial.

Lemma 1.7.3. *Let W be a compact manifold with $\partial W = A \cup B'$, where A and B' are codimension 0 clean submanifolds of ∂W with a common boundary. Suppose*

$A \hookrightarrow W$ is a homotopy equivalence and that there is a homotopy $J : W \times [0, 1] \rightarrow W$ such that $J_0 = \text{id}_W$, J is fixed on $\partial B'$, and $J_1(W) \subseteq B'$. Then $B' \hookrightarrow W$ is a homotopy equivalence, so the corresponding nice relative cobordism (W, A, B) is an h -cobordism.

Proof. Choose $p \in \partial A = \partial B'$, to be used as the basepoint for A , B' and W . Let $i : A \hookrightarrow W$ and $\iota : B' \hookrightarrow W$ denote inclusions and define $f : A \rightarrow B'$ by $f(x) = J_1(x)$. Then

$$\iota \circ f = J_1 \circ i \tag{1.7.1}$$

Clearly $J_1 : W \rightarrow W$ induces the identity isomorphism on $\pi_1(W, p)$, and since i is a homotopy equivalence, it induces a π_1 -isomorphism. So, from (1.7.1), we may deduce that $f_* : \pi_1(A, p) \rightarrow \pi_1(B', p)$ is injective. Moreover, since f restricts to the identity function mapping ∂A onto $\partial B'$, [Eps66] allows us to conclude that f_* is an isomorphism. From there it follows that $\iota_* : \pi_1(B', p) \rightarrow \pi_1(W, p)$ is also an isomorphism.

Let $p : \widetilde{W} \rightarrow W$ be the universal covering projection, $\widetilde{A} = p^{-1}(A)$, and $\widetilde{B}' = p^{-1}(B')$. Since i_* and ι_* are both π_1 -isomorphisms these are the universal covers of A and B' , respectively. By generalized Poincaré duality for non-compact manifolds,

$$H_k(\widetilde{W}, \widetilde{B}'; \mathbb{Z}) \cong H_c^{n-k}(\widetilde{W}, \widetilde{A}; \mathbb{Z}),$$

where cohomology is with compact supports. Since $\widetilde{A} \hookrightarrow \widetilde{W}$ is a proper homotopy equivalence, all of these relative cohomology groups vanish, so $H_k(\widetilde{W}, \widetilde{B}'; \mathbb{Z}) = 0$ for all k . By the relative Hurewicz theorem, $\pi_k(\widetilde{W}, \widetilde{B}') = 0$ for all k , so the same is true for $\pi_k(W, B')$. An application of Whitehead's theorem allows us to conclude that $B' \hookrightarrow W$ is a homotopy equivalence. \square

1.8 Proof of the Manifold Completion Theorem: necessity

We will prove necessity of the conditions in Theorem 1.0.1 by a straightforward application of Lemma 1.7.1.

Proof of Theorem 1.0.1 (necessity). Suppose \widehat{M}^m is a compact manifold and A is closed subset set of $\partial\widehat{M}^m$ such that $M^m = \widehat{M}^m \setminus A$. As in the proof of Lemma 1.7.1 write $A = \bigcap_i F_i$, where $\{F_i\}$ is a sequence of compact clean codimension 0 submanifolds of $\partial\widehat{M}^m$ with $F_{i+1} \subseteq \text{Int } F_i$, and let $c : \partial\widehat{M}^m \times [0, 1] \rightarrow \widehat{M}^m$ be a collar on $\partial\widehat{M}^m$ with $c(\partial\widehat{M}^m \times \{0\}) = \partial\widehat{M}^m$. For each i , let $\widehat{N}_i = c(F_i \times [0, 1/i])$ and $N_i = \widehat{N}_i \setminus A$. Then $\{N_i\}$ is cofinal sequence of clean neighborhoods of infinity in M^m with $\text{Fr } N_i = c(F_i \times \{1/i\} \cup \partial F_i \times [0, 1/i])$. Since $F_i \times \{1/i\} \cup \partial F_i \times [0, 1/i] \hookrightarrow F_i \times [0, 1/i]$ and $N_i \hookrightarrow \widehat{N}_i$ are both homotopy equivalences, then so is $\text{Fr } N_i \hookrightarrow N_i$; and since each N_i has finite homotopy type, conditions (a) and (c) of Theorem 1.0.1 both hold (by the discussion in §1.4 and 1.5).

If we let $W_i = \overline{N_i \setminus N_{i+1}}$, then $\tau_\infty(M^m)$ is determined by the Whitehead torsions of inclusions $\text{Fr } N_i \hookrightarrow W_i$ (see §1.6). Associate W_i with $F_i \times [0, 1/i]$ and $\text{Fr } N_i$ with $F_i \times \{1/i\} \cup \partial F_i \times [0, 1/i]$, as in the proof of Lemma 1.7.1. Then, the fact that both $F_i \times \{1/i\} \hookrightarrow F_i \times [0, 1/i]$ and $F_i \times \{1/i\} \hookrightarrow F_i \times \{1/i\} \cup \partial F_i \times [0, 1/i]$ are simple homotopy equivalences ensures that $\tau(W_i, \text{Fr } N_i) = 0$. So condition (d) is satisfied.

It remains to verify the peripheral π_1 -stability condition. Fix $i \geq 1$ and let F_i^j be one component of F_i , $\widehat{N}_i^j = c(F_i^j \times [0, 1/i])$ and $N_i^j = \widehat{N}_i^j \setminus A$. Then $\partial_M N_i^j = c(F_i^j \times \{0\}) \setminus A$ and N_i^j is clearly $\partial_M N_i^j$ -connected at infinity. For each $k > i$, let F'_k be the union of all components of F_k contained in F_i^j , $\widehat{N}'_k = c(F'_k \times [0, 1/k])$ and $N'_k = \widehat{N}'_k \setminus A$. By definition, we may consider the sequence

$$\pi_1(\partial_M N_i^j \cup N'_{i+1}) \xleftarrow{\mu_2} \pi_1(\partial_M N_i^j \cup N'_{i+2}) \xleftarrow{\mu_3} \pi_1(\partial_M N_i^j \cup N'_{i+3}) \xleftarrow{\mu_4} \dots \quad (1.8.1)$$

where basepoints are suppressed and bonding homomorphisms are compositions of maps induced by inclusions and change-of-basepoint isomorphisms. Each of those inclusions is the top row of a commutative diagram

$$\begin{array}{ccc} \partial_M N_i^j \cup N'_k & \hookrightarrow & \partial_M N_i^j \cup N'_{k+1} \\ \downarrow \text{incl} & & \downarrow \text{incl} \\ \partial_M N_i^j \cup \widehat{N}'_k & & \partial_M N_i^j \cup \widehat{N}'_{k+1} \\ \downarrow \approx & & \downarrow \approx \\ (F_i^j \times \{0\}) \cup (F'_k \times [0, 1/k]) & \hookrightarrow & (F_i^j \times \{0\}) \cup (F'_{k+1} \times [0, 1/k+1]) \end{array}$$

where the bottom row is an obvious homotopy equivalence, as are all vertical maps.

It follows that the initial inclusion is a homotopy equivalence as well. As a result, all bonding homomorphisms in (1.8.1) are isomorphisms, so the sequence is stable. \square

1.9 Proof of the Manifold Completion Theorem: sufficiency

Throughout this section $\{C_i\}_{i=1}^\infty$ will denote a clean compact exhaustion of M^m with a corresponding cofinal sequence of clean 0-neighborhoods of infinity $\{N_i\}_{i=1}^\infty$, each of which has a finite set of connected components $\{N_i^j\}_{j=1}^{k_i}$. For each i we will let $W_i = \overline{N_i \setminus N_{i+1}}$, a compact clean codimension 0 submanifold of M^m . Note that ∂W_i may be expressed as $\text{Fr } N_i \cup (\partial_M W_i \cup \text{Fr } N_{i+1})$, a union of two clean codimension 0 submanifolds of ∂W_i intersecting in a common boundary $\partial(\text{Fr } N_i)$. (Figures 1.2 and 1.1 contain useful schematics.) The proof of Theorem 1.0.1 will be accomplished by gradually improving the exhaustion of M^m so that ultimately, conditions (i)-(iii) of Lemma 1.7.1 are all satisfied.

Lemma 1.9.1. *If M^m is inward tame and $\sigma_\infty(M^m)$ vanishes, then for each i , $\sigma(N_i)$ and $\sigma(N_i \setminus \partial M^m)$ are both zero.*

Proof. By our discussion in §1.5, if M^m is inward tame and $\sigma_\infty(M^m) = 0$, then each N_i has finite homotopy type. Since $N_i \hookrightarrow N_i \setminus \partial M^m$ is a homotopy equivalence, so does $N_i \setminus \partial M^m$. \square

Proposition 1.9.2. *If M^m satisfies Conditions (a)-(c) of Theorem 1.0.1 then the $\{C_i\}$ and the corresponding $\{N_i\}$ can be chosen so that, for each i ,*

1. $\text{Fr } N_i \hookrightarrow N_i$ is a homotopy equivalence, and
2. $\partial_M W_i \cup \text{Fr } N_{i+1} \hookrightarrow N_i$ is a homotopy equivalence; therefore,
3. the nice relative cobordisms corresponding to $(W_i, \text{Fr } N_i, \partial_M W_i \cup \text{Fr } N_{i+1})$ are h -cobordisms.

Proof. By Lemma 1.9.1 and the definition of peripheral π_1 -stability at infinity, we can begin with a clean compact exhaustion $\{C_i\}_{i=1}^\infty$ of M^m and a corresponding sequence of neighborhoods of infinity $\{N_i\}_{i=1}^\infty$, each with a finite set of connected components $\{N_i^j\}_{j=1}^{k_i}$, so that for all $i \geq 1$ and $1 \leq j \leq k_i$,

- i) N_i^j is inward tame,
- ii) N_i^j is $(\partial_M N_i^j)$ -connected and $(\partial_M N_i^j)$ - π_1 -stable at infinity, and
- iii) $\sigma_\infty(N_i^j) = 0$.

By Lemmas 1.4.3, 1.3.3, and 1.5.1, this implies that

- i') $N_i^j \setminus \partial_M N_i^j$ is inward tame,
- ii') $N_i^j \setminus \partial M^m$ is 1-ended and has stable fundamental group at infinity, and
- iii') $\sigma_\infty(N_i^j \setminus \partial M^m) = 0$.

These are precisely the hypotheses of Siebenmann's Relativized Main Theorem ([Sie65, Th.10.1]), so $N_i^j \setminus \partial M^m$ contains an open collar neighborhood of infinity $V_i^j \approx \partial V_i^j \times [0, \infty)$. Following the proof in [Sie65] (similar to what is done in [O'B83, Th.3.2]), this can be done so that $\partial N_i^j \setminus \partial M^m (= \text{int}(\text{Fr } N_i^j))$ and ∂V_i^j contain clean compact codimension 0 submanifolds A_i^j and B_i^j , respectively, so that $(\partial N_i^j \setminus \partial M^m) \setminus \text{int } A_i^j = \partial V_i^j \setminus \text{int } B_i^j \approx \partial A_i^j \times [0, 1)$. See Figure 1.3.

Then $K_i^j = \overline{N_i^j \setminus V_i^j}$ is a clean codimension 0 submanifold of M^m which intersects C_i in A_i^j . To save on notation, replace C_i with $C_i \cup (\cup K_i^j)$, which is still a clean compact codimension 0 submanifold of M^m , but with the added property that

$$N_i \setminus \partial M^m \approx \text{int}(\text{Fr } N_i) \times [0, \infty). \quad (1.9.1)$$

Since adding $\partial_M N_i$ back in does not affect homotopy types, we also have that

$$\text{Fr } N_i \hookrightarrow N_i \text{ is a homotopy equivalence.} \quad (1.9.2)$$

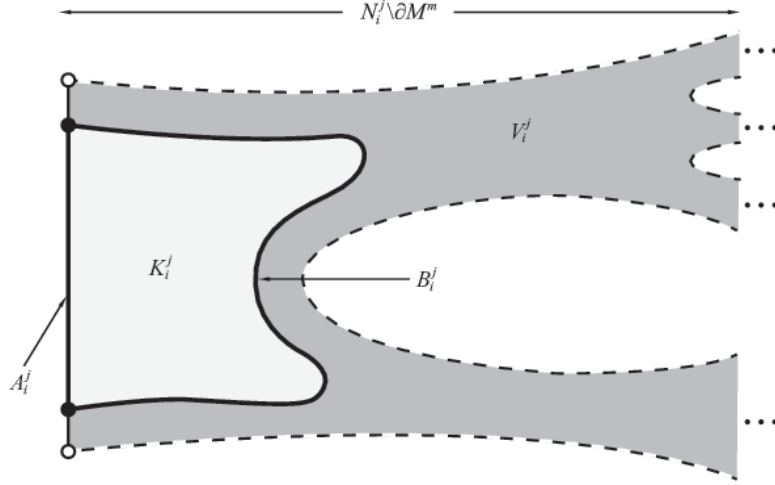

Figure 1.3: $V_i^j \approx \partial V_i^j \times [0, 1)$ contained in $N_i^j \setminus \partial M^m$.

Having enlarged the C_i , pass to a subsequence if necessary to regain the property that $C_i \subseteq \text{Int } C_{i+1}$ for all i .

Letting $N_i = \overline{M^m \setminus C_i}$ gives a nested cofinal sequence of clean neighborhoods of infinity $\{N_i\}$ with the property that each inclusion $\text{Fr } N_i \hookrightarrow N_i$ is a homotopy equivalence; in other words, we have obtained a pseudo-collar structure on M^m . For each $i \geq 1$, let $W_i = \overline{N_i \setminus N_{i+1}}$, a clean compact codimension 0 submanifold of M^m with $\partial W_i = \text{Fr } N_i \cup (\partial_M W_i \cup \text{Fr } N_{i+1})$.

CLAIM 1. $\text{Fr } N_i \hookrightarrow W_i$ is a homotopy equivalence.

Condition (1.9.2) applied to N_i ensures the existence a strong deformation retraction H_t of N_i onto $\text{Fr } N_i$. That same condition applied to N_{i+1} ensures the existence of a retraction $r : N_{i+1} \rightarrow \text{Fr } N_{i+1}$, which extends to a retraction $\hat{r} : N_i \rightarrow W_i$. The composition $\hat{r}H_t$, restricted to W_i , gives a deformation retraction of W_i onto $\text{Fr } N_i$.

CLAIM 2. $\partial_M W_i \cup \text{Fr } N_{i+1} \hookrightarrow W_i$ is a homotopy equivalence.

By applying Lemma 1.7.3, it is enough to show that there exists a homotopy $H : W_i \times [0, 1] \rightarrow W_i$, fixed on $\partial(\text{Fr } N_i)$, with the property that $H_1(W_i) \subseteq \partial_M W_i \cup \text{Fr } N_{i+1}$. Toward that end, let B be a collar neighborhood of $\partial_M W_i$ in W_i and let $D = \overline{W_i \setminus B}$. Use the collar structure on $N_i \setminus \partial M^m$ to obtain a homotopy $K :$

$N_i \times [0, 1] \rightarrow N_i$, fixed on $\partial(\text{Fr } N_i)$, which pushes N_i into the complement of D ; in other words $K_1(N_i) \subseteq B \cup N_{i+1}$. Compose this homotopy with the retraction $\hat{r} : N_i \rightarrow W_i$ used in the previous claim to get a homotopy $\hat{r}K_t$ of W_i (still fixed on $\partial(\text{Fr } N_i)$) with $\hat{r}K_1(W_i) \subseteq B \cup \text{Fr } N_{i+1}$. Follow this with a homotopy that deformation retracts B onto $\partial_M W_i$ while sending $\text{Fr } N_{i+1}$ into itself to complete the desired homotopy and prove Claim 2.

We can now write $M^m = C_1 \cup W_1 \cup W_2 \cup W_3 \cup \dots$ where, for each i ,

- W_i is a compact clean codimension 0 submanifold of M^m ,
- $\partial W_i = \text{Fr } N_i \cup (\partial_M W_i \cup \text{Fr } N_{i+1})$, and
- both $\text{Fr } N_i \hookrightarrow W_i$ and $\partial_M W_i \cup \text{Fr } N_{i+1} \hookrightarrow W_i$ are homotopy equivalences.

As such, the corresponding nice relative cobordisms (as described in Remark 7) are h-cobordisms. □

Proposition 1.9.3. *If M^m satisfies Conditions (b)-(d) of Theorem 1.0.1 the conclusion of Proposition 1.9.2 can be improved so that, for each i , the nice relative cobordisms corresponding to $(W_i, \text{Fr } N_i, \partial_M W_i \cup \text{Fr } N_{i+1})$ are s-cobordisms. In that case, $(W_i, \text{Fr } N_i) \approx (\text{Fr } N_i \times [0, 1], \text{Fr } N_i \times \{0\})$ for all i , and M^m is completable.*

Proof. By the triviality of $\tau_\infty(M^m)$, it is possible to adjust the choices of the N_i so that each inclusion $\text{Fr } N_i \hookrightarrow W_i$ has trivial Whitehead torsion, i.e., $\tau(W_i, \text{Fr } N_i) = 0$, and hence is a simple homotopy equivalence. As was discussed in §1.6, the adjustment involves “lending and borrowing torsion to and from immediate neighbors of the W_i ” as described in [CS76, §6], except that a Splitting Theorem for finite-dimensional manifolds (see [O’B83, p.318]) replaces [CS76, Lemma 6.1].

To complete the proof, apply the Relative s-cobordism Theorem to each W_i then apply Lemma 1.7.1. □

1.10 \mathcal{Z} -compactifications and the proof of Theorem 1.0.2

In this section we prove Theorem 1.0.2. Since $M^m \times [0, 1]$ satisfies Conditions (a), (c) and (d) of Theorem 1.0.1 if and only if M^m satisfies those same conditions (see [CS76]), it suffices to prove the following proposition which is based on work found in [Gui07].

Proposition 1.10.1. *If a manifold M^m is inward tame at infinity, then $M^m \times [0, 1]$ is peripherally π_1 -stable at infinity.*

Proof. Apply Corollary 1.4.5 to obtain a cofinal sequence $\{N_i\}$ of clean neighborhoods of infinity for M^m with the property that, for all i , each component N_i^j of N_i is $\partial_M N_i^j$ -connected at infinity. Since $\{N_i \times [0, 1]\}$ is a cofinal sequence of clean neighborhoods of infinity for $M^m \times [0, 1]$ it suffices to show that the corresponding connected components, $N_i^j \times [0, 1]$, are all $\partial_{M \times [0, 1]}(N_i^j \times [0, 1])$ -connected and $(\partial_{M \times [0, 1]}(N_i^j \times [0, 1]))$ - π_1 -stable at infinity. By Lemmas 1.3.2 and 1.3.3, that is equivalent to showing that, for each N_i^j , $\text{int}_M(N_i^j) \times (0, 1)$ is 1-ended and has stable pro- π_1 at that end. Every connected topological spaces becomes 1-ended upon crossing with $(0, 1)$, so that condition is immediate. The π_1 -stability property is proved with a small variation on the main technical argument from [Gui07]; in particular, Corollary 3.6 from that paper. The “small variation” is necessary because the earlier argument assumed the product of an *open* manifold with $(0, 1)$. That issue is easily overcome by arranging that the analog of homotopy K_t used in [Gui07, Prop.3.3] sends the manifold interior of $\text{Int}_M(N_i^j)$ into itself and sends $\text{Fr } N_i^j$ into itself for all t . That is easily accomplished since $\text{Fr } N_i^j$ has an open collar neighborhood at infinity. \square

1.11 A counterexample to a question of O’Brien

We now give a negative answer to a question posed by O’Brien [O’B83, p.308].

Question. *(For a 1-ended manifold M^m with 1-ended boundary), let $\{V_i\}$ be a*

cofinal sequence of clean 0-neighborhoods of infinity. If $\{\pi_1(\partial M^m \cup V_i)\}_{i \geq 1}$ is stable, does it follow that M^m is peripherally π_1 -stable at infinity?

The key ingredient in our counterexamples is a collection of contractible open n -manifolds W^n (one for each $n \geq 3$), constructed by R. Sternfeld in his dissertation [Ste77]⁴. Each W^n has the property that it cannot be embedded in any compact n -manifold. Although these W^n have finite homotopy type, they are not inward tame, since they contain arbitrarily small clean connected neighborhoods of infinity with non-finitely generated fundamental groups. Our counterexamples will be the $(n + 1)$ -manifolds $W^n \times [0, 1)$. First a general observation.

Proposition 1.11.1. *Let W^n be a connected open n -manifold. If W^n has finite homotopy type, then $W^n \times [0, 1)$ is 1-ended and inward tame, with $\sigma_\infty(W^n \times [0, 1)) = 0$.*

Proof. It suffices to exhibit arbitrarily small connected clean neighborhood of infinity in W^n with finite homotopy type. Let $N \subseteq W^n$ be a clean neighborhood of infinity and $a \in (0, 1)$. By choosing N small and a close to 1, we can obtain arbitrarily small neighborhoods of infinity in $W^n \times [0, 1)$ of the form

$$V(N, a) = (N \times [0, 1)) \cup (W^n \times [a, 1)).$$

Since $V(N, a)$ deformation retracts onto $W^n \times \{a\}$, it is connected and has finite homotopy type. □

Example 2. Consider the $(n + 1)$ -manifold $M^{n+1} = W^n \times [0, 1)$, where W^n is the Sternfeld n -manifold ($n \geq 3$) described above. Then $\partial M^{n+1} = W^n \times \{0\}$. A standard duality argument shows that *every* contractible open manifold of dimension ≥ 2 is 1-ended. Let $\{N_i\}$ be a cofinal sequence of clean connected neighborhoods of infinity in W^n , and for each $i \geq 1$, let $V_i = V(N_i, \frac{i}{i+1})$, as defined in the previous proof. By Seifert-van Kampen, each $V_i \cup \partial M^{n+1}$ is simply connected, so the inverse sequence $\{\pi_1(\partial M^{n+1} \cup V_i)\}_{i \geq 1}$ is pro-trivial, hence, stable.

⁴There is an error in Sternfeld's dissertation, which is fixed in [Gu18].

To see that M^{n+1} is not peripherally π_1 -stable at infinity, first assume that $n \geq 5$. Then, if M^{n+1} were peripherally π_1 -stable at infinity, it would be completable by Theorem 1.0.1. (The triviality of $\tau_\infty(M^{n+1})$ is immediate since M^{n+1} is simply connected at infinity, which follows from the simple connectivity of the V_i .) But, if \widehat{M}^{n+1} were a completion, then $W^n \times \{0\} \hookrightarrow \partial\widehat{M}^{n+1}$ would be an embedding into a closed n -manifold, contradicting Sternfeld’s theorem.

To obtain analogous examples when $n = 3$ or $n = 4$, we cannot rely on the Manifold Completion Theorem. But a direct analysis of the fundamental group calculations in Sternfeld’s proof reveals that the peripheral pro- π_1 -systems arising in $W^n \times [0, 1)$ are nonstable in those dimensions as well.

1.12 Proof of Lemma 1.3.7

We now return to Lemma 1.3.7, which asserts that the two natural candidates for the definition of “peripherally π_1 -stable at infinity” (the global versus the local approach) are equivalent for inward tame manifolds. The intuition behind the lemma is fairly simple. If M^m contains arbitrarily small 0-neighborhoods of infinity N with the property that each component N^j is $\partial_M N^j$ - π_1 -stable at infinity, then those components provide arbitrarily small neighborhoods of the ends satisfying the necessary π_1 -stability condition. Conversely, if each end ε has arbitrarily small strong 0-neighborhoods P that are $\partial_M P$ - π_1 -stable at infinity, we can use the compactness of the set of ends (in the Freudenthal compactification) to find, within any neighborhood of infinity, a finite collection $\{P_1, \dots, P_k\}$ of such neighborhoods which cover the end of M^m . If we can do this so the P_i are pairwise disjoint, we are finished—just let $N = \cup P_i$. That is not as easy as one might hope, but we are able to attain the desired conclusion by proving the following proposition.

Proposition 1.12.1. *Suppose M^m is inward tame and each end ε has arbitrarily small strong 0-neighborhoods P_ε that are $\partial_M P_\varepsilon$ - π_1 -stable at infinity. Then every strong partial 0-neighborhood of infinity $Q \subseteq M^m$ is $\partial_M Q$ - π_1 -stable at infinity.*

Our proof requires that we break the stability condition into a pair of weaker conditions. An inverse sequence of groups is:

- *semistable* (sometimes called *pro-epimorphic*) if it is pro-isomorphic to an inverse sequence of surjective homomorphisms;
- *pro-monomorphic* if it is pro-isomorphic to an inverse sequence of injective homomorphisms.

It is an elementary fact that an inverse sequence is stable if and only if it is both semistable and pro-monomorphic.

We will make use of the following topological characterizations of the above properties, when applied to $\text{pro-}\pi_1$. In these theorems, a “space” should be locally compact, locally connected, and metrizable.

Proposition 1.12.2. *Let X be a 1-ended space and $r : [0, \infty) \rightarrow X$ a proper ray. Then $\text{pro-}\pi_1(X, r)$ is*

1. *semistable if and only if, for every compact set $C \subseteq X$, there exists a larger compact set $D \subseteq X$ such that for any compact set E with $D \subseteq E \subseteq X$, every loop in $X \setminus D$ with base point on r can be pushed into $X \setminus E$ by a homotopy with image in $X \setminus C$ keeping the base point on r , and*
2. *pro-monomorphic if and only if X contains a compact set C with the property that, for every compact set D with $C \subseteq D \subseteq X$, there exists a compact set $E \supseteq D$ with the property that every loop in $X \setminus E$ that contracts in $X \setminus C$ also contracts in $X \setminus D$.*

These are standard. See, for example [Geo08] or [Gui16]. In the case that $\text{pro-}\pi_1(X, r)$ is pro-monomorphic, the compact set C in the above proposition is called a π_1 -core for X . Notice that, by Proposition 1.12.2, the property of (1-ended) X having pro-monomorphic $\text{pro-}\pi_1(X, r)$ is independent of the choice of r .

It is a non-obvious (but standard) fact that having semistable $\text{pro-}\pi_1(X, r)$ is also independent of the choice of r . As for the characterization of semistable $\text{pro-}\pi_1(X, r)$, we are mostly interested in the following easy corollary.

Corollary 1.12.3. *If X is a 1-ended space and $\text{pro-}\pi_1(X, r)$ is semistable for some (hence every) proper ray r , then for each compact set $C \subseteq X$, there is a larger compact set $D \subseteq X$ such that, for every compact set $E \subseteq X$ and every path $\lambda : [0, 1] \rightarrow X \setminus D$ with $\lambda(\{0, 1\}) \subseteq E$, there is a path homotopy in $X \setminus C$ taking λ to a path λ' in $X \setminus E$.*

We are now ready for our primary task.

Proof of Proposition 1.12.1. Let Q be a strong partial 0-neighborhood of infinity in M^m . By Lemma 1.3.3, proving that Q is $\partial_M Q$ - π_1 -stable at infinity is equivalent to proving that the 1-ended space $Q \setminus \partial M^m$ has stable $\text{pro-}\pi_1$. We will take the latter approach.

By Lemma 1.4.3 $Q \setminus \partial M^m$ is inward tame, so a modification of the argument in [GT03, Prop. 3.2] ensures that $\text{pro-}\pi_1(Q \setminus \partial M^m, r)$ is semistable. It is therefore enough to show that $\text{pro-}\pi_1(Q \setminus \partial M^m, r)$ is pro-monomorphic. We will do that by verifying the condition described in Proposition 1.12.2, i.e., we will show that $Q \setminus \partial M^m$ contains a π_1 -core.

By hypothesis, each end ε of Q has a strong 0-neighborhood P_ε which is $\partial_M P_\varepsilon$ - π_1 -stable at infinity and lies in $\text{Int}_M Q$. Since the set of ends of Q is compact in the Freudenthal compactification, there is a finite subcollection $\{P_{\varepsilon_i}\}_{i=1}^k$ whose union is a neighborhood of infinity in Q . Place the collection of submanifolds $\{P_{\varepsilon_i}\}_{i=1}^k$ in general position.

CLAIM 1. *For each $\Omega \subseteq \{1, \dots, k\}$ the set $\bigcap_{j \in \Omega} P_{\varepsilon_j}$ has finitely many components, each of which is a clean codimension 0 submanifold of M^m .*

General position ensures that each component is a clean codimension 0 submanifold of M^m . Since each P_{ε_j} is a closed subset of M^m each component T of $\bigcap_{j \in \Omega} P_{\varepsilon_j}$ is closed in M^m , and since T cannot also be open in M^m it must have nonempty frontier. Since $\{P_{\varepsilon_j}\}_{j \in \Omega}$ is in general position, so also is the collection of (compact) frontiers, $\{\text{Fr } P_{\varepsilon_j}\}_{j \in \Omega}$. So, for each $i \neq j$ in Ω , $\Delta_{i,j} = \text{Fr } P_{\varepsilon_i} \cap \text{Fr } P_{\varepsilon_j}$ is a clean codimension 1 submanifold of $\text{Fr } P_{\varepsilon_i}$ and $\text{Fr } P_{\varepsilon_j}$. The union of these $\Delta_{i,j}$ separate

$\cup_{j=1}^k \text{Fr } P_{\varepsilon_j}$ into finitely many pieces, and since the frontier of each T is a union of these pieces, there can only be finitely many such T .

Choose an embedding $b : \partial M^m \times [0, 1] \rightarrow M^m$ with $b(x, 0) = x$ for all $x \in \partial M^m$ and whose image B is a regular neighborhood of ∂M^m in M^m . With some additional care, arrange that B intersects: Q in $b(\partial_M Q \times [0, 1])$; each P_{ε_i} in $b(\partial_M P_{\varepsilon_i} \times [0, 1])$; and (more specifically) each component T of each finite intersection $\cap_{j \in \Omega} P_{\varepsilon_j}$ in $b(\partial_M T \times [0, 1])$. For each $0 \leq s < t \leq 1$, let $B^{[s,t]} = b(\partial M^m \times [s, t])$, $B^{(s,t)} = b(\partial M^m \times (s, t))$, etc. For $A \subseteq \partial M^m$, let $B_A = b(A \times [0, 1])$ and define $B_A^{[s,t]}$, $B_A^{(s,t)}$, etc. analogously.

By hypothesis and Proposition 1.12.2 we can choose a clean codimension 0 compact π_1 -core C_i for each $P_{\varepsilon_i} \setminus \partial M^m$. Then choose t so small that $B^{[0,t]} \cap (\cup_{i=1}^k C_i) = \emptyset$. Let $C'_0 \equiv \overline{Q \setminus \cup_{i=1}^k P_{\varepsilon_i}}$, then let $C_0 = C'_0 \setminus B^{[0,t]}$ so that C_0 is a compact clean codimension 0 submanifold of $Q \setminus \partial M^m$. Let $C = \cup_{i=0}^k C_i \subseteq Q \setminus \partial M^m$. Notice that the collection $\left\{ B_{\partial_M Q}^{[0,t]}, P_{\varepsilon_1}, \dots, P_{\varepsilon_k} \right\}$ covers $Q \setminus \text{Int}_Q C$.

Choose a clean codimension 0 compact submanifold of $D' \subseteq Q \setminus \partial M^m$ so large that

- i) $\text{Int}_Q D' \supseteq C$,
- ii) D' contains every compact component of $\cap_{j \in \Omega} P_{\varepsilon_j}$ for all $\Omega \subseteq \{1, \dots, k\}$, and
- iii) for any compact set $E \subseteq Q \setminus \partial M^m$ such that $D' \subseteq E$, if λ is a path in $T \setminus \partial M^m$, where T is an unbounded component of $P_{\varepsilon_i} \cap P_{\varepsilon_j}$ for some $i, j \in \{1, \dots, k\}$, and λ lies outside D' with endpoints outside E , then there is a path homotopy of λ in $(T \setminus \partial M^m) \setminus C$ pushing λ outside E . (This uses Corollary 1.12.3 and the fact that each T , being a clean partial neighborhood of infinity in M^m , has the property that $T \setminus \partial M^m$ has finitely many ends, each with semistable pro- π_1 .)

Now choose a compact set $D \subseteq Q \setminus \partial M^m$ such that

- i') $D \supseteq D'$,

ii') for every $\Omega \subseteq \{1, \dots, k\}$ and every unbounded component T of $\bigcap_{j \in \Omega} P_{\varepsilon_j}$, each $x \in (T \setminus \partial M^m) \setminus D$ can be pushed to infinity in $(T \setminus \partial M^m) \setminus D'$. (This is possible since there are only finitely such T .)

iii') if $x = b(y, t_0) \in B \setminus D$, then $b(y \times [0, t_0]) \cap D' = \emptyset$.

CLAIM 2. D is a π_1 -core for $Q \setminus \partial M^m$.

Toward that end, let F be a compact subset of $Q \setminus \partial M^m$ containing D , then choose $G \subseteq Q \setminus \partial M^m$ to be an even larger compact set with the following property:

(†) for each $i \in \{1, \dots, k\}$, loops in $P_{\varepsilon_i} \setminus \partial M^m$ lying outside G which contract in $(P_{\varepsilon_i} \setminus \partial M^m) \setminus C$, also contract in $(P_{\varepsilon_i} \setminus \partial M^m) \setminus F$.

Let $\alpha : [0, 1] \times [0, 1] \rightarrow (Q \setminus \partial M^m) \setminus D$. The interiors of sets $\{B_{\partial M^m}^{[0,t]}, P_{\varepsilon_1}, \dots, P_{\varepsilon_k}\}$ cover $(Q \setminus \partial M^m) \setminus D$, so we can subdivide $[0, 1]^2$ into subsquares $\{R_t\}$ so small that the image of each R_t lies in $B^{(0,t)}$ or one of the $P_{\varepsilon_i} \setminus \partial M^m$ and hence, in $B^{(0,t)} \setminus D$ or one of the $(P_{\varepsilon_i} \setminus \partial M^m) \setminus D$. Since each vertex of this subdivision is sent to a point x in $B^{(0,t)} \setminus D$ and/or $T \setminus D$, where T is an unbounded component of the intersection of the P_{ε_i} which contain the images of the subsquares containing that vertex, then by the choice of D we can push x into $(Q \setminus \partial M^m) \setminus G$ along a path that does not leave T and does not intersect D' . In those cases where $x = b(y, t_0) \in B^{(0,t)} \setminus D$, push x out of G along $b(y \times (0, 1))$, so that the track also stays in $B^{(0,t)} \setminus D'$, by property (iii').

Doing the above for each vertex adjusts α up to homotopy in $(Q \setminus \partial M^m) \setminus D'$ so that each vertex of the subdivision is taken into $(Q \setminus \partial M^m) \setminus G$ and each R_t is still taken into the same P_{ε_i} (or $B^{(0,t)}$) as before.

Next we move to the 1-skeleton of our subdivision of $[0, 1]^2$. If an edge e is the intersection $R_t \cap R_{t'}$ of two squares, i.e., e is not in $\partial([0, 1]^2)$, we use property (iii) to adjust α up to homotopy so e is mapped into $(Q \setminus \partial M^m) \setminus G$, noting that this homotopy may cause the “new” α to drift into $(Q \setminus \partial M^m) \setminus C$. (If e is sent into $B^{(0,t)}$, we can use (iii') to ensure that the push stays in $B^{(0,t)} \setminus D'$ as well.)

Do the above for each edge until the entire 1-skeleton of the subdivision of $[0, 1]^2$ is mapped into $(Q \setminus \partial M^m) \setminus G$. The image of α now lies in $(Q \setminus \partial M^m) \setminus C$. Notice that

the restriction of α to each R_t is a map of a disk into a single P_{ε_i} (or $B^{(0,t)}$) missing C_i with boundary being mapped into $P_{\varepsilon_i} \setminus G$. So by the choice of G , we may redefine α on R_t to be the same on its boundary, but to take R_t into $P_{\varepsilon_i} \setminus F$ or $B^{(0,t)} \setminus F$. Assembling the $\alpha|_{R_t}$ we get a map $\alpha' : [0, 1] \times [0, 1] \rightarrow (Q \setminus \partial M^m) \setminus F$ that agrees with α on $\partial([0, 1]^2)$. \square

Chapter 2

Characterization of pseudo-collarable manifolds with boundary

Although, in previous chapter, peripheral π_1 -stability at infinity (Condition (a) of Manifold Completion Theorem) is necessary in order for manifold completion to exist, such condition is too rigid to characterize many exotic examples related to current research trends in topology and geometric group theory. For instance, the exotic universal covering spaces produced by Mike Davis in [Dav83] are not collarable (because Condition (a) fails) yet their ends exhibit some nice geometric structure. Other examples such as (open) manifolds that satisfy Conditions (b), (c) and (d) but Condition (a) can be found in [GT03, Thm.1.3]. Define a manifold neighborhood of infinity N in a manifold M^m to be a *homotopy collar* provided $\text{Fr } N \hookrightarrow N$ is a homotopy equivalence. A *pseudo-collar* is a homotopy collar which contains arbitrarily small homotopy collar neighborhoods of infinity. A manifold is *pseudo-collarable* if it contains a pseudo-collar neighborhood of infinity. When M^m is an open manifold (or more generally, a manifold with compact boundary), Guilbault [Gui00] initiated a program to produce a generalization of Siebenmann's collaring theorem. The idea of pseudo-collars and a detailed motivation for the definition are nicely exposted in [Gui00]. Through a series of papers [Gui00, GT03, GT06], a complete characterization for pseudo-collarable manifolds with compact boundary

was provided.

Theorem 2.0.4. [GT06] *An m -manifold M^m ($m \geq 6$) with compact boundary is pseudo-collarable iff each of the following conditions holds:*

- (i) M^m is inward tame
- (ii) M^m is perfectly π_1 -semistable at infinity,
- (iii) $\sigma_\infty(M^m) \in \varprojlim \left\{ \tilde{K}_0(\pi_1(N)) \mid N \text{ a clean neighborhood of infinity} \right\}$ is zero.

Just as Theorem 1.0.1 is a natural generalization of Siebenmann's dissertation to manifolds with noncompact boundaries, it is natural to extend the study of pseudo-collarability to manifolds with noncompact boundaries. Moreover, since all completable manifolds are pseudo-collarable (a key step in the proof of Theorem 1.0.1), a more general study of pseudo-collarability also generalizes Theorem 1.0.1 in the same way that Theorem 2.0.4 generalized [Sie65]. In this chapter, our main result is the following characterization theorem.

Theorem 2.0.5 (Pseudo-collarability characterization theorem). *An m -manifold M^m ($m \geq 6$) is pseudo-collarable iff each of the following conditions holds:*

- (a) M^m is inward tame
- (b) M^m is peripherally perfectly π_1 -semistable at infinity,
- (c) $\sigma_\infty(M^m) \in \varprojlim \left\{ \tilde{K}_0(\pi_1(N)) \mid N \text{ a clean neighborhood of infinity} \right\}$ is zero.

Remark 8. It is worth noting that Condition (b) of Theorem 2.0.5 is strictly weaker than Condition (a) of Theorem 1.0.1. Furthermore, it reduces to Condition (ii) of Theorem 2.0.4 when boundary ∂M^m is compact.

The strategy of our proof is heavily relying on techniques and results developed by several substantial and technical papers [Sie65], [Gui00, GT03, GT06]. For a full understanding, the readers should be familiar with the Pseudo-collarability Characterization Theorem in [GT06] and the Manifold Completion Theorem. We will not reprove all these results, but our goal is to take shortcuts afforded by both papers, hence, provide a proof of Theorem 2.0.5 efficiently.

About the organization of this chapter: §2.1 sets forth some crucial lemmas. In §2.2 and §2.3, we prove Theorem 2.0.5. In the final section of this chapter, we discuss some related open questions.

2.1 Concatenation of one-sided h -precobordisms

The role played by one-sided h -precobordisms in the study of pseudo-collars is illustrated by the following easy proposition.

Proposition 2.1.1. *Let W_i be a disjoint union of finitely many relative one-sided h -cobordisms $\bigsqcup_j (W_i^j, A_i^j, B_i^j)$ with $A_i^j \hookrightarrow W_i^j$ a homotopy equivalence. Let $\bigsqcup_j A_i^j$ and $\bigsqcup_j B_i^j$ be A_i and B_i respectively. Suppose for each $i \geq 1$, there is a homeomorphism $h_i : B_i \rightarrow A_{i+1}$ identifying a clean codimension 0 submanifold $B_i^j \subset B_i$ with a clean codimension 0 submanifold $A_{i+1}^j \subset A_{i+1}$. Then the adjunction space*

$$N = W_1 \cup_{h_1} W_2 \cup_{h_2} W_3 \cup_{h_3} \cdots$$

is a pseudo-collar. Conversely, every pseudo-collar may be expressed as a countable union of relative one-sided h -cobordisms in this manner.

Proof. For the forward implication, the definition of relative one-sided h -cobordism implies that $\text{Fr } N = A_1 \hookrightarrow W_1 \cup_{h_1} \cdots \cup_{h_{k-1}} W_k$ is a homotopy equivalence for any finite k . Then a direct limit argument shows that $\text{Fr } N \hookrightarrow N$ is a homotopy equivalence. Hence, N is a homotopy collar. To see that N_i is a pseudo-collar, we apply the same argument to the subset $N_i = W_{i+1} \cup_{h_{i+1}} W_{i+2} \cup_{h_{i+2}} W_{i+3} \cup_{h_{i+3}} \cdots$.

For the converse, assume N is a pseudo-collar. Choose a homotopy collar $N_1 \subset \text{Int } N$ and let $W_1 = N \setminus \text{Int } N_1$. Then $\text{Fr } N \hookrightarrow W_1$ is a homotopy equivalence.

So, $(W_1, \text{Fr } N, \text{Fr } N_1)$ is a relative one-sided h -cobordism. Denote a component of N_1 by N_1^j . Let N_2' be the disjoint union of homotopy collars in N_1^j and $W_2^j = N_1^j \setminus \text{Int } N_2'$. Since $\text{Fr } N_1^j \hookrightarrow W_2^j$ is a homotopy equivalence, each $(W_2^j, \text{Fr } N_1^j, \text{Fr } N_2')$ is a relative one-sided h -cobordism. Repeating the procedure concludes the argument. See Figure 2.1.

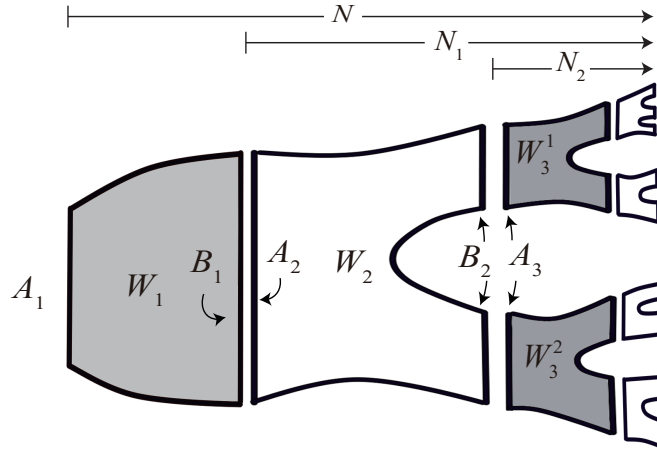

Figure 2.1: A concatenation of relative one-sided h -cobordisms.

By the cleanliness of $\text{Fr } N$ and $\text{Fr } N_i$'s, one can re-define relative one-sided h -cobordisms

$$(W_1, \text{Fr } N, \text{Fr } N_1), (W_2^j, \text{Fr } N_1^j, \text{Fr } N_2'), \dots$$

as precobordisms

$$(W_1, \text{Fr } N, \text{Fr } N_1 \cup \partial_N W_1), (W_2^j, \text{Fr } N_1^j, \text{Fr } N_2' \cup \partial_{N_1^j} W_2^j), \dots$$

Then it's easy to see that those precobordisms are one-sided h -precobordisms. \square

The following lemma proved by duality and standard covering space theory is crucial in this paper.

Lemma 2.1.2. *Let (W, A, B') be a one-sided h -precobordism with $A \hookrightarrow W$ a homotopy equivalence. Then the inclusion induced map*

$$i_{\#} : \pi_1(B') \rightarrow \pi_1(W)$$

is surjective and has perfect kernel.

Proof. The proof is similar to the argument of Theorem 2.5 in [GT03]. Let $p : \tilde{W} \rightarrow W$ be the universal covering projection, $\tilde{A} = p^{-1}(A)$ and $\hat{B}' = p^{-1}(B')$. By generalized Poincaré duality for non-compact manifolds [Hat02, Thm.3.35, P. 245],

$$H_k(\tilde{W}, \hat{B}'; \mathbb{Z}) \cong H_c^{n-k}(\tilde{W}, \tilde{A}; \mathbb{Z}),$$

where cohomology is with compact supports. Since $\tilde{A} \hookrightarrow \tilde{W}$ is a proper homotopy equivalence, all of these relative cohomology groups vanish, so $H_k(\tilde{W}, \hat{B}'; \mathbb{Z}) = 0$ for all k . It follows that $H_1(\tilde{W}, \hat{B}'; \mathbb{Z})$ vanishes. Then by considering the long exact sequence for (\tilde{W}, \hat{B}') , we have $H_0(\hat{B}'; \mathbb{Z}) = \mathbb{Z}$. Thus, \hat{B}' is connected. By covering space theory, the components of \hat{B}' are 1-1 corresponding to the cosets of $i_{\#}(\pi_1(\hat{B}'))$ in $\pi_1(W)$. So, $i_{\#}$ is surjective. To see the kernel of $i_{\#}$ is perfect, we consider the long exact sequence for (\tilde{W}, \hat{B}') again. Using $H_2(\tilde{W}, \hat{B}'; \mathbb{Z}) = 0$ together with the simple connectivity of \tilde{W} , $H_1(\hat{B}'; \mathbb{Z})$ vanishes. Hence, $\pi_1(\hat{B}')$ is perfect. By covering space theory, $\pi_1(\hat{B}') \cong \ker i_{\#}$ is perfect. \square

The following lemma plays an important role in the proof of Theorem 2.0.5. The proof follows easily from the Seifert-van Kampen Theorem.

Lemma 2.1.3. *Let X be a connected CW complex and $Y \subset X$ a connected sub-complex. Let Y' be the resulting space obtained by attaching 2-cells to Y along loops $\{l_i\}$ in Y . Then $\pi_1(Y') \cong \pi_1(Y)/N$, where N is the normal closure in $\pi_1(Y)$ of $\{l_i\}$. Let $X' = X \cup Y'$. Suppose $i_{\#} : \pi_1(Y) \rightarrow \pi_1(X)$ is the inclusion induced map. Then $\pi_1(X') \cong \pi_1(X)/N'$, where N' is the normal closure in $\pi_1(X)$ of $i_{\#}(N)$. Thus, if N is perfect, so is N' (since the image of a perfect group is perfect and the normal closure of a perfect group is perfect.)*

Lemma 2.1.4. *Let P be a compact $(n - 1)$ -manifold with boundary and $\{A_i\}$ a finite collection of pairwise disjoint compact codimension 0 clean (and connected) submanifolds of P . Let $\{(W_i, A_i, B'_i)\}$ be a collection of one-sided h -precobordisms with $A_i \hookrightarrow W_i$ a homotopy equivalence. Assume each W_i intersects P along A_i . Let $R = P \cup (\cup_i W_i)$ and $Q = (P \setminus (\cup_i A_i)) \cup (\cup_i B'_i)$. Then $\pi_1(Q) \rightarrow \pi_1(R) \cong \pi_1(P)$ is surjective and has perfect kernel.*

Proof. We begin with $Q = (P \setminus (\cup_i A_i)) \cup (\cup_i B'_i)$. Choose a finite collection of arcs in P that connect up the A_i . By adding tubular neighborhoods of these arcs, we get a clean connected codimension 0 submanifold A of P . Attaching W_1 along B'_1 . See Figure 2.2.

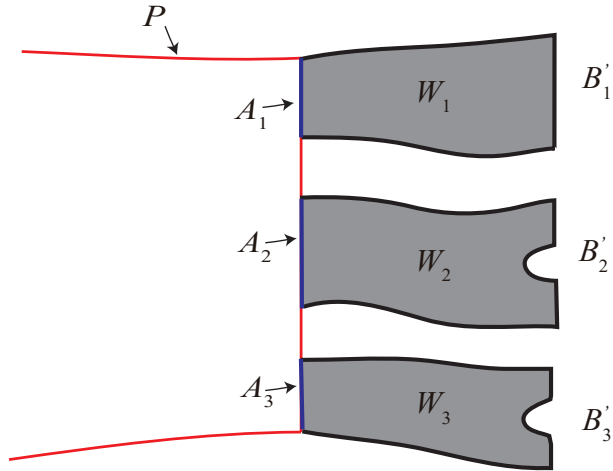

Figure 2.2: A_i is in blue and B'_i is in black. The union of red and blue arcs is P .

By Lemma 2.1.2, the inclusion induced map $\lambda_1 : \pi_1(B'_1) \rightarrow \pi_1(W_1)$ is surjective and $\ker \lambda_1$ is perfect. Let L be a wedge of loops in B'_1 which together generate $\ker \lambda_1$ and Y'_1 be the space obtained by attaching 2-cells to the interior B'_1 along these loops. Since $A_1 \hookrightarrow W_1$ is a homotopy equivalence, by Lemma 2.1.3,

$$\pi_1(W_1) \cong \pi_1(A_1) \cong \pi_1(Y'_1) \cong \pi_1(B'_1)/N_1,$$

where $N_1 = \ker \lambda_1$ is the normal closure in $\pi_1(B'_1)$ of L . Note that $A_1 \cap B'_1 = \partial A_1 = \partial B'_1$. By Seifert-van Kampen,

$$\pi_1((Q \setminus B'_1) \cup A_1) \cong \pi_1(Q \cup W_1) \cong \pi_1(Q \cup Y'_1).$$

Let $\iota_1^* : \pi_1(B'_1) \rightarrow \pi_1(Q)$ be the inclusion induced map. Then Lemma 2.1.3 implies $\pi_1(Q \cup Y'_1) \cong \pi_1(Q)/N'_1$, where N'_1 is the normal closure in $\pi_1(Q)$ of $\iota_1^*(N_1)$. Hence, $\phi_1 : \pi_1(Q) \rightarrow \pi_1(Q \cup W_1)$ is surjective and has perfect kernel.

Attaching W_2 along B'_2 in $Q \cup W_1$. Repeat the above argument, one can show that $\phi_2 : \pi_1(Q \cup W_1) \rightarrow \pi_1(Q \cup W_1 \cup W_2)$ is surjective and has perfect kernel. Assume there are k A_i 's. By induction, we have the following sequence

$$\pi_1(Q) \xrightarrow{\phi_1} \pi_1(Q \cup W_1) \xrightarrow{\phi_2} \cdots \xrightarrow{\phi_k} \pi_1(Q \cup (\cup_{i=1}^k W_i)) \quad (2.1.1)$$

Since each $\ker \phi_i$ is perfect, by Lemma 2.1.2, the composition $\Phi = \phi_k \circ \cdots \circ \phi_2 \circ \phi_1$ yields a desired surjection $\pi_1(Q) \rightarrow \pi_1(R) \cong \pi_1(P)$ and $\ker \Phi$ is perfect. \square

2.2 Proof of Theorem 2.0.5: necessity

The proof of the necessity of Conditions (a) and (c) of Theorem 2.0.5 follow readily by definition of pseudo-collar. Thus, it suffices to show that pseudo-collarability implies Condition (b).

Proof of Theorem 2.0.5 (necessity). Suppose M^m is pseudo-collarable and N is a homotopy collar. Then it's easy to see that each component N^j of N is a homotopy collar. By the definition of pseudo-collarability, we choose a desired cofinal sequence of clean neighborhoods of infinity $\{N_i^l\}_{l=1}^{k_i}$ such that each N_i^l is a homotopy collar contained in N^j . Proposition 1.4.4 guarantees that each $N_i^l \setminus \partial M^m$ is 1-ended — thus, each N_i^l is $\partial_M N_i^l$ -connected at infinity. Let $N_{i,i+s}^l = N_i^l \cap (\bigsqcup_t^{k_{i+s}} N_{i+s}^t)$ ($s = 1, 2, \dots$) is the disjoint union of finitely many components N_{i+s}^t contained in N_i^l . By Proposition 2.1.1, N^j ($= N_1^1$) can be subdivided into relative one-sided h -cobordisms. That is, each $W_i^l = \overline{N_i^l \setminus N_{i,i+1}^l}$. By definition, we may consider the sequence

$$\pi_1(\partial_M N_1^1 \cup N_{1,2}^1) \leftarrow \pi_1(\partial_M N_1^1 \cup N_{1,3}^1) \leftarrow \pi_1(\partial_M N_1^1 \cup N_{1,4}^1) \leftarrow \cdots \quad (2.2.1)$$

where base rays are suppressed and bonding homomorphisms are compositions of maps induced by inclusions and change-of-basepoint isomorphisms. Let $\overline{\partial_M N_i^l \setminus \partial_M N_{i,i+1}^l}$ be $D_{i,i+1}^l$ ($i = 1, 2, 3, \dots$) and $D_{i,i+2}^l = D_{i,i+1}^l \cup D_{i+1,i+2}^l$. Consider the following diagram. Each bonding map in the top row is an inclusion.

$$\begin{array}{ccccccc}
\partial_M N_1^1 \cup N_{1,2}^1 & \hookleftarrow & \partial_M N_1^1 \cup N_{1,3}^1 & \hookleftarrow & \partial_M N_1^1 \cup N_{1,4}^1 & \hookleftarrow & \dots \\
\uparrow \text{incl.} & & \uparrow \text{incl.} & & \uparrow \text{incl.} & & \\
D_{1,2}^1 \cup \text{Fr } N_{1,2}^1 & & D_{1,3}^1 \cup \text{Fr } N_{1,3}^1 & & D_{1,4}^1 \cup \text{Fr } N_{1,4}^1 & & \dots
\end{array}$$

Since each $\text{Fr } N_i^l \hookrightarrow N_i^l$ is a homotopy equivalence, all the vertical maps are homotopy equivalence. By ¶3 in the proof of Proposition 2.1.1, $(W_i^l, \text{Fr } N_i^l, \text{Fr } N_{i,i+1}^l \cup \partial_M W_i^l)$ is a one-sided h -precobordism. Apply Lemma 2.1.4,

$$\pi_1(D_{1,i+2}^1 \cup \text{Fr } N_{1,i+2}^1) \twoheadrightarrow \pi_1(D_{1,i+1}^1 \cup \text{Fr } N_{1,i+1}^1)$$

is surjective and has perfect kernel. □

2.3 Proof of Theorem 2.0.5: sufficiency

We begin the proof of the “sufficiency argument” with three theorems that will be key ingredients in the proof. Each is a straightforward extension of an established result from the literature.

The following theorem is a modest generalization of the Pseudo-collarability Characterization Theorem in [GT06] to some manifolds with noncompact boundary in the same way the Siebenmann’s “Relativized Main Theorem 10.1” provided a mild extension of the Main Theorem of [Sie65] to some manifolds with noncompact boundary.

Theorem 2.3.1 (Relativized Pseudo-collarability Characterization Theorem). *Suppose M^m ($m \geq 6$) is one-ended and ∂M^m is homeomorphic to the interior of a compact manifold. Then M^m is pseudo-collarable iff M^m is*

1. inward tame,
2. $\pi_1(\varepsilon(M^m))$ is perfectly semistable,

3. $\sigma_\infty(M^m) = 0$.

Quillen’s famous “plus construction” [Qui71] or [FQ90, Section 11.1] provides a partial converse to Lemma 2.1.2.

Theorem 2.3.2 (The Relativized Plus Construction). *Let B be a compact $(n - 1)$ -manifold ($n \geq 6$) and $h : \pi_1(B) \rightarrow H$ a surjective homomorphism onto a finitely presented group such that $\ker(h)$ is perfect. There exists a compact n -dimensional nice relative cobordism (W, A, B) such that $\ker(\pi_1(B) \rightarrow \pi_1(W)) = \ker h$, and $A \hookrightarrow W$ is a simple homotopy equivalence. These properties determine W uniquely up to homeomorphism rel B .*

Remark 9. For $n = 5$, the above theorem still holds as long as H is restricted to be “good” (see [FQ90, Th. 11.1A, P.195]). For $n \geq 6$, the proof is the same as the proof of Th. 11.1A in [FQ90, P.195] except that 2-spheres on which the 3-handles are attached embedded simply by general position. When $n = 4$, the theorem is false.

When a nice rel one-sided h -cobordism has trivial Whitehead torsion, ie, when the corresponding homotopy equivalence is simple, we refer to it as a *nice rel plus cobordism*.

Theorem 2.3.3 (Relativized Embedded Plus Construction). *Let R be a connected manifold of dimension at least 6; B a compact codimension 0 submanifold of ∂R ; and*

$$G \subseteq \ker(\pi_1(B) \rightarrow \pi_1(R))$$

a perfect group which is the normal closure in $\pi_1(B)$ of a finite set of elements. Then there exists a nice rel plus cobordism (W, A, B) embedded in R which is the identity on B for which $\ker(\pi_1(B) \rightarrow \pi_1(W)) = G$.

Proof. The proof of Theorem 3.2 in [GT06] will work for our situation with simple replacement of plus construction by the relativized plus construction and duality by generalized Poincaré duality [Hat02, Thm.3.35, P. 245] for noncompact manifolds.

□

Proof of Theorem 2.3.1. For a full understanding, the reader should be familiar with the proof of the Main Existence Theorem [Gui00]. To generalize all the arguments made in [Gui00], especially Theorem 5, Lemmas 13-15, one need use frontiers Fr of generalized k -neighborhoods to replace boundaries ∂ . All handle operations should be performed away from ∂M^m . This is doable for nearly the same reasons given by Siebenmann for [Sie65, Th.10.1]; in particular, all handle moves in the proof [GT06, Th. 1.1] can be performed away from ∂M^m . More specifically, the above procedure will assure the end has generalized $(n - 3)$ -neighborhoods $\{U_i\}$. To modify $\{U_i\}$ to generalized $(n - 2)$ -neighborhoods, one has to replace Theorem 3.2 in [GT06, P.554] by Theorem 2.3.3. Then imitate the argument in [GT06, P.554-555] via replacing ∂ by Fr and keeping the handle decompositions away from ∂M^m . □

The proof of the sufficiency of Theorem 2.0.5 follows readily from the following result.

Proposition 2.3.4. *If M^m satisfies Conditions (a) - (c) of Theorem 2.0.5 then there exists a clean compact exhaustion $\{C_i\}$ so that, for the corresponding neighborhoods of infinity $\{N_i\}$, $\text{Fr } N_i \hookrightarrow N_i$ is a homotopy equivalence.*

Proof. The proof is a variation on the argument of Proposition 1.9.2. By Lemma 1.5.1 and the definition of peripheral perfect semistability at infinity, we can begin with a clean compact exhaustion $\{C_i\}_i^\infty$ of M^m and a corresponding sequence of neighborhoods of infinity $\{N_i\}_{i=1}^\infty$, each with a finite set of connected components $\{N_i^j\}_{j=1}^{k_i}$, so that for all $i \geq 1$ and $1 \leq j \leq k_i$,

- i) N_i^j is inward tame,
- ii) N_i^j is $(\partial_M N_i^j)$ -connected and $(\partial_M N_i^j)$ -perfectly-semistable at infinity, and
- iii) $\sigma_\infty(N_i^j) = 0$.

By Lemmas 1.5.1 and 1.3.3, we have

- i') $N_i^j \setminus \partial M^m$ is inward tame,

ii') $N_i^j \setminus \partial M^m$ is 1-ended and has perfectly semistable fundamental group at infinity,
and

iii') $\sigma_\infty(N_i^j \setminus \partial M^m) = 0$.

These are precisely the hypotheses of Theorem 2.3.1. That means $N_i^j \setminus \partial M^m$ contains a homotopy collar neighborhood of infinity V_i^j , i.e., $\partial V_i^j \hookrightarrow V_i^j$ is a homotopy equivalence. Following the proof of Theorem 2.3.1, one can further arrange $\partial N_i^j \setminus \partial M^m$ ($= \text{int}(\text{Fr } N_i^j)$) and ∂V_i^j contain clean compact codimension 0 submanifolds A_i^j and B_i^j , respectively, so that $\text{int}(\text{Fr } N_i^j) \setminus \text{int } A_i^j = \partial V_i^j \setminus \text{int } B_i^j \approx \partial A_i^j \times [0, 1)$. See Figure 2.3.

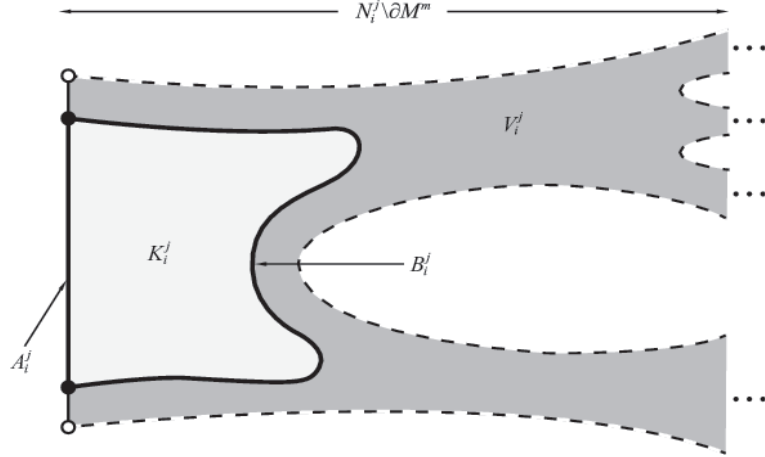

Figure 2.3: V_i^j is a homotopy collar.

Note that $K_i^j = \overline{N_i^j \setminus V_i^j}$ is a clean codimension 0 submanifold of M^m intersecting C_i in A_i^j . To save on notation, we replace C_i with $C_i \cup (\cup K_i^j)$, which is still a clean compact codimension 0 submanifold of M^m , but with the additional property that

$$\text{int}(\text{Fr } N_i) \hookrightarrow N_i \setminus \partial M^m \text{ is a homotopy equivalence.} \quad (2.3.1)$$

Since adding $\partial_M N_i$ back in does not affect homotopy types, we have

$$\text{Fr } N_i \hookrightarrow N_i \text{ is a homotopy equivalence.} \quad (2.3.2)$$

Having enlarged the C_i , if necessary, one can easily retain the property that $C_i \subseteq \text{Int } C_{i+1}$ for all i by passing to a subsequence. Then $N_i = \overline{M^m \setminus C_i}$ gives a desired nested cofinal sequence of clean neighborhoods of infinity $\{N_i\}$ with the property that each inclusion $\text{Fr } N_i \hookrightarrow N_i$ is a homotopy equivalence, i.e., M^m is pseudo-collarable. \square

2.4 Questions

The idea of pseudo-collarability is related to a \mathcal{Z} -compactification. Obviously, completable manifolds are both pseudo-collarable and \mathcal{Z} -compactifiable. Despite the fact that many manifolds such as Davis' manifolds are both pseudo-collarable and \mathcal{Z} -compactifiable but not completable, the relationship between pseudo-collarable manifolds and \mathcal{Z} -compactifiable manifolds are not well-understood. There are several interesting questions around such topic.

Question 1. *Are pseudo-collarability and Condition (d) of Theorem 1.0.1 sufficient for manifolds to be \mathcal{Z} -compactifiable?*

Question 2. *Are \mathcal{Z} -compactifiable manifolds pseudo-collarable?*

We suspect the answer to Question 2 is negative. Crossing manifolds constructed in [KM62], [Ste77] and [Gu18] with half-open interval $[0, 1)$ might be potential counterexamples. However, the biggest obstacle is closely related to the following question in knot theory.

Question 3. *Let K be a trefoil knot and $\text{WD}(K)$ be a twisted Whitehead double of K . Is the knot group of $\text{WD}(K)$ hypoabelian?*

Definition 2.4.1. A group G is said to *hypoabelian* if the following equivalent conditions are satisfied:

1. G contains no nontrivial perfect subgroup
2. the transfinite derived series terminates at the identity. (Note that this is the transfinite derived series, where the successor of a given subgroup is its

commutator subgroup and subgroups at limit ordinals are given by intersecting all previous subgroups.)

Question 2 is related to the following open question posed in [GT03]

Question 4. *Can a \mathcal{Z} -compactifiable open n -manifold fail to be pseudo-collarable?*

BIBLIOGRAPHY

- [ADG97] F. D. Ancel, M. W. Davis, and C. R. Guilbault, *CAT(0) reflection manifolds*, Geometric topology (Athens, GA, 1993), AMS/IP Stud. Adv. Math., vol. 2, Amer. Math. Soc., Providence, RI, 1997, pp. 441–445. MR 1470741
- [AG99] Fredric D. Ancel and Craig R. Guilbault, *\mathcal{Z} -compactifications of open manifolds*, Topology **38** (1999), no. 6, 1265–1280. MR 1690157
- [BM91] Mladen Bestvina and Geoffrey Mess, *The boundary of negatively curved groups*, J. Amer. Math. Soc. **4** (1991), no. 3, 469–481. MR 1096169
- [Coh73] Marshall M. Cohen, *A course in simple-homotopy theory*, Springer-Verlag, New York- Berlin, 1973, Graduate Texts in Mathematics, Vol. 10. MR 0362320
- [CP95] Gunnar Carlsson and Erik Kjr Pedersen, *Controlled algebra and the Novikov conjectures for K- and L-theory*, Topology **34** (1995), no. 3, 731–758. MR 1341817
- [CS76] T. A. Chapman and L. C. Siebenmann, *Finding a boundary for a Hilbert cube manifold*, Acta Math. **137** (1976), no. 3–4, 171–208. MR 0425973
- [Dav83] M. W. Davis, *Groups generated by reflections and aspherical manifolds not covered by Euclidean space*, Ann. Math. **117** (1983) 293–325.
- [Eps66] D. B. A. Epstein, *The degree of a map*, Proc. London Math. Soc. (3) **16** (1966), 369–383. MR 0192475

- [Fer00] Steven C. Ferry, *Stable compactifications of polyhedra*, Michigan Math. J. **47** (2000), no. 2, 287–294. MR 1793625
- [FL05] F. T. Farrell and J.-F. Lafont, *EZ-structures and topological applications*, Comment. Math. Helv. **80** (2005), no. 1, 103–121. MR 2130569
- [FQ90] Michael H. Freedman and Frank Quinn, *Topology of 4-manifolds*, Princeton Mathematical Series, vol. 39, Princeton University Press, Princeton, NJ, 1990. MR 1201584
- [Fre82] Michael Hartley Freedman, *The topology of four-dimensional manifolds*, J. Differential Geom. **17** (1982), no. 3, 357–453. MR 679066
- [FW95] Steven C. Ferry and Shmuel Weinberger, *A coarse approach to the Novikov conjecture, Novikov conjectures, index theorems and rigidity*, Vol. 1 (Oberwolfach, 1993), London Math. Soc. Lecture Note Ser., vol. 226, Cambridge Univ. Press, Cambridge, 1995, pp. 147–163. MR 1388300
- [Geo08] R. Geoghegan, *Topological methods in group theory*, Graduate Texts in Mathematics, vol. 243, Springer, New York, 2008. MR 2365352
- [GG17] Shijie Gu and Craig R. Guilbault, *Compactifications of manifolds with boundary*, preprint. arXiv: 1712.05995
- [GM17] Craig R. Guilbault and Molly A. Moran, *Proper homotopy types and Z -boundaries of spaces admitting geometric group actions*, arXiv:1707.07760 [math.GT].
- [GT03] C. R. Guilbault and F. C. Tinsley, *Manifolds with non-stable fundamental groups at infinity. II*, Geom. Topol. **7** (2003), 255–286. MR 1988286
- [GT06] C. R. Guilbault and F. C. Tinsley, *Manifolds with non-stable fundamental groups at infinity. III*, Geom. Topol. **10** (2006), 541–556. MR 2224464
- [Gu18] Shijie Gu, *Contractible open manifolds which embed in no compact, locally connected and locally 1-connected metric space*, in progress.

- [Gui00] Craig R. Guilbault, *Manifolds with non-stable fundamental groups at infinity*, *Geom. Topol.* **4** (2000), 537–579. MR 1800296
- [Gui01] Craig R. Guilbault, *A non- Z -compactifiable polyhedron whose product with the Hilbert cube is Z -compactifiable*, *Fund. Math.* **168** (2001), no. 2, 165–197. MR 1852740
- [Gui07] Craig R. Guilbault, *Products of open manifolds with \mathbb{R}* , *Fund. Math.* **197** (2007), 197–214. MR 2365887
- [Gui16] Craig R. Guilbault, *Ends, shapes, and boundaries in manifold topology and geometric group theory*, *Topology and geometric group theory*, Springer Proc. Math. Stat., vol. 184, Springer, [Cham], 2016, pp. 45–125. MR 3598162
- [Hat02] Allen Hatcher, *Algebraic topology*, Cambridge University Press, Cambridge, 2002. MR 1867354
- [KM62] J. M. Kister and D. R. McMillan, Jr., *Locally Euclidean factors of \mathbb{E}^4 which cannot be embedded in \mathbb{E}^3* , *Ann. of Math.* **76** (1962), 541–546.
- [KS88] Sławomir Kwasik and Reinhard Schultz, *Desuspension of group actions and the ribbon theorem*, *Topology* **27** (1988), no. 4, 443–457. MR 976586
- [O’B83] Gary O’Brien, *The missing boundary problem for smooth manifolds of dimension greater than or equal to six*, *Topology Appl.* **16** (1983), no. 3, 303–324. MR 722123
- [Qui71] D. Quillen, *Cohomology of groups*, from: “Actes du Congrès International des Mathématiciens (Nice, 1970), Tome 2”, Gauthier-Villars, Paris (1971) 47–51. MR 0488054
- [Qui82] Frank Quinn, *Ends of maps. III. Dimensions 4 and 5*, *J. Differential Geom.* **17** (1982), no. 3, 503–521. MR 679069

- [RS82] Colin Patrick Rourke and Brian Joseph Sanderson, *Introduction to piecewise-linear topology*, Springer Study Edition, Springer-Verlag, Berlin-New York, 1982, Reprint. MR 665919
- [Sie65] Laurence Carl Siebenmann, *The obstruction to finding a boundary for an open manifold of dimension greater than five*, ProQuest LLC, Ann Arbor, MI, 1965, Thesis (Ph.D.)Princeton University. MR 2615648
- [Ste77] Robert William Sternfeld, *A contractible open n -manifold that embeds in no compact n - manifold*, ProQuest LLC, Ann Arbor, MI, 1977, Thesis (Ph.D.)-The University of Wisconsin - Madison. MR 2627427
- [Tuc74] Thomas W. Tucker, *Non-compact 3-manifolds and the missing-boundary problem*, *Topology* **13** (1974), 267–273. MR 0353317
- [Wal65] C. T. C. Wall, *Finiteness conditions for CW-complexes*, *Ann. of Math. (2)* **81** (1965), 56–69. MR 0171284
- [Wei87] Shmuel Weinberger, *On fibering four- and five-manifolds*, *Israel J. Math.* **59** (1987), no. 1, 1–7. MR 923658

CURRICULUM VITAE

Shijie Gu

EDUCATION

Ph.D., Mathematics

University of Wisconsin, Milwaukee, Wisconsin

August 2018

Advisor: Dr. Craig Guilbault

Dissertation: *COMPACTIFICATIONS OF MANIFOLDS WITH BOUNDARY*

Area of Study: Geometric Topology

M.S., Mathematics

University of Nevada, Reno, NV

May 2014

B.S., Mathematics

Shanghai University, Shanghai, China

July 2011

RESEARCH AND WORK EXPERIENCE

Research Assistant

06/2016 to 06/2017

Department of Mathematical Science, University of Wisconsin, Milwaukee

- Worked with Dr. Sergey Kravtsov on a NSF fund project about building a suite of numerically efficient and extremely statistically accurate, essentially bias-free emulators of non-stationary atmospheric fields.
- Invented a new objective filtering and signal processing method to show the difference between the observed and simulated climate variability is dominated by a multidecadal signal propagating across the globe.
- Used Matlab in pre-processing and compressing monthly historical surface atmospheric temperature (SAT) data sets based on the standard Empirical Orthogonal Function analysis.
- Established linear inverse models to mimic stationary internal climate variability in the observed and simulated SAT time series

Research Assistant

09/2012 to 05/2014

Department of Mathematics & Statistics, University of Nevada, Reno

- Collaborated with Dr. Mark Pinsky to apply dynamics theory and observer theory to design observers to approximate derivatives and forecast solutions in nonlinear systems.

Risk Infrastructure Officer

07/2011 to 06/2012

HSBC Technology & Services (China) Limited, Shanghai, China

- Supported implementation of credit strategies in decision system.
- Provided support to system testing and involved in impact analysis.
- Conducted initial deviation discussion and provided results for manager decision.
- Supported User Acceptance Testing of SMg3/StrategyWare.
- Supported automation in Smg3 deployment area.

TEACHING EXPERIENCE

Instructor for Calculus and analytic geometry

01/2018 to current

University of Wisconsin, Milwaukee

- Responsible for syllabus, all lectures, homework assignments, writing tests and final grades.

Teaching Assistant

09/2017 to 12/2017

University of Wisconsin, Milwaukee

- Led discussion sessions of Survey in Calculus and analytic geometry.

Teaching Assistant

09/2014 to 05/2016

University of Wisconsin, Milwaukee

- Assisted with all instructional duties for Mathematical Literacy I & II: Answering group work questions, grading group work & homework problems and operating D2L system.

- Led discussion sessions of Survey in Calculus and analytic geometry.

Teaching Assistant and Instructor 08/2012 to 07/2014
University of Nevada, Reno

- Teaching Assistant: Led recitation sections of Precalculus and Calculus I & II during the spring and fall semesters.
- Instructor for Precalculus during the summer semesters: Responsible for syllabus, all lectures, homework assignments, writing tests and final grades.

PROFESSIONAL SERVICES

Reviewer for Mathematical Reviews 04/2018 to current

Reviewer for zbMath 06/2015 to current

Editor 06/2013 to 01/2014
American Mathematical Society Graduate Students Blog

- Edited and wrote math related articles on the AMS Grad Student Blog.

Coordinator of HTSC Task Force Team 08/2011 to 01/2012
HSBC Technology & Services (China) Limited, Shanghai, China

- Co-organised HSBC & HTSC Annual Dinner: directed music of play *More than Hero*, Ritz-Carlton Hotel, Shanghai, China.
- Co-organised HTSC Anniversary Celebration, Fairmont Hotel, Yangcheng Lake, China.

AWARDS AND FUNDS

- AMS Graduate Student Travel Grant for JMM 2018.
- Research Excellence Award, University of Wisconsin, Milwaukee, 2015 & 2017.

- Chancellor's Graduate Student Award, University of Wisconsin, Milwaukee, 2014-2016.
- International Graduate Student Award, University of Nevada, Reno, 2014.
- Third Prize in National Mathematical Contest in Modeling, China, 2010.

PRESENTATIONS AND TALKS

- *Compactifications of manifolds with boundary*, University of North Carolina Wilmington, Wilmington, NC, 03/2018.
- *Compactifications of manifolds with boundary*, Geometric Topology Session, the 52nd Annual Spring Topology and Dynamical Systems Conference, Auburn, AL, 03/2018.
- *Compactifications of manifolds with boundary*, the 34th Annual Workshop in Geometric Topology, Provo, UT, 06/2017.
- *Compactifications of manifolds with boundary*, Geometric Topology session, the 51st Annual Spring Topology and Dynamical Systems Conference, Jersey City, NJ, 03/2017.
- *A hierarchy for closed n -cell-complements*, Special Session on Geometric Topology, AMS Fall Eastern Sectional Meeting, Rutgers University, New Brunswick, NJ, 11/2015.
- *Nested defining sequences and 1 dimensionality of decomposition elements*, the 32nd Annual Workshop in Geometric Topology, Texas Christian University, TX, 06/2015.
- *On the shrinkable u.s.c. decomposition spaces of spheres*, the 31st Annual Workshop in Geometric Topology, University of Wisconsin, Milwaukee, 06/2014.

- *On the shrinkable u.s.c. decomposition spaces of spheres*, Special Session on Geometric Topology, AMS Spring Southeastern Sectional Meeting, University of Tennessee, Knoxville, TN, 03/2014.
- *Study of weakly discontinuous solutions for hyperbolic differential equations based on wavelet transform methods*, 2013 SIAM Annual Meeting, San Diego, CA, 07/2013.

PREPRINTS AND PUBLICATIONS

1. S. Gu, *Characterization of pseudo-collarable manifolds with boundary*, preprint.
2. S. Kravtsov, C. Grimm and S. Gu, *Global-Scale multidecadal variability missing in state-of-the-art*, submitted.
3. S. Gu, C. R. Guilbault, *Compactifications of manifolds with boundary*, preprint. arXiv:1712.05995
4. S. Gu, *Degree of homogeneity on suspensions of manifolds*, *Topology Appl.* **238** (2018), 20–23.
5. S. Gu, *On small metric spheres and local cone structures of Busemann G -spaces*, *Houston J. Math.*, to appear.
6. R. J. Daverman, S. Gu, *A hierarchy for closed n -cell-complements*, *Rocky Mountain J. Math.* **47** (2017), no. 7, 2133–2166.
7. S. Gu, *Approximating resolutions by cell-like maps with codimension-three point inverses*, *Topology Appl.* **232** (2017), 22–28.
8. R. J. Daverman, S. Gu, *Nested defining sequences and 1 dimensionality of decomposition elements*, *Topology Appl.* **227** (2017), 59–63.
9. S. Gu, *On the equivalence of Alexandrov curvature and Busemann curvature*, *Turk. J. Math.*, **41** (2017), 211–215.

10. S. Gu, *On the shrinkable u.s.c. decomposition spaces of spheres*, Topology Appl. **173** (2014), 83–90.
11. S. Gu, *Robust estimation of higher order derivatives of solutions to some non-linear systems under uncertainties*, M. S. Thesis, University of Nevada, Reno.
12. S. Gu, *A study of weakly discontinuous solutions for hyperbolic differential equations based on wavelet transform methods*, Int. J. Appl. Math. (1) **127** (2014), 1–12.

COMPUTER SKILLS

Matlab, Maple, C, Python, Snappy, Sage, GAP, Smg3/Strategyware, SMF, MKS, Limits & Mitigants