

May 2019

Experimental and Analytical Study of the Novel Static Flow Meters

Ehsan Sanatizadeh
University of Wisconsin-Milwaukee

Follow this and additional works at: <https://dc.uwm.edu/etd>



Part of the [Engineering Commons](#)

Recommended Citation

Sanatizadeh, Ehsan, "Experimental and Analytical Study of the Novel Static Flow Meters" (2019). *Theses and Dissertations*. 2244.

<https://dc.uwm.edu/etd/2244>

This Thesis is brought to you for free and open access by UWM Digital Commons. It has been accepted for inclusion in Theses and Dissertations by an authorized administrator of UWM Digital Commons. For more information, please contact open-access@uwm.edu.

EXPERIMENTAL AND ANALYTICAL STUDY OF THE NOVEL STATIC FLOW METERS

by

Ehsan Sanatizadeh

A Thesis Submitted in
Partial Fulfillment of the
Requirements for the Degree of

Master of Science
in Engineering

at

The University of Wisconsin-Milwaukee

May 2019

ABSTRACT

EXPERIMENTAL AND ANALYTICAL STUDY OF THE NOVEL STATIC FLOW METERS

by

Ehsan Sanatizadeh

The University of Wisconsin-Milwaukee, 2019
Under the Supervision of Professor Nathan Salowitz

Flow metering is the measurement of the volume of a substance passing through a cross sectional area per unit time. In various industries, many diverse types of flow meters are used to evaluate and control the velocity of the fluid passing through a system. In the water industry, flow meters are crucial in evaluating the performance of large scale industrial water filtration systems, and in the detection of underperforming elements. Reliable flow metering technology is essential to guarantee the production of clean safe drinking water.

An ongoing issue with existing flow metering technologies is cost effectiveness. This is a major limiting factor for widespread use. One of the focuses of this research was expense reduction of the system and the final product. The end goal was to create and validate designs for low cost static, and robust flow sensors. The objective of this project was to design a simple, easily manufactured flow meter with no moving parts. By reducing the cost, precision is sacrificed in some aspects, however, the design still proved to be a viable substitution.

Differential pressure flow metering was selected based on target and orifice plate meters to generate the main idea of the project. Simple designs were pursued utilizing strain gauges and basic data acquisition systems, and ultimately three designs were created. The general design methodology involved mounting a strain gauge on a custom designed laser cut Acrylic plate, and inserting it as a pipe cross section to target water flow. For each design equations were analytically derived and specimens were created with varying geometric parameters. A multi-level factorial analysis was performed on each design to identify which geometric properties were critical to flow sensitivity. Three variables (thickness, length, width) for each design were studied based on the derived equations.

Based on the results, thickness of the designed plate was the most effective parameter in ensuring accuracy. Lower thickness leads to a more sensitive system and better results. Width and Length of the cut area on which strain gauge was mounted were other geometric properties thoroughly

studied. Designs were developed that were found to be inert to certain potential manufacturing variation through analytical analysis with experimental validation.

Beam bending was a critical component to all the designs created. One design was created that measured flow independent of beam width, and another was created which produced results independent of beam length. Across all designs, sensitivity and flow measurement were highly sensitive to the thickness of the beam.

TABLE OF CONTENTS

Introduction.....	1
Motivation.....	1
Background.....	1
Differential Pressure Flow Meters.....	1
Velocity Flow Meters.....	5
Positive Displacement Flow Meters.....	9
Mass Flow Meters.....	10
Challenges.....	13
Objective.....	13
Approach.....	13
Major tasks.....	13
Part Selection.....	14
Strain gauge.....	14
Wheatstone bridge.....	14
Acrylic plate.....	15
Pressure sensor.....	15
Data acquisition system (Arduino uno).....	18
DAQ (Data acquisition) Device.....	18
Arduino.....	18
Assembly and Testing.....	19
How to apply strain gauge on a surface?.....	19
Fundamental equations.....	25

Designs.....	27
Classic target meter	27
Deriving the equations for Classic target meter	27
Hybrid target meter	30
Deriving the equations for Hybrid target meter	30
Hybrid cantilevered meter	32
Deriving the equation for Hybrid cantilevered meter	32
Results.....	34
Pressure drop and Strain vs. Flow rate	34
Classic target meter	34
Hybrid target meter.....	35
Hybrid cantilevered meter	37
Factorial Analysis.....	38
Classic target meter	38
Hybrid target meter.....	40
Hybrid Cantilevered meter	41
Conclusions.....	43
References.....	44
Appendices.....	47
Appendix A: Testing plan for classic target meter.....	47
Appendix B: Testing plan for Hybrid target meter	48
Appendix C: Testing plan for Hybrid cantilevered meter.....	49

LIST OF FIGURES

Figure 1- Target flow meter	6
Figure 2- Target flow meter inside look [21].....	7
Figure 3- Positive displacement.....	9
Figure 4- Schematic of a Coriolis flow sensor [34].....	12
Figure 5- Wheatstone bridge [36].....	14
Figure 6- Blue Robotics Inc. [41]	16
Figure 7- 2D drawing of the Blue Robotics pressure sensor [41].....	17
Figure 8- I2C Level Converter [42]	17
Figure 9- Arduino uno [46].....	18
Figure 10- Primary designs.....	19
Figure 11- Mounted strain gauge on the beam of the Acrylic plate	20
Figure 12- Electromagnetic flow meter	21
Figure 13- Pump	21
Figure 14- Pump's safe mode controller	22
Figure 15- Testing pipes and the joint	22
Figure 16- Testing setup	23
Figure 17- Testing plates	24
Figure 18- Bending parameters of beam [51].....	25
Figure 19- Classic target meter	27
Figure 20- Classic target meter	27
Figure 21- Hybrid target meter	30
Figure 22- Hybrid target meter	30

Figure 23- Hybrid cantilevered meter.....	32
Figure 24- Hybrid cantilevered meter.....	32
Figure 25- Pressure drop vs Flowrate for Classic target meter plate	34
Figure 26- Strain vs. flow rate for classic target meter plate	35
Figure 27- Pressure drop vs flow rate in hybrid target meter plate	36
Figure 28- Strain vs flow rate in hybrid target meter plate.....	36
Figure 29- Pressure drop vs flowrate for hybrid Cantilevered plate.....	37
Figure 30- Strain vs flow rate for hybrid Cantilevered plate	38
Figure 31- Pareto chart of the standardized effects of classic target meter design.....	39
Figure 32- Pareto chart of the effects of the classic target meter design	39
Figure 33- Pareto chart of the standardized effects of the hybrid target meter design	40
Figure 34- Pareto chart of the effects of the hybrid target meter design	41
Figure 35- Pareto chart of the standardized effects for the hybrid cantilevered design	41
Figure 36- Pareto chart of the effects for the hybrid cantilevered design.....	42

LIST OF TABLES

Table 1- Pressure sensor decision matrix [40].....	16
--	----

Introduction

Flow metering is the measurement of the mass or volume of a fluid passing through a given area per unit time [1]. Many industries are interested in flow metering for process control, including chemical suppliers, food and beverage manufacturers, and water filtration utilities. There has been significant interest in residential flow metering to measure both water usage and performance of consumer water treatment products. However, the high cost of existing flow meters is prohibitive for this application and many flow meters have limited applicability to a small range of applications. Similarly, there has been interest in mass deployment of flow meters in industrial settings to monitor the performance of individual components, which has faced the same issues and hurdles. Therefore, the objective of this research was to create simple, static, low cost, scalable designs for water flow meters.

Motivation

Water is quickly becoming one of the most critical natural resources. Currently two-thirds of the global population lives with limited access to water. According to the world health organization, globally, 2.4 billion people do not have access to adequate sanitation and 663 million people do not have access to clean water [2]. It is predicted that by 2050, global demand for water will increase by as much as 50%, mostly in developing countries in Africa and Asia. The United States has also seen challenges with its water infrastructure in recent years highlighted by water contamination in Flint Michigan and droughts in the western United States [3] [4]. A critical component of water management and treatment is metering of the water to measure distribution and to ensure proper treatment, from industrial scales to the individual end user [5].

Background

This section presents a review of different types of flow meters, their underlying operational principle, advantages and drawbacks, and common applications. The broad importance of water metering has led to the development of many different types of flow meters available in the market. Each type is different in its construction, employing differing materials, fluid dynamics principles, and sensing technologies. Many of these technologies address specific needs, often making them application specific or limiting broad usage. There are many variations to each type of flow meter presented here. Because of the wide array of existing flow meters and the goals of this project, the review is focused on flow meters with low cost and with no moving parts.

Differential Pressure Flow Meters

Differential pressure flowmeters create a pressure change in the flow that varies as the flow rate changes. Comparison of the pressure differential at two points across this pressure change provide information about the flow rate. The measurement and meter can also be characterized as measuring free stream static pressure or stagnation pressure of the flow.

As the name implies, differential pressure flow meters compare a difference in pressure at two points in a flow. It is important to differentiate between free stream static pressure, free stream dynamic pressure, and stagnation pressure in the design of such devices. Depending on the specific type of differential pressure flow meter, the governing equations will include forms of conservation of mass and energy. For the water metering herein, the flow will be assumed to be incompressible and steady.

Differential pressure flow meters themselves consist of a constriction, obstruction, or change in the flow that causes a flow rate dependent pressure variation, and pressure sensors placed at specific points in the flow to compare the change in pressure. Different techniques can be used to create the pressure change and to measure the results. The pressure variation can be created by a change in the cross-sectional area of a pipe, an obstruction across the pipe, or a change in direction of the flow, essentially anything that causes drag or change in velocity. Measurement of the pressure variation can be performed using multiple pressure sensors placed spanning the pressure change, or alternatively piping around the region can be connected to a differential pressure meter.

Because Differential pressure flow meters' measure pressure at two points in the flow they can only provide an indication of the average velocity and related volumetric or mass flow rates.

Orifice Plate

One of the most common techniques for differential pressure flow metering is to induce a pressure drop by placing an "orifice plate", a plate with holes in it, in the stream along a constant diameter pipe. The plate is designed to induce significant drag and viscous effects. Conservation of mass and incompressible assumptions with a constant diameter pipe dictate that the volume and therefore velocity of the flow must be the same upstream and downstream. Therefore, the energy dissipated by the drag and viscous effects can only come from the pressure term.

Advantages

- Small and easy to install or remove.
- Can have small pressure drop of which 60% to 65% is recovered.
- Easy to maintain.
- Wide operational range.
- Simple construction.
- Well suited for most gases and liquids.
- Inexpensive.
- Price does not increase with size [6].

Disadvantages

- Needs homogeneous fluid.
- Needs single phase liquid.

- Needs axial velocity vector flow.
- Cause a pressure drop in fluid.
- Accuracy is affected by pressure, fluid density, and viscosity.
- Fluid viscosity limits the measuring range.
- Needs straight pipe runs to make sure accuracy is maintained.
- Pipe must be full, especially for liquid flow measurement [6].

Venturi Tube

Venturi Tubes are another type of differential flow meter that depend on a constriction in the flow. Contrary to orifice plates, Venturi tubes are designed to minimize drag and viscous effects and the pressure differential is measured at points with two different cross-sectional areas. Without viscous losses, conservation of energy in the form of Bernoulli's equation can be applied in combination with conservation of mass and volume to relate the differing pressure measurements to the velocity

Bernoulli's equation (1) is a statement of conservation of energy for steady, incompressible, isentropic flow relating free stream static and free stream dynamic pressures [7] [8] [9]. If the flow is level, with no gravitational effects, Bernoulli's equation can be expressed as (1).

$$\frac{1}{2}\rho v_1^2 + P_1 = \frac{1}{2}\rho v_2^2 + P_2 \quad (1)$$

Where ρ is the fluid mass density, v is the flow velocity, and P is the free stream static pressure.

Conservation of mass combined with the incompressible assumption means that the volumetric flow rate remains constant as shown in (2), where A is the cross-sectional area of the pipe.

$$A_1 v_1 = A_2 v_2 \quad (2)$$

These equations can be combined and manipulated to create a relationship between the velocity and pressures based on the known areas as shown in (3)

$$v_1 = \sqrt{\frac{2(P_2 - P_1)}{\rho \left(1 - \frac{A_1^2}{A_2^2}\right)}} \quad (3)$$

Advantages

- Low chance of clogging with sediment.
- Co-efficient of discharge (the ratio between the actual flow and theoretical flow) is high.
- No moving parts.
- Behavior well predicted.

- Can be installed in any orientation (adding a term for gravitational energy).
- Highly accurate and can be used for a wide range of flows.
- Around 90% of pressure drop can be recovered [6].

Disadvantages

- Typically, large size.
- Expensive initial cost, installation and maintenance.
- Require long laying length. That is, the venturimeter has to be preceded by a straight pipe which is free from fittings and misalignments to avoid turbulence in flow, for satisfactory operation.
- Maintenance is complex.
- Cannot be altered for measuring pressure beyond a maximum velocity [6].

Pitot tubes

Pitot Tubes compare the free stream static pressure of a flow to the stagnation pressure which is the sum of static and dynamic pressure. Stagnation pressure is equivalent to the pressure that occurs if flow were isentropically brought to zero velocity. Because this is an isentropic process Bernoulli's equation (1) can be applied with $V_2 = 0$, P_2 equal to the measured stagnation pressure, and P_1 equal to the free stream static pressure. Knowledge of the density of the fluid enables calculation of the free stream velocity v_1 according to (4)

$$v_1 = \sqrt{\frac{2(P_2 - P_1)}{\rho}} \quad (4)$$

Advantages:

- Small
- No moving parts
- Low cost
- Low permanent pressure loss.
- Ease of installation into an existing system [10].

Disadvantages:

- Foreign material in a fluid can easily clog pitot tube and disrupt normal reading as a result.
- Low accuracy
- Poor low range ability [10].

General Advantages of Differential Pressure Flow Meters

Overall, differential pressure technology is low cost and various versions can be optimized for various fluids and goals. It has a static and robust construction with no moving part following a simple mechanism [11] [12].

General Disadvantages of Differential Pressure Flow Meters

The precision of flow measurement in the lower portion of the flow range can be degraded, due to the non-linear relationship between flow and differential pressure. One concern for many services can be plugging of the pressure piping. Purges need to be used to keep the impulse piping from plugging for slurry service.

Calibration can be issue for differential pressure transmitters, which can be influenced by the accumulation of gas or liquid in the pressure tubing. Moreover, the precision of the flow measurement system can be degraded when varying amounts of liquid can grow during operation [13] [14].

Calibration problems can be critical to the successful application of this technology. For instance, differential pressure transmitter removal for calibration reveals the transmitter to various sources of potential problems that can influence the measurement. Gas applications need to be designed precisely because changes in operating pressure and operating temperature can affect the flow measurement. It means that the gas density can change a lot during operation. As a consequence, the differential pressure generated by the flowmeter can also vary by a lot during operation [14].

Applications of Differential Pressure Flow Meters

This technology is suitable for applications including flow measurement across filters, heat exchangers, backflow preventers, pipelines, ducts and more for volume, mass flow and density measurement of liquids, gases or steam [15] [16]. Specific applications include:

- Oil and Gas flow metering in onshore, offshore and subsea applications.
- Monitoring filters in water and effluent treatment plants.
- Sprinkler Systems.
- Remote sensing of heating systems for steam or hot water.
- Pressure drops across valves can be monitored.
- Pump control monitoring.

Velocity Flow Meters

Velocity flowmeters utilize techniques that measure the velocity (v) of the flowing stream to determine the volumetric flow [17]. Velocity meters are available in different types. These include target, vortex-shedding, electromagnetic, turbine and paddle wheel, ultrasonic, and Doppler ultrasonic flow meters [18]. Because of the cost of electromagnetic and ultrasonic flow

meters, and the moving parts in turbines and paddle wheels, these approaches to flow metering are not appropriate to this research and not reviewed herein.

Target Meters

Measuring the amount of force exerted by the flowing fluid on a target is how target flow meters measure the flow. Target is suspended in the flow stream. Having a target, normally a circle or a flat disc with an extension rod, into the flow field. They after measure the drag force on the inserted target and convert it to the flow velocity. The force used on the target by the flow is proportional to the pressure drop across the target. Alike to differential pressure flowmeters, Bernoulli's equation states that the pressure drop across the target (and hence the force exerted on the target) is proportional to the square of the flow rate.

One significant advantage of the target flowmeter compare to other flowmeters is with a decent strain gauge layout, a circle drag element, and well-thought-out mathematical formulas, a target flowmeter is capable of measuring sporadic and multi-directional flows. The deflection of the target and the force bar is measured in the device [19].

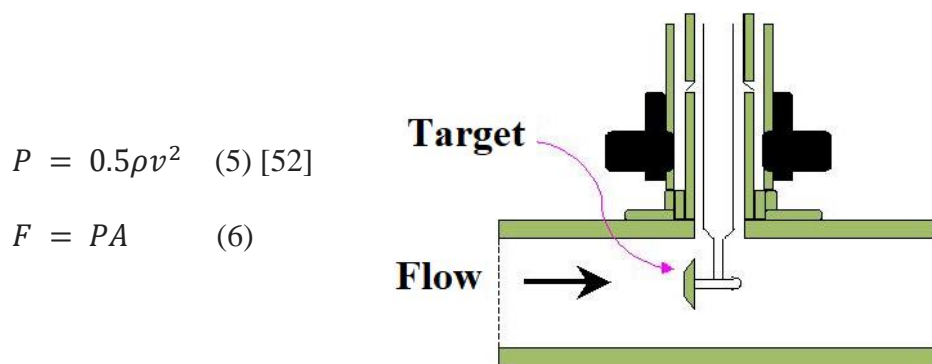

Figure 1- Target flow meter

To sense and measure forces caused by liquid impacting on a target or disk stayed in the liquid stream, target meters are used. By measuring the force used on the target, a direct observation of the liquid flow is gained [20].

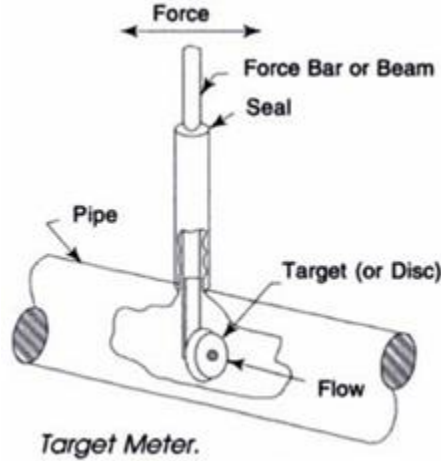

Figure 2- Target flow meter inside look [21]

The flowing fluid while passing through the pipe, develops a force on the target which is proportional to velocity head (the square of the flow). The force bar transmits this force to a force transducer (either electronic or pneumatic) to measure the force which is proportional to the square of the flow.

The relationship between the flow rate and force is expressed by the equation (7)

$$Q = K \sqrt{\Delta P} \quad (7)$$

Where

- Q = flow rate (expressed in cubic meters per hour)
- K = a known coefficient (flow factor in $\text{m}^3/\text{h}\sqrt{1\text{bar}}$, in case of water)
The K factor of a valve indicates "The water flow in m^3/h , at a pressure drop across the valve of $1 \text{ kg}/\text{cm}^2$ when the valve is completely open [22].
- ΔP = The differential pressure across the device (expressed in bar)

The target meters are available in sizes from 12.5 to 203 mm pipe diameter, and an accuracy of about $\pm 1/2\%$ with proper calibration.

The force on the target can be expressed as (8) [21]:

$$F = \frac{C_d \rho V^2 A}{2} \quad (8)$$

where

- F = force on the target (N)
- C_d = overall drag coefficient obtained from empirical data

- ρ = density of fluid (kg/m³)
- V = fluid velocity (m/s)
- A = target area (m²)

Advantages

- Useful for difficult measurements such as slurries, polymer bearing and sediment-bearing materials corrosive mixtures, etc.
- Provide good accuracy when calibrated for specific streams.
- Good repeatability.
- Good for relatively high temperatures and pressures.

Disadvantages

- In-line mounting needed.
- Limited theoretical calibration data.
- No-flow conditions must exist for zeroing [23].
- The force-balance type (i.e. target type) can handle pressures up to 1,500 psig and temperatures to 398 °C, and the strain gauge type (i.e. drag body type) can handle pressures up to 5000 psig and temperature to 315 °C.

Applications

Target meters are applied in a number of fields for measurement of liquids, vapors and gases. They are especially useful for measuring heavy viscous, dirty or corrosive fluids. Applications for target flowmeters can be found in the power, mining, pulp and paper, mineral processing, petroleum, petrochemical, and chemical industries. Common applications involve the measurement of cooling and process water flows [19].

Vortex Shedding

Vortex shedding is an oscillating flow that takes place when a fluid such as air or water flows past a bluff (as opposed to streamlined) body at certain velocities, depending on the size and shape of the body. In this flow, vortices are created at the back of the body and detach periodically from either side of the body [24]. Vortex shedding flow meters are based on the oscillating detection of vortices shed periodically from a body [25].

Advantages

- No moving parts that are vulnerable to wear
- Maintenance is not needed on a regular basis
- Liquid, stream and gas all can be measured using the vortex flow meter
- High reliability
- Long term accuracy

- Low cost of installation
- Functional across a wide temperature range
- Available for wide variety of pipe sizes

Disadvantages

- Poor accuracy or no reading at low flow rates
- needs fully developed flow for accurate readings

Applications

Vortex flow meters are suitable for measuring steam as well as a variety of liquids and gases. As fluid moves across a vortex meter shedder bar, vortices form. The frequency of the vortices shedding is proportional to the fluid velocity [26]. An example can be measuring multi-phase flow (solid particles in gas or liquid; gas bubbles in liquid; liquid droplets in gas) [27].

These types of flow meters are widely used in wastewater treatment, power generation, refinery, and chemical, industries. Vorticity flow meters can be directly connected to pipelines to work linearly with the flow rate. These units are being directly attached to the pipelines and supplied with flanges or fittings [28].

Positive Displacement Flow Meters

This flow meter type provides the highest precision in current mechanical flow meters using sealed cavities that precisely measure the actual volume of fluid passing through the meter. Different designs all capture and completely contain discrete volumes of fluid as it passes through the meter. Designs include Nutating disks, paddle wheels, oval gears, reciprocating pistons, and rotary vane meters.

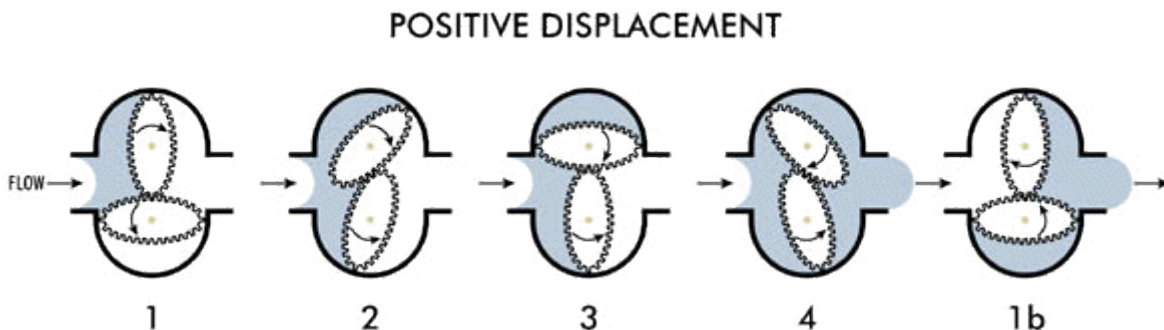

Figure 3- Positive displacement

Advantages

Positive displacement techniques provide high accuracy, long service life, low-pressure drop, self-contained operation, and low operating costs.

Disadvantages

Designs require high precision moving parts to guarantee a long service life.

Applications

Positive Displacement flow meters are commonly used to measure the flow of petrochemicals, adhesives, and paints. [18]

Mass Flow Meters

Mass flow meters are used for accurate measurement of the mass rate of a fluid. This system measures the mass rate of the flow in a pipe based on heat transfer or coriolis principles.

Thermal Flow Meters

Thermal mass flow technology measures the flow of gases directly at the molecular level, which makes it an industry standard for mass flow control of gases [29]. Thermal mass flow meters, also recognized as thermal dispersion or immersible mass flow meters include a family of devices for the measurement of the total mass flow rate of a fluid, primarily gases, flowing through closed conduits. A second type is the capillary-tube type of thermal mass flow meter. Many mass flow controllers that combine a mass flow meter, electronics, and a valve are based on this design [30]. Moreover, a thermal mass flow meter can be built by measuring temperature differential across a silicon-based MEMS chip.

Advantages

Following are the benefits or advantages of Thermal Mass Flowmeter [31]:

- It is utilized for measurement of direct gas mass flow.
- It works independent of pressure, density and viscosity.
- It offers higher accuracy.
- It has very low drop in pressure.
- Pressure and temperature compensation is not needed.
- It has large span.
- It has no moving parts.
- It is rugged in construction.
- It has short response time.
- It can be easily sterilized.

Disadvantages

Following are the drawbacks or disadvantages of Thermal Mass Flowmeter:

- It is only used for gas measurements.
- It needs inlet and outlet sections.
- Condensation of moisture in saturated gases on temperature detector will lead to low read on thermometer. Moreover, coating as well as material build up on sensor will stop the heat transfer. This causes meter to read low.
- The other sources of error in meter readings include variation in specific heat caused because of changes in composition of gas.

Applications

Below is a list of applications for thermal mass flow meter [32]:

- measuring DI Water that is commonly used in pharmaceutical industry
- Measure spray quantities of edible paints during the tablet coating process
- Measure air flow during the tablet compression stage
- Utilized in the carbonation process in beverage manufacturing
- Utilized on UHP H₂, N₂, O₂, Argon, and Silane distribution lines involved in the semiconductor manufacturing process
- Measuring carbon dioxide gas, natural gas to boilers & furnaces, flare gas, and cooling water
- Measure #2 fuel oil used to fire boilers at steam stations in creation of electricity at power plants
- Utilized in the refinery process of crude oil into a variety of petroleum products such as ethylene and propylene
- Utilized in measuring the raw materials used in chemical manufacturing same as the finished product

Coriolis Flow Meters

Coriolis mass flowmeters measure the force produced from the acceleration created by mass moving toward a center of rotation [33]. A Coriolis flow meter comprises a tube that is energized by a fixed vibration. When a fluid moves through the tube the mass flow momentum will cause a change in the tube vibration, the tube will twist resulting in a phase shift. This phase shift can be measured and a linear output derived proportional to flow [34].

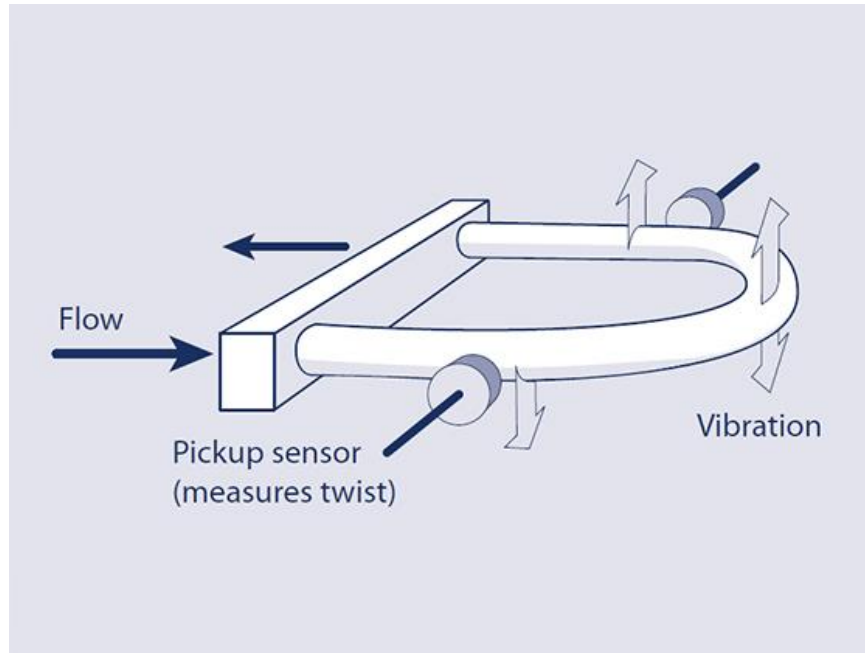

Figure 4- Schematic of a Coriolis flow sensor [34]

Advantages

- Able of measuring difficult handling fluids
- Independent of density changes, flow profile and flow turbulence. Hence straight lengths are not required.
- No routine maintenance needed since no moving parts
- High accuracy [35]

Disadvantages

- Not available for large pipes (up to 150 mm only)
- High flow velocities needed for detection resulting in high pressure drop
- Expensive compared to other flowmeters
- Difficulty in measuring low pressure gases [35]

Applications

Coriolis flowmeter equipment can be used in variety of different applications and industries to increase process efficiency, reduce downtime, and improve product quality/consistency. There is a wide use of the flowmeter in oil & gas, marine, chemical/petrochem, paints, sealants, & coatings, food & beverage, and etc.

Challenges

As previously noted, there has been a lot of effort in the past to develop different types of flow meters. Much of the focus has been on improving the accuracy of devices which has led to many high tech approaches with high precision components or complex sensing mechanisms. The increase in prevalence of sensors and the internet of things is changing the requirements of sensors and there is an emerging desire for low cost flow meters.

Objective

The goal of this work was to create a low cost, robust, static, and scaleable flow metering technology which could be easily used.

Approach

To make a reliable and accurate low cost flow meter an easy to manufacture design was pursued that would be tolerant to manufacturing variations and employ simple sensing mechanisms. This approach meant the design needed to be static, without moving parts, because of the high precision and cost of such manufacturing. Basic theory was used to analyze designs and identify ones that would have high sensitivity to flow rate and low sensitivity to geometric variation. Employing simple, low cost sensing elements was also a consideration. This also supported the use of a simple data acquisition computer to minimize that cost as well. The combination of these two approaches led to designs that combined differential pressure and target meter technologies.

Major tasks

Part selection, analytical development, and testing were the major tasks for this project. A number of components needed to go through prototyping and testing.

Part Selection

Strain gauge

The strain gauge has been in use for many years and is the fundamental sensing element for many types of sensors. There are many reasons why strain gauge is used in this project. Size, cost, simple mechanism, ease of use, and market accessibility can be considered as main reasons. Strain gauges are among the simplest sensing devices; simple ones consist of a metal foil which changes resistance when deformed. The change in resistance is due to the piezo resistive properties and change in resistivity of the material.

Wheatstone bridge

In order to measure strain with a bonded resistance strain gauge, it should be connected to an electric circuit that is able of measuring the minute changes in resistance in response to strain. Strain gauge transducers normally use four strain gauge elements electrically connected to form a Wheatstone bridge circuit [36].

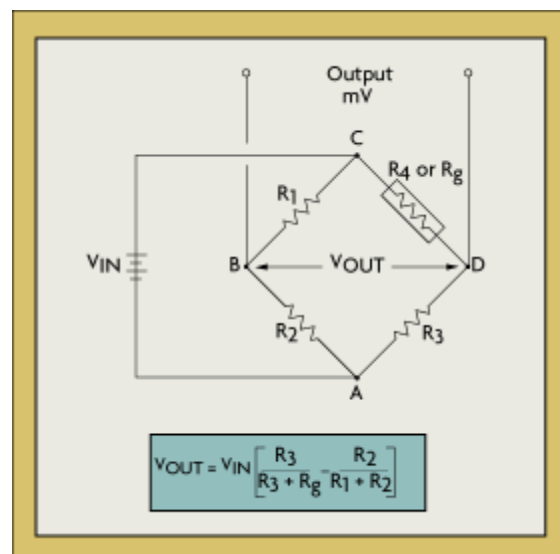

Figure 5- Wheatstone bridge [36]

If R_1 , R_2 , R_3 , and R_4 are equal, and a voltage, V_{IN} , is applied between points A and C, then the output between points B and D will show no potential difference. Although, if R_4 is changed to some value which does not equal R_1 , R_2 , and R_3 , the bridge will become unbalanced and a voltage will exist at the output terminals. The unsteady strain sensor has resistance R_g , while the other arms are fixed value resistors.

Depending on the application, the sensor can involve one, two, or four arms of the Wheatstone bridge. The total strain or output voltage of the circuit (V_{OUT}) is equal to the difference between the voltage drop across R_1 and R_4 , or R_g [36].

$$V_{OUT} = V_{CD} - V_{CB} \quad (9)$$

The bridge is considered balanced when $R_1/R_2 = R_g/R_3$ and, therefore, V_{OUT} is equal to zero. Any small change in the resistance of the sensing strain gauge will drive the bridge out of balance and ready to measure strain. When the bridge is set up so that R_g is the only active strain gauge, a small change in R_g will appear in an output voltage from the bridge [36]. If the gauge factor is GF , the strain measurement is related to the change in R_g as (10):

$$\text{Strain} = \frac{\frac{\Delta R_g}{R_g}}{GF} \quad (10)$$

Acrylic plate

Over the years, the use of high-quality acrylic has grown into many applications. Acrylic can be found in a lot of daily used products like signs, sales displays, roof windows, lenses, and screens. Also, Acrylic is approved for use within the food Industry and for constructions such as windows in submarines and fiber optics in the flat-screen TV's [37].

Some of the advantages of using acrylic sheets are below.

- Cost-effective

Synthetically manufactured, acrylic sheets are cheaper to make and purchase, hence they are an excellent alternative to glass. [38]

- Easy to laser cut

Acrylic is easy to be laser cut with low range of applied power and decent precision on the cut edges.

3 thicknesses were selected from the Acrylic plates and designs were laser cut.

Pressure sensor

Water industry is very interested in pressure drop because of pressure losses in their pipes, but it is also a measure of the force being applied to a target, because that is what causes the pressure drop. In order to that, two pressure sensors were selected to measure the pressure drop across the system for each designed plate.

As for the pressure sensor, 11 different sensors have been considered and Blue Robotics M55837 was selected for this experiment [39]. The sensor was first suggested by DOW chemical company team and after comparing with other options it received the highest points. [40]

Table 1- Pressure sensor decision matrix [40]

Pressure Sensors	Type of Sensor	Functional Principle	Max Psi		Size			Cost		Range		Accuracy			Total Weight
			Max Psi	Weight	Dimensions [mm]	Volume [mm3]	Weight	[dollars]	Weight	PSI	Weight	%	Psi	Weight	
Weight				8				5	3		8			8	
Required Spec			1200										10		
TE-MSP300	gage	strain gages & diaphragm.	15000	10	19.8 Dia x 40.64	12513.36	5	\$143.00	5	0 to 15000	10	1%	150	1	55
Amphenol-NovaSensor NPI	absolute	piezoresistiv	3000	10	13.08 Dia x 28.0	3762.38	9	\$77.88	7	0 to 3000	6	0.10%	3	10	53
Mouser Electronics-M7139	gage	X	5000	10	26.7 Dia x 31.7	17748.9	7	\$72.80	8	0 to 5000	8	0.25%	12.5	9	64
Part Number M5600-000005-05KPG	gage	X	15000	10	23.97 width 74.55	33663.6	3	\$190.40	5	0-15000	10	0.25%	37.5	5	55
Honeywell-785-MLH05KPSB01B	gage	piezoresistors & diaphragm	5000	10	27 width X 55	31490.53	4	\$142.65	7	0-5000	8	0.25%	12.5	6	59
Zoro #: G0056436	X	X	7500	10	X	X	X	\$218.33	4	0-5000	8	0.25%	12.5	6	X
Keller Preciseline-0312	sealed	X	15000	10	24 Width X 91	41167.43	2	\$632.00	3	0-15000	10	0.05%	7.5	8	45
Paine™ 210-35-010 Pressure Transducer	sealed	X	5000	10	19.12 Dia 60.19	17295.34	7	\$900.00	1	0-5000	8	0.25%	12.5	6	29
Autonics KT-302H Series	gage	Diaphragm	5000	10	55 Dia X 57	135422.27	1	\$688.00	2	0-5000	8	0.20%	9.96	7	34
Zoro #: G0056883	X	X	7500	10	X	X	X	\$179.10	6	0-5000	8	0.25%	12.5	7	X
BlueRobotics MS5837	sealed	X	435	6	10 Dia x 37	2904	10	\$68	10	0-435	5	1.30%	5.8	6	65



Figure 6- Blue Robotics Inc. [41]

One reason for being selected was the sealing type of the sensor which has a gasket that allows the sensor and the attached screw to attach to each other through the applied hole on the body of the sensor suit. The sensor is well compatible with Arduino and has low price and reasonable dimensions. This sensor has a temperature sensor accurate to $\pm 1^{\circ}\text{C}$, with data also accessible through I2C. If temperature accuracy is something to focus on.

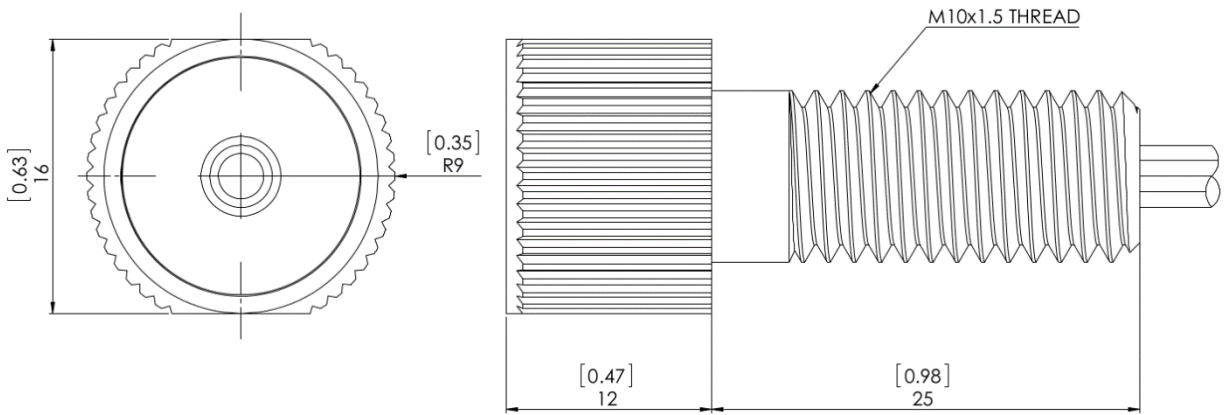

Figure 7- 2D drawing of the Blue Robotics pressure sensor [41]

Also, I2C Level Converter were used to run 3.3v logic sensors which in this research is the Bar30 and other accessories off of a 5v logic device that in this research is the Arduino Uno.

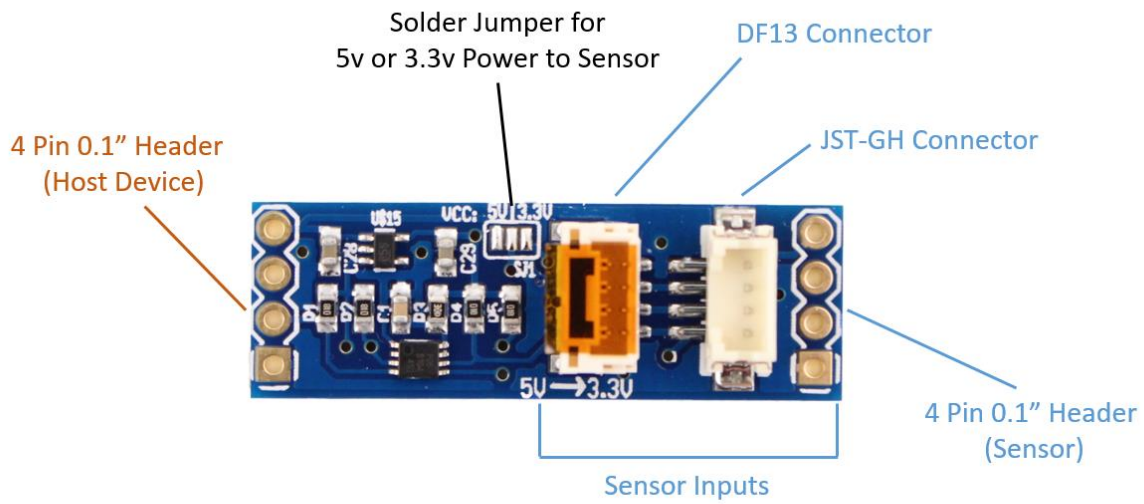

Figure 8- I2C Level Converter [42]

Data acquisition system (Arduino uno)

DAQ (Data acquisition) Device

DAQ hardware functions as the interface between a computer and signals from the outside world. DAQ essentially works as a tool that digitizes incoming analog signals, which after a computer can read them. The three key elements of a DAQ device used for measuring a signal are the analog-to-digital converter (ADC), the signal conditioning circuitry, and computer bus. Several DAQ devices comprise other uses for automating measurement processes and systems. For instance, digital I/O lines input and output digital signals, digital-to-analog converters (DACs) output analog signals, and counter/timers count and generate digital pulses. [43]

Arduino

Arduino is an open-source program which is utilized for making electronics projects. Arduino includes both a physical programmable circuit board (often called microcontroller) and a software, or IDE (Integrated Development Environment) that works on the computer, used to write and upload computer code to the physical board. Arduino was selected because:

1. It is inexpensive
2. The Arduino software runs on Windows, Macintosh OSX, and Linux operating systems [44].
3. It is well compatible with most of the electrical components.
4. This simple system ensures that low cost data acquisition will be possible with the devices.

In order to load new code onto the board, a USB cable can be used. The Arduino does not need a separate piece of hardware (called a programmer). Arduino presents a standard form part that breaks out the uses of the micro-controller into a better accessible unit. [45]

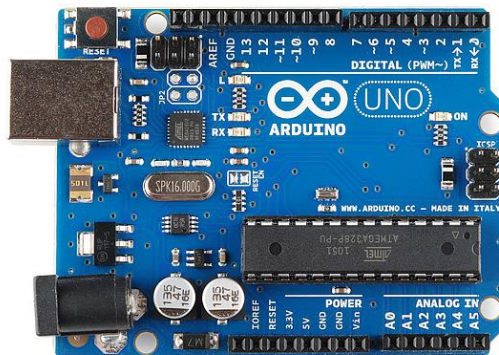

Figure 9- Arduino uno [46]

Two pressure sensors and a strain gauge were connected to an Arduino following specific Arduino programming for each.

Assembly and Testing

How to apply strain gauge on a surface?

Having all the needed materials and electronic components, the project started by designing the plates that are needed to be tested. Two basic designs were selected and based on those, two other designs were added to get a broader view of the practical design for the experiment. The base design was called hybrid target meter and was based on the beam in plate shape.

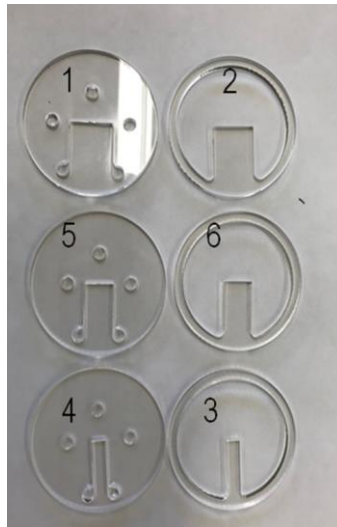

Figure 10- Primary designs

The first designs were applied on 0.125-inch-thick acrylic plate and a laser cutting machine was used to cut the plate. Strain gauges were mounted on the root of the plate. The reason for mounting strain gauge on the root was to capture the highest amount of resistivity from strain gauge because the root of the plate was where the plate was subjected to the highest amount of bending from the applied force by water flow. Applying and sticking strain gauge follows some specific and delicate procedure. The installation of a strain gauge to a specimen is probably the most critical, yet least emphasized step in the strain measurement. An improper installation may seriously degrade or even completely mess up the validity of a test. Certain types of strain gages can be welded on the surface of surface. However, adhesives are still the most commonly used agents for mounting strain gages.

The tape-assisted installation method is the most popular method to install metal-foil strain gages. Its procedures can be summarized as follows. [47]

- Surface preparation
- Gage Bonding
- Lead wire Attachment
- Protective Coating

A very thin layer of epoxy was applied on the surface of the strain gauge to act as a protective layer. The main reason for this was to make the strain gauge waterproof.

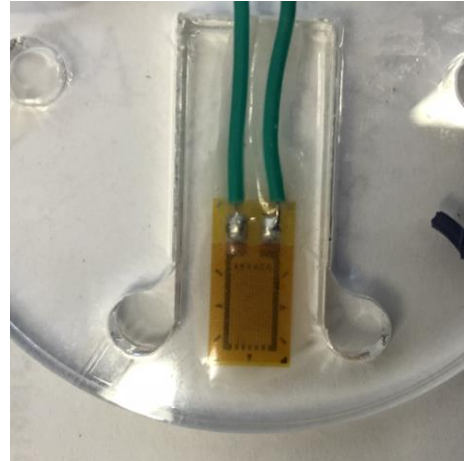
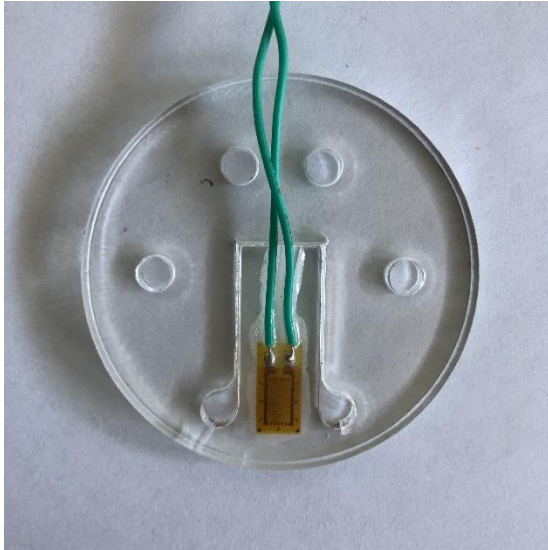

Figure 11- Mounted strain gauge on the beam of the Acrylic plate

Two holes were made on the testing pipe, before and after the testing plate, to measure the pressure of the water before and after the flow sensing mechanism. As mentioned before, water industry is very interested in pressure drop in their systems and pressure sensors were used in the system to measure the amount of drop in the water pressure.

Testing was done in the advanced Badger Meter laboratory at the global water center building in Milwaukee, WI. The testing setup consisted of an automatic screen controlled pump, adjustable piping facility, electromagnetic flow meter, water circulating tanks and a safe mode device to control the pump applied pressure based on the chosen pipe diameter.



Figure 12- Electromagnetic flow meter



Figure 13- Pump



Figure 14- Pump's safe mode controller

The plate was set inside a test setup equipped with a pipe joint, which was made to ease the process, increase the speed of testing, and improve testing safety and accuracy. The piping setup was placed in line with the piping facility which was connected to the pump and controller to adjust the amount of flow.

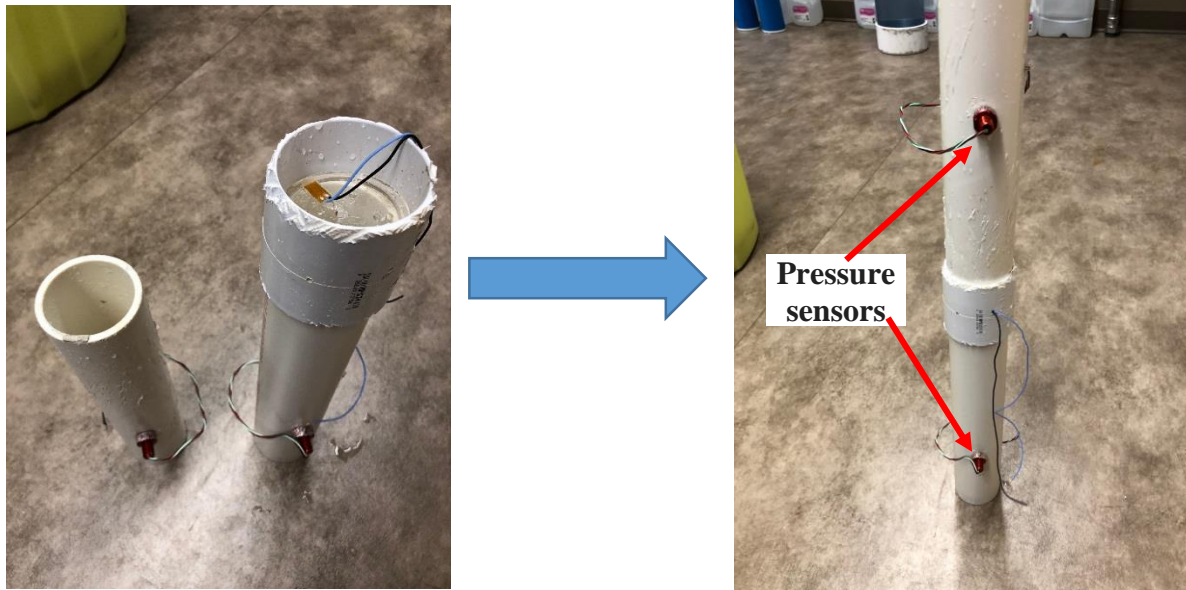

Figure 15- Testing pipes and the joint

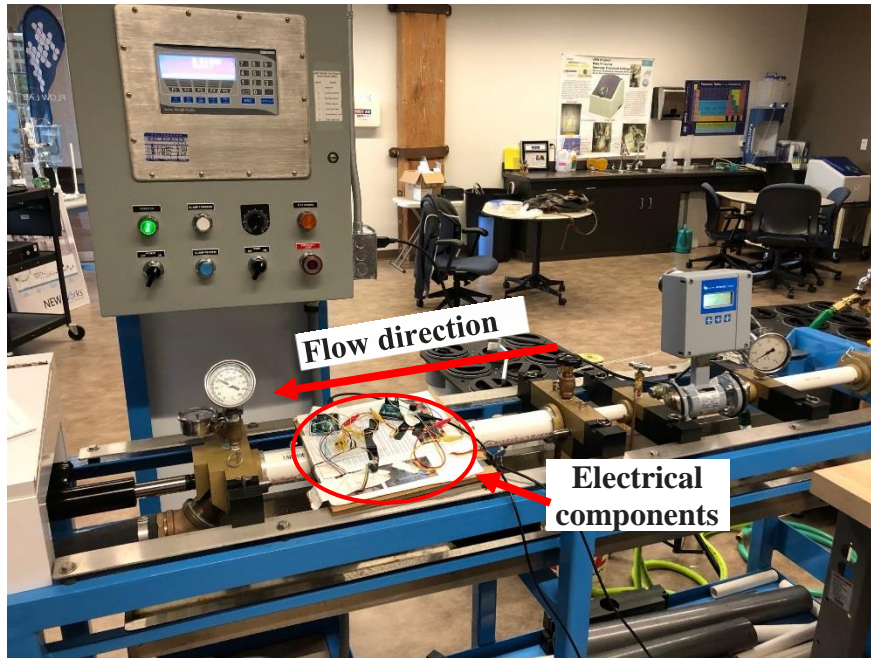

Figure 16- Testing setup

Factorial analysis was used to identify correlations between and among variables to bind them into one underlying factor driving their values. As shown in the tables at the appendix, 63 plates were built by following three main designs and changing three variables (length, width, thickness) for each design to study the impact of each variable on the results. The setup was waterproofed using a pipe joint and two gaskets to make sure there was no potential leak due to the high flow rate. The trend each test followed was to start with an initial zero flow and measure the strain from the mounted strain gauge, and then increase the flow to 10, 21, 37, 60, 80 and 90 (liters per minute) for all plates consecutively. Plate designs underwent repeated testing and results were averaged.

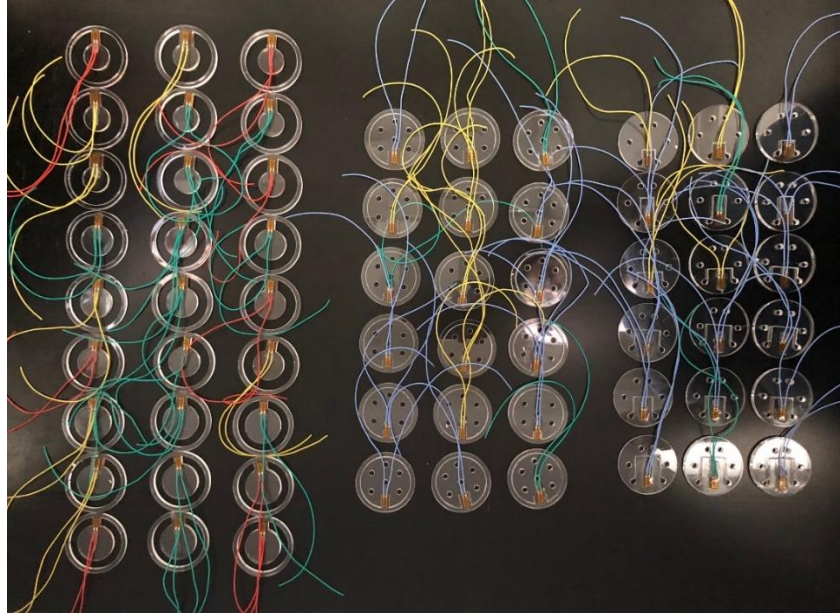

Figure 17- Testing plates

The mentioned trend was used for all the 63 plates and data was collected using an Arduino uno. During each strain measurement for each plate, pressure was also measured before and after plate bending to capture the amount of pressure drop from each plate. Additionally, another Arduino uno was used to measure the data from pressure sensors. It should be mentioned that captured data from strain gauges and pressure sensors were all monitored by the same software which was connected to both Arduinos. Measurements for simultaneous strain and pressure were taken with no time gap between the testing levels.

A number of failures were reported in the testing procedure due to the following reasons:

- Breaking at the root of the beam due to high flow rates and a large applied force to the plate's beam.
- High flow in some cases lead to the removal of the epoxy cover layer from the strain gauge.
- Soldering failure of the wires and strain gauge
- Wires broken in some plates due to applied force from the piping setup
- Epoxy penetration into the grooves of the cut beam and leading to a stiff/non-movable plate
- Bad strain gauge mounting which could be caused by low amount of glue or applied force.

It should be mentioned that prior to starting the data acquisition for each plate, there was a gap of 10 minutes prior to measuring the first data points, in order to make sure there would be no data error due to temperature compensation. All the measured data for each plate was compiled into a table with all the related details including the variable term sizes, actual applied flow rates, pressure before and after, pressure drop number, resistance average, and measured strain. Moreover, each table has flow charts which show the strain in respect to actual flow rate, actual flow rate in respect to measured pressure drop, and actual flow rate in respect to measured strain.

Fundamental equations

In the early stages after gathering all the needed materials and electronic components, the project started by designing the plates. Two basic designs were selected and based on those, a third design was added to get a broader view of the practical design for the experiment. Pressure differential was measured across the target plate and beams of varying width, length, and thickness were tested to determine the effect of each parameter in the measured strain.

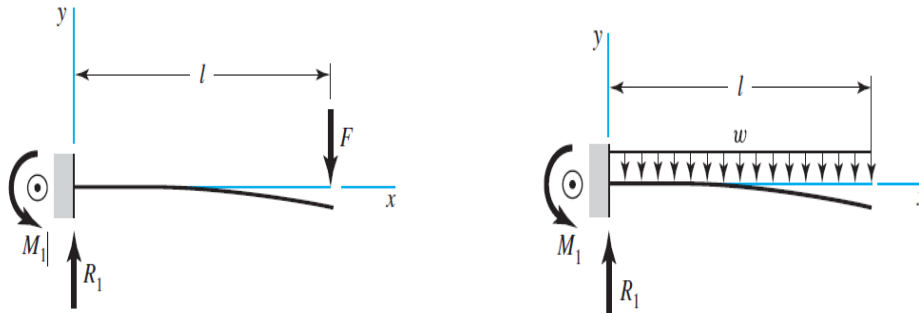

Figure 18- Bending parameters of beam [51]

Moment is:

$$M = Fl \quad (11)$$

Where l is length of the beam.

$$M = \frac{wl \times l}{2} \quad (12)$$

Force is:

$$F = PA$$

The dynamic pressure is defined as:

$$P = 0.5\rho v^2$$

Where:

- ρ = fluid density
- v = fluid velocity

The second moment of area of a cantilever beam with uniform rectangular cross-sectional area is:

$$I = \frac{wt^2}{12} \quad (13) [48]$$

With w denoting the width of the cross-sectional area and t is the thickness of the plate.

The maximum bending stress is:

$$\sigma = \frac{Mc}{I} \quad (14) [49]$$

c is the perpendicular distance from the outermost fiber to the neutral axis and is equal to $t/2$.

$$\sigma = \frac{Mt}{2I} \quad (15)$$

And based on Hooke's law for tensile loading, tensile strain is equal to the beam bending stress over young's modulus:

$$\sigma = \frac{\epsilon}{E} \quad (16) [50]$$

Designs

Based on the initial testing results three main designs were created.

- 1- Classic target meter
- 2- Hybrid target meter
- 3- Hybrid cantilevered meter

Classic target meter

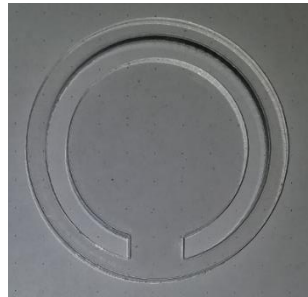

Figure 19- Classic target meter

As the name displays, this design has a circular flat target plate which is connected to the rest of the plate. As water flows, it hits the circular target area and the force which is applied by water cause a pressure that bends the plate from the beam where it is connected to the plate. Maximum strength captured from bending is caused at the root of the beam where strain gauge is mounted.

Deriving the equations for Classic target meter

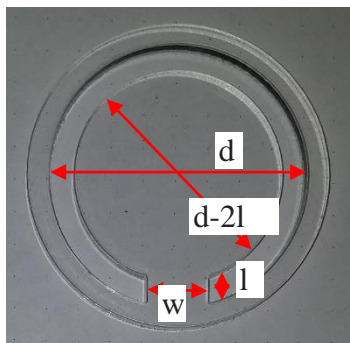

Figure 20- Classic target meter

Area of the circular target plate is:

$$\left[\frac{d-2l}{2}\right]^2\pi \quad (17)$$

P is the dynamic pressure across the plate, A is the surface area on which the pressure is applied, and F is the net force due to the applied water pressure, modeled as a point force at each plate's respective centroid based on equation 6.

The effective surface area for the plate is the area of the circular target plate plus the area of the beam which connects that to the rest of the plate. The effective surface area for the plate was calculated:

$$A = \pi r^2 \quad (18)$$

r is the radius of the target beam and base on the equation 11, 5, and 16, replacing pressure and area with the following derived equations, leads to:

$$F = PA = (0.5\rho v^2) (\pi r^2)$$

$$F = \frac{\rho v^2 \pi r^2}{2} \quad (19)$$

Length of the moment arm is equal to the radius of the plate. Therefore:

$$M = Fr$$

Substituting the second moment of area equation into the tensile stress equation gives:

$$\sigma = \frac{6M}{wt^2} \quad (20)$$

$$\epsilon = \frac{6M}{wt^2E} \quad (21)$$

To measure the length of the moment arm to the centroid, the area of the whole plate was taken, minus the area of the circular groove around the target beam. The base of the moment arm taken to be at outer radius d, following the equation 17.

$$F = PA = (0.5\rho v^2) \left[\left(\frac{\pi}{4} \times \frac{d-2l}{2} \times \frac{d}{2} + \frac{wl^2}{2}\right)\right] \quad (22)$$

Putting the equation 22 in the equation 11, leads to:

$$\varepsilon = \frac{3\rho V^2}{Ewt^2} \left[\pi \left(\frac{d^4}{8} - \frac{d^2l}{2} + \frac{dl^2}{2} \right) + \frac{wl^2}{2} \right] \quad (23)$$

Key terms are: l, t, w

$$v = \sqrt{\frac{\varepsilon Ewt^2}{3\rho \left[\pi \left(\frac{d^4}{8} - \frac{d^2l}{2} + \frac{dl^2}{2} \right) + \frac{wl^2}{2} \right]}} \quad (24)$$

- ε = strain
- ρ = fluid density
- V = fluid velocity
- E = young's modulus
- t = plate thickness
- l = beam length
- w = beam width
- r = plate radius
- d = pipe diameter

Three key terms were selected to be considered as the variables, based on the derived equation. These variables were applied on the designs and a testing table was made for each design based on them. One common variable term between all three designed plates is the thicknesses of the cut plates which are 0.125, 0.1875, and 0.25 inch. For a classic target meter, three lengths (0.3, 0.4, 0.5 inch) and three widths (0.3, 0.4, 0.5 inch) of the beam were also the studied variables. One main reason for going through the testing procedure was to consider and study the effect of each testing parameter on the final results. In order to that, an equation was derived for each plate based on the shape of the plate and applied stress on the target plate part, and key terms were selected to be tested and evaluated throughout the testing procedure.

Equation 13 reveals that strain is proportional to thickness, width, and length of the beam. Increasing the length of the beam, should cause an increase in the measured strain, based on the derived equation. Also, increasing the width should have the opposite effect. Since the thickness is powered by two, the effect is expected to be more compared to the other two parameters.

Hybrid target meter



Figure 21- Hybrid target meter

This design has a rectangular cut flat target plate in the middle of the plate which bends from its root when it is under pressure inside the system. As water flows, it hits the rectangular target area and the force which is applied by water cause a pressure that bends the plate from the beam where it is connected to the plate. Maximum strength captured from bending is caused at the root of the beam where strain gauge is mounted.

Deriving the equations for Hybrid target meter

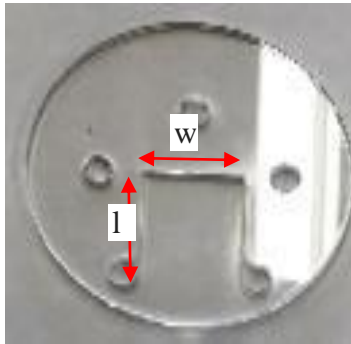

Figure 22- Hybrid target meter

The Hybrid target meter equations for applied force, follow the same basic assumptions as the classic target meter, force is equal to applied pressure multiplied by surface area.

The target surface area is equal to the distance between the applied force point and the beam root multiplied by the width of the beam. Therefore, the area of the rectangular beam is:

$$A = lw \quad (25)$$

Replacing pressure and area with assumptions from the derived equation leads to:

$$F = (0.5\rho v^2) (lw) \quad (26)$$

Based on equation 11 and Figure 18, the bending moment of the beam, for the Hybrid target meter is taken to be located at the beam's midpoint, with the beam's full length measured from the inner radius to the end of the rectangular beam area. The center of the applied force to the beam would be the distance from the root the beam to the center point of the beam, where the plate's centroid is located.

$$M = Fl'$$

$$l' = l/2$$

$$M = \frac{Fl}{2}$$

Based on the above equations and equation 16 and 20, below derivation is achieved.

$$\sigma = \frac{6Fl}{2wt^2E} \quad (27)$$

$$\frac{6Fl}{2wt^2E} = \frac{6\rho v^2 l^2 w}{4wt^2E}$$

$$\varepsilon = \frac{3\rho V^2 l^2}{2Et^2} \quad (28)$$

$$V = \sqrt{\frac{2\varepsilon Et^2}{3\rho l^2}} \quad (29)$$

Key terms are: l, t, w (cancels)

Three key terms were selected to be considered as the variables and based on the derived equation, width of the beam got cancels out of the effective parameters. These variables were used to determine the designs, and a testing table was made for each design based on the changing variables. For the Hybrid target meter, based on the derived equation width cancels out, and only length and thickness of the cut plate were studied. One thing studied during the testing was to confirm that the effect of the plate thickness is negligible based on the derived equation.

Considering the equation, increasing the length of the beam, should result in the increase of the measured strain. The opposite is true for the thickness of the plate. Both thickness and length, are powered by two which means the effect of each should be significant.

Hybrid cantilevered meter

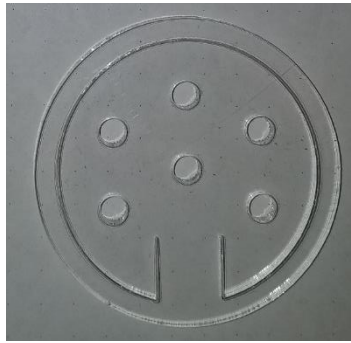

Figure 23- Hybrid cantilevered meter

This design has a circular flat target plate which has the diameter of the pipe that it is going to be used in. There are 6 circular cut holes on the target area to reduce the pressure drop across the plate. The same as the other two designs, when water flows, it hits the circular target area and the force which is applied by water cause a pressure that bends the plate from the beam where it is connected to the plate. Maximum strength captured from bending is caused at the root of the beam where strain gauge is mounted.

Deriving the equation for Hybrid cantilevered meter

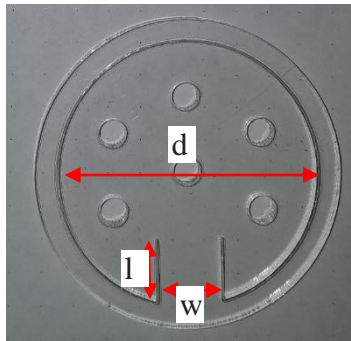

Figure 24- Hybrid cantilevered meter

To measure the centroid where the point force is modeled, the area of the whole plate minus the summation of the area of the six circular cuts should be calculated. The same trend as the other plates used to measure the strain.

The distance from root to the force center point is

$$l = \frac{d}{2}$$

$$\text{Effective area} = \pi \left(\frac{d}{2}\right)^2 - A_h \quad (30)$$

Which A_h is the summation of the area of the six circular cuts.

$$\epsilon = \frac{6M}{Ewt^2}$$

$$\epsilon = \frac{3\rho V^2 \frac{d}{2} \left(\pi \left(\frac{d}{2}\right)^2 - A_h \right)}{Ewt^2} \quad (31)$$

Key Terms are: l (cancels), t, w

$$V = \sqrt{\frac{\epsilon Ewt^2}{3\rho \frac{d}{2} \left(\pi \left(\frac{d}{2}\right)^2 - A_h \right)}} \quad (32)$$

Three key terms were selected to be considered as the variables and based on the derived equation for Hybrid cantilevered meter, length of the beam got cancels out. These variables were used to determine the designs, and a testing table was made for each design based on the changing variables. For the Hybrid Cantilevered design, based on the derived equation length of the beam cancels out and only width and thickness of the cut plate were studied. One thing studied during the testing was to confirm that the effect of the beam length is negligible and confirm that there is a good match between the theory and the experiment.

Considering the equation, increase in the flow rate which is powered by two, should result in increase in the measured strain. Thickness is also powered by two in the denominator and should have a significant effect in the measured strain.

Results

Electromagnetic flow meter and mass measurement were used to measure the applied flow rate. Data was collected with a simple data acquisition system based on pressure differential and strain based systems. Two pressure sensors were used to measure the pressure drop across the built-in sensors. After analyzing the captured data from all the designed plates, the results below were presented for each design.

Pressure drop and Strain vs. Flow rate

Classic target meter

In figure 25, each dot shows the average pressure drop for each plate. Plates were tested for varied applied flow rates, and the results of 3 trails for each flow rate were averaged. The graph's trend is somewhat variable. However, the obvious trend is that by generally by having a higher flow rate, the plate displacement due to pressure increases.

It should be noted that the pressure drop in a classic target meter plate is very low compared to other two designs. The reason for not getting consistently accurate and reasonable pressure drop numbers was due to the shape of the design and very low amount of plate displacement, even during very high flow rates. Also, based on the accuracy and range of the pressure sensor (page 18), the captured data was too low and could not be exactly measured.

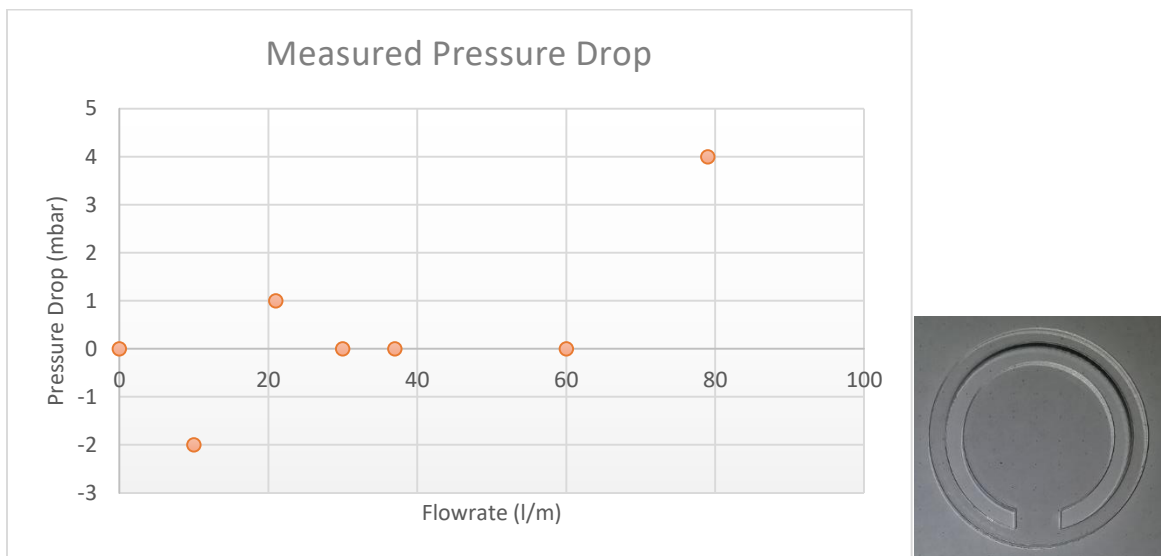

Figure 25- Pressure drop vs Flowrate for Classic target meter plate

Figure 26 shows the strain vs. flow rate. The blue dots illustrate the measured average strain for each plate versus the applied flow rate. Flow rate is measured by an electromagnetic flow meter

and has an actual number and the strain is measured by strain gauge and the connected Arduino for DAQ. As mentioned before, pressure increment testing for each plate was repeated 3 times for each flow rate, and the presented number is the average. There is an error bar for every strain calculation which shows the range of the measured strain during each testing for every flow rate. For the classic target meter, as shown in figure 33, the graph generally is following an upward trend which is expected, and by increasing the flow rate, strain also increased. Also the trend follows a second order curve which is because of having strain as a function of velocity squared based on the derived equation. In that case by increasing the velocity, the second order curve was captured which is ideal. The experiment yielded a range of 0.0004 for the measured strain number.

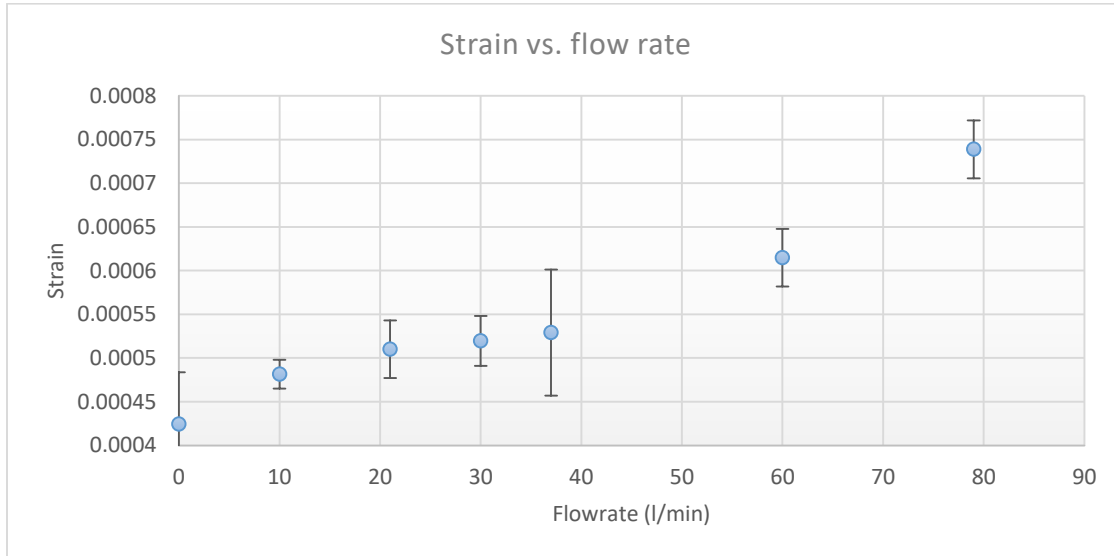

Figure 26- Strain vs. flow rate for classic target meter plate

Hybrid target meter

As shown, measured pressure drop and plate displacement increases with the amount of applied flow rate. The results of this plate show an upward trend. It should be mentioned that the pressure drop range was ~200 mbar which is significantly higher when compared to the classic target meter plate. The main reason for the difference was due to the design of the plate, specifically the larger “beam” surface area of the hybrid target meter design when compared to classic target meter.

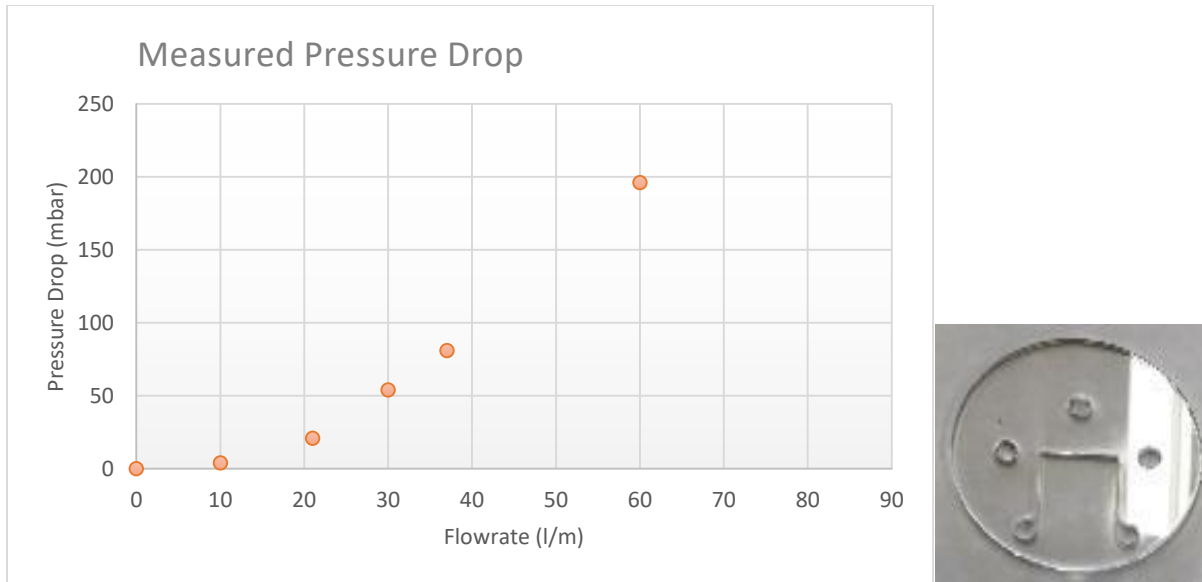

Figure 27- Pressure drop vs flow rate in hybrid target meter plate

Figure 28 shows the average measured strain number versus the applied flow rate. As expected, by increasing the flow rate, the amount of measured strain from strain gauge. The graph generally is following an upward trend which is expected, and by increasing the flow rate, strain also increased. Also the trend follows a second order curve which is because of having strain as a function of velocity squared based on the derived equation. In that case by increasing the velocity, the second order curve was captured which is ideal. The error bar is shown for each measured strain and the strain range is ~ 0.0016 , which is a magnitude of 4 larger than the classic target meter.

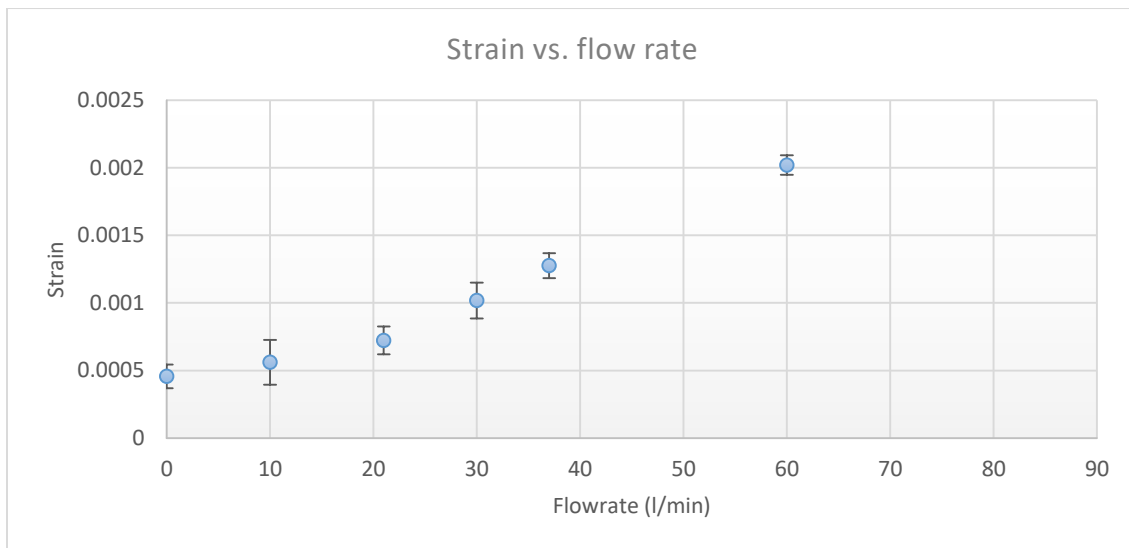

Figure 28- Strain vs flow rate in hybrid target meter plate

Hybrid cantilevered meter

As expected, the pressure drop follows an upward trend with increase in the applied flow rate. The pressure drop range is almost ~500 mbar which is more than the other two designs. The graph trends upward, and by increasing the amount of applied flow rate, the measured strain increased.

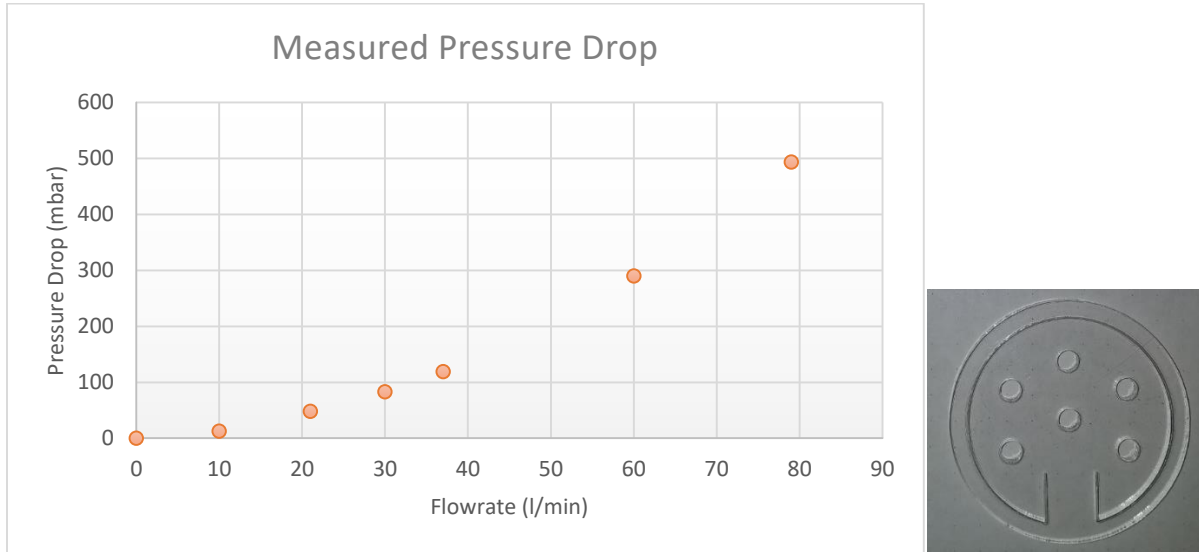

Figure 29- Pressure drop vs flowrate for hybrid Cantilevered plate

Figure 30 illustrates the strain versus applied flow rate, and shows an upward trend for the graph which is expected. By increasing the flow rate, strain also increased. Moreover, the trend follows a second order curve which is because of having strain as a function of velocity squared based on the derived equation. In that case by increasing the velocity, the second order curve was captured which is ideal. As expected, an increase in the amount of applied flow rate, caused an increase in the amount measured strain for each flow rate. The strain range for the hybrid Cantilevered plate is almost the same as the hybrid target meter.

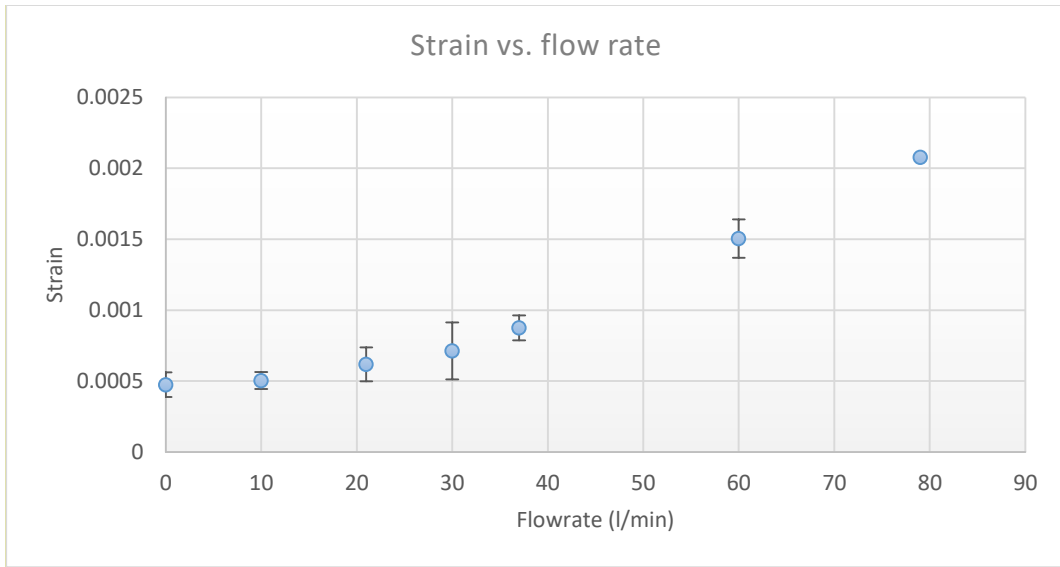

Figure 30- Strain vs flow rate for hybrid Cantilevered plate

Factorial Analysis

Classic target meter

Considering the effect of each studied parameter, results are shown in the “Pareto chart of the standardized effects” below. The purpose is to illustrate the effect of thickness, length, and width on the measured results, and apply the derived equation to compare the effect of each from theory to experiment. As shown in figure 31, thickness has the most significant effect on the results. The beam length for a classic target meter has the lowest effect based on the testing and experiment. Moreover, flow rate effect is low which is an issue in this design since the goal is to detect flow rate inside the pipe.

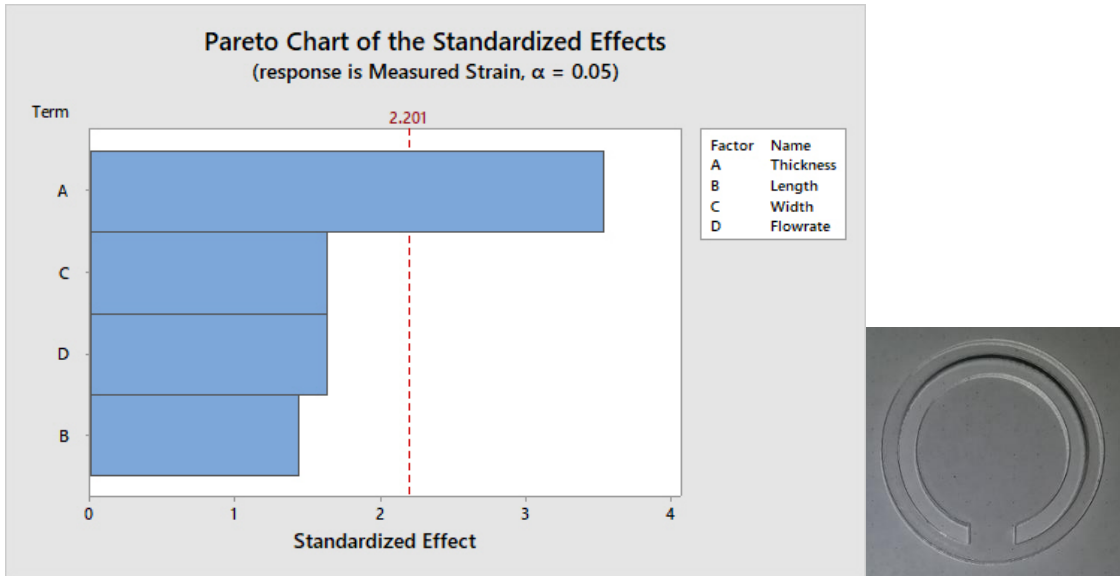

Figure 31- Pareto chart of the standardized effects of classic target meter design

Figure 32 illustrates the effect of each studied parameter, as well the interaction of every parameter with another parameter based on the multi-level factorial analysis. Considering the chart, AB (the interaction between thickness and length) and AD, (the interaction between thickness and flowrate), show the highest effect on the results. The most significant effect was due to the thickness of the plate and least significant effect comes from the interaction of the length, width, and flow rate.

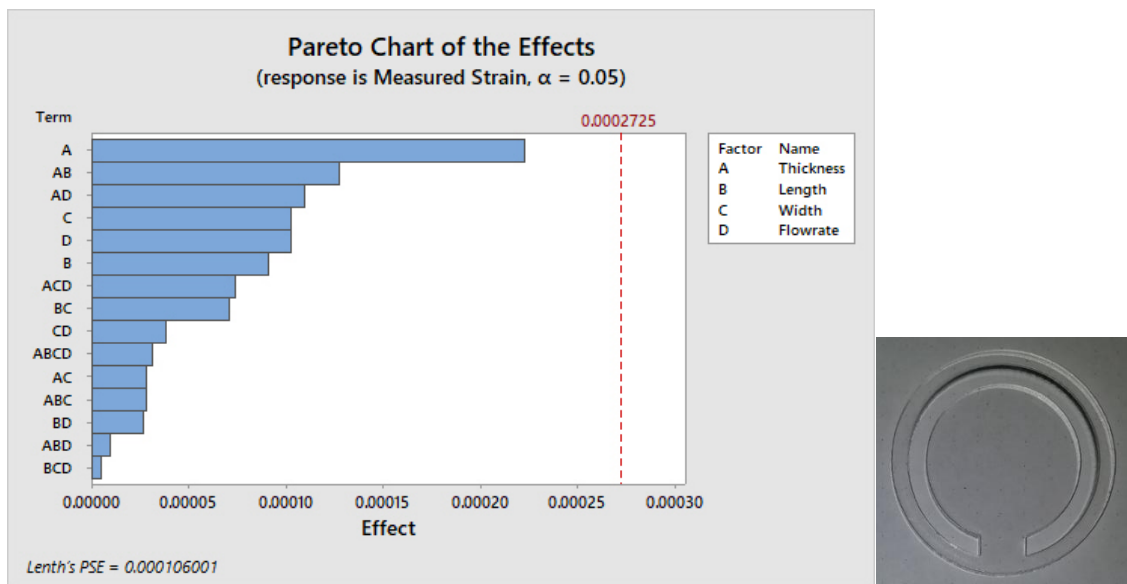

Figure 32- Pareto chart of the effects of the classic target meter design

Hybrid target meter

Figure 33 illustrates the standardized effect of each studied parameter. As shown, thickness has the most significant effect. Flow rate and length of the beam have the same effect on the results. Flow rate effect Moved up compare to classic target meter which is considered good for a flow rate sensor. As expected, the width of the beam displays the lowest effect as this term cancels in the derived equation for hybrid target meter and this illustrates that there is a good match between the derived theory and the results from the experiment.

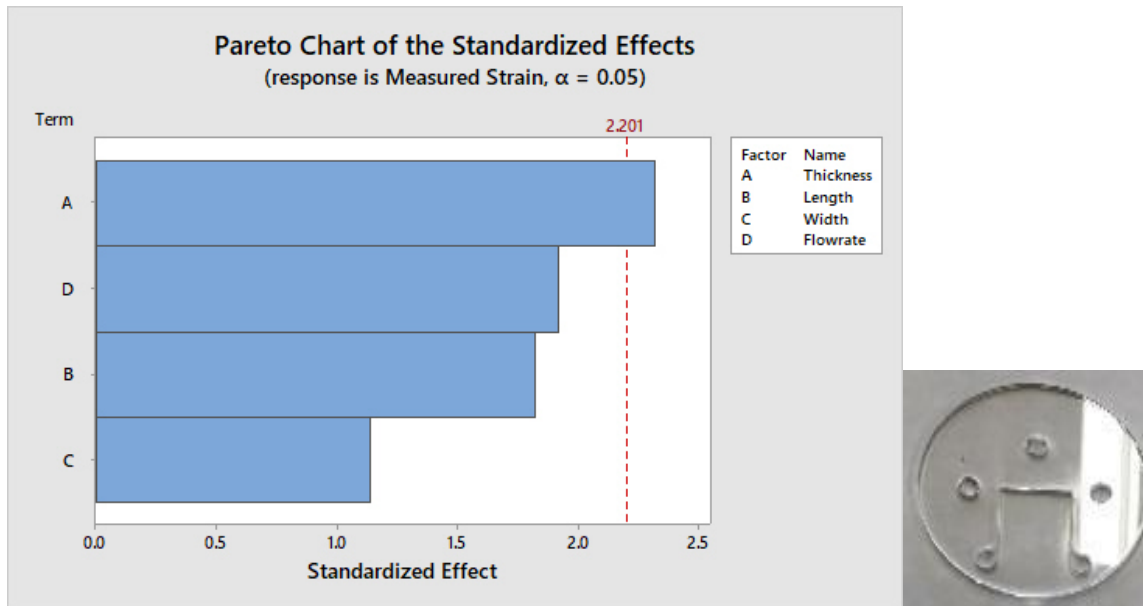

Figure 33- Pareto chart of the standardized effects of the hybrid target meter design

Thickness of the plate for the hybrid target meter design has the most significant effect on the results. Interaction of each parameter with the other is shown in figure 34. As shown, interaction of the width and flow rate has the lowest effect on the final results.

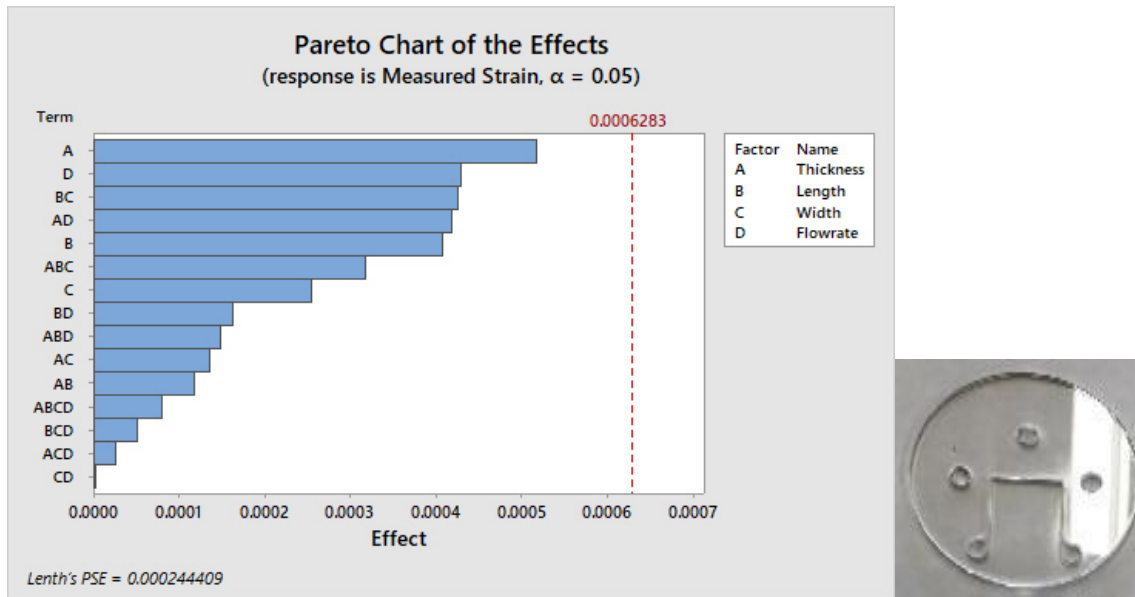

Figure 34- Pareto chart of the effects of the hybrid target meter design

Hybrid Cantilevered meter

Studying the effect of each target parameter on the results shows that the flow rate has the most significant effect and that represent the best flow rate sensor among the tested designs. Moreover, the length of the beam has the least effect as was supposed to base on the derived equation which the length got canceled out. Thickness also plays an important role in the results. The effect of the width of beam is low compare to the other parameters.

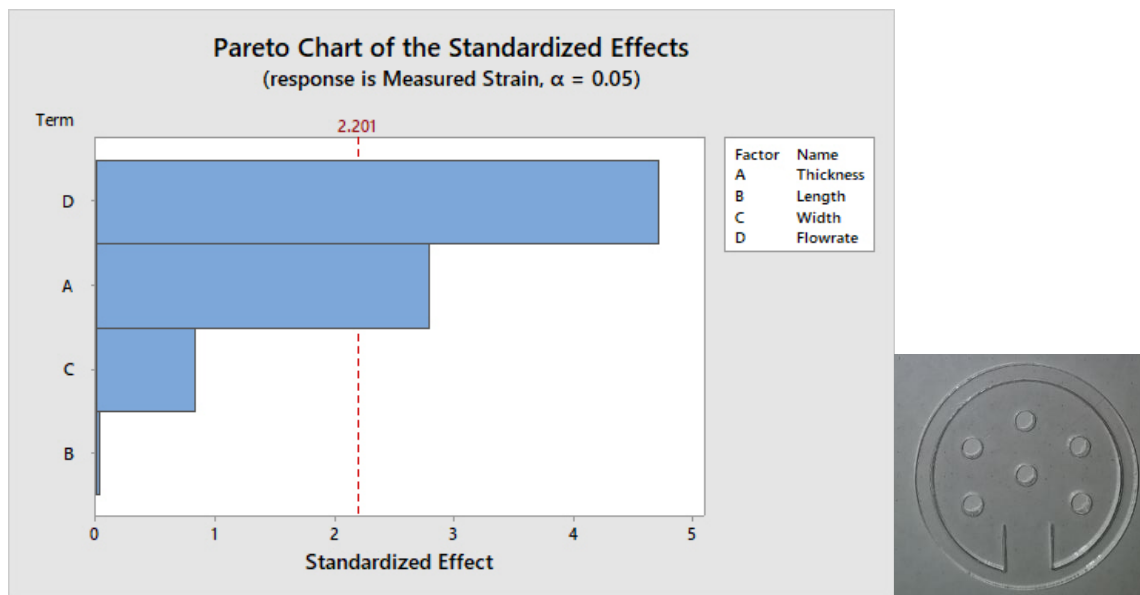

Figure 35- Pareto chart of the standardized effects for the hybrid cantilevered design

Considering the figure 35, as expected based on the derived equation for cantilevered plate, the length of the beam has the lowest effect on the measured results and gets cancel out from the effective parameters.

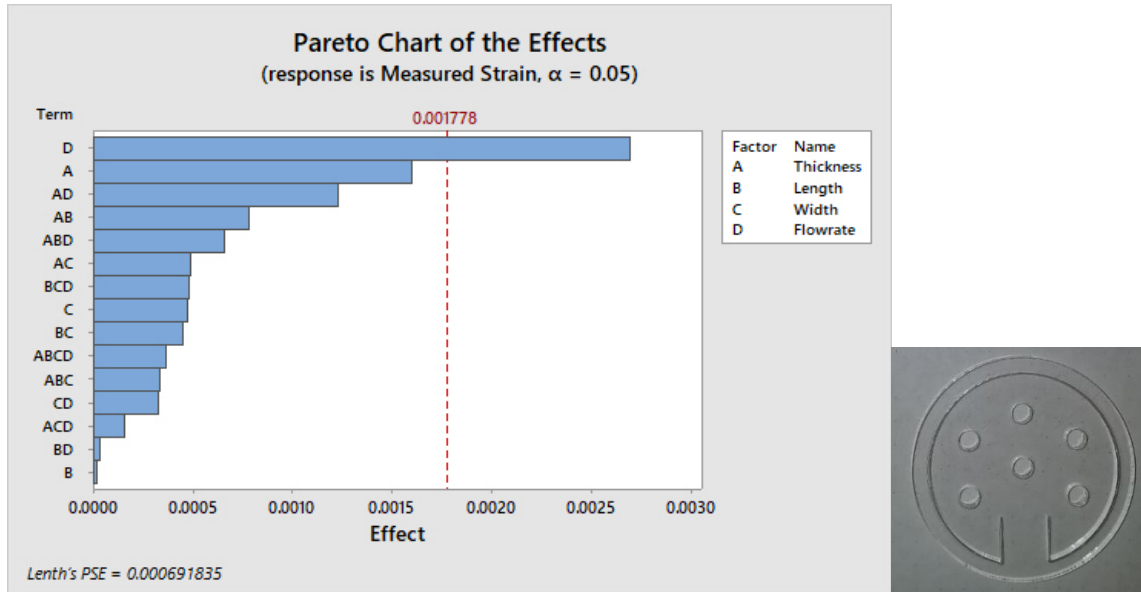

Figure 36- Pareto chart of the effects for the hybrid cantilevered design

In the cantilevered plate, the flow rate has the highest effect compare to the other two designs and also increase in the flow rate shows a better neat upward trend of the measured strain. Cantilevered design illustrated more accurate results when compared to the other designs and there is more room to improve upon the design and effective parameters, to make a more sensible and precise model.

Conclusions

Beam bending was a critical component to all the designs created.

Analysis of the equations and experimental results provided information about which parameters most effected the sensitivity of each sensor design. The sensitivity of the classic target meter was most effected by thickness, followed by width, flowrate, and length. This indicates that such designs are very dependent on design and manufacturing parameters which is undesirable for the objectives of this work. The sensitivity of the beam in plate design was most effected by thickness, followed by flow rate and length. This design showed almost no change in sensitivity due to variation in beam width. Combined this shows improved sensitivity to variation in flow rates and tolerance to potential manufacturing variations in the beam width. Finally, the sensitivity cantilevered plate design was most effected by flow rate, followed by thickness and width. This design showed almost no change in sensitivity due to variation in beam length. Combined this shows the highest sensitivity to variation in flow rates and tolerance to potential manufacturing variations in the beam length. These results indicate that the cantilevered plate design is the best for sensing flow rate while being inert to manufacturing error.

Across all designs, the manufacturing parameter of beam thickness was found to be very important. While the order of the sensitive parameters matches well between equations and experimental results, the magnitudes of measured strain relative to the other parameters was significantly off. This is likely due to the simple models and assumptions used for fluid structure interactions and flows.

The demand for a low cost and scalable flow metering technology is growing, and this sensing technology can fill the need for many consumer, academic, and industrial projects. Future work for related technology can focus on metering flow for low flow rate and smaller pipes for leak detection use or any applications involving water dispensing.

References

- [1] Shekhter, Yu.L., "Flow metering," Institute of High Temperatures USSR Academy of Sciences, Moscow, 2015.
- [2] UNICEF, "Progress on sanitation and drinking water," World health organization, 2015.
- [3] Forbes Media LLC, "<https://www.forbes.com>," Forbes Media , 2018. [Online]. Available: <https://www.forbes.com/sites/jamesconca/2018/07/11/the-global-clean-water-crisis-pepsico-expands-its-safe-water-program/#2e2ef4d81d12>.
- [4] MARIBEL PEREZ WADSWORTH, "U.S. drought at worst level in nearly 4 years," USA TODAY, McLean, VA, 2018.
- [5] World Health Organization, "Water Safety in Distribution Systems," WHO Document Production Services, Geneva, Switzerland, 2014.
- [6] Wikipedia distributor, "<https://ipfs.io>," IPFS, [Online]. Available: https://ipfs.io/ipfs/QmXoyvizjW3WknFiJnKLwHCnL72vedxjQkDDP1mXWo6uco/wiki/Advantages_and_disadvantages_of_orifice_meter_and_venturi_meter.html.
- [7] F. M. White, Fluid Mechanics, 4th edition, Boston: McGraw-Hill, 1999.
- [8] D. W. Spitzer, Industrial Flow Measurement 3rd Edition, 3rd ed., ISA – The Instrumentation, Systems, and Automation Society, 2005.
- [9] J. D. Anderson, Fundamentals of Aerodynamics 5th Edition, New York: McGraw-Hill, 2011.
- [10] Automation forum, "<https://automationforum.co>," Automation forum, 31 1 2018. [Online]. Available: <https://automationforum.co/pitot-tube-working-advantages-disadvantages/>.
- [11] National measurement institute, OIML R49 – Water meters intended for the metering of cold potable water and hot water., Lindfield: Commonwealth of Australia, 2015.
- [12] denizen robo, "Differential Pressure flow measurement – How it works ? Advantages and Disadvantages of DP flow measurement," Automation forum, 2015.
- [13] GoichiMatsui, "Identification of flow regimes in vertical gas-liquid two-phase flow using differential pressure fluctuations," *International Journal of Multiphase Flow*, vol. 10, no. 6, pp. 711-719, 1984.
- [14] G. Y. -. K.-W. Inc, "Differential pressure flow meters". USA Patent US3745826A, 14 6 1971.
- [15] Fuji electric instrumentation and control, "Coulton.com," Fuji electric, 2016. [Online]. Available: https://www.coulton.com/beginners_guide_to_differential_pressure_transmitters.html.
- [16] Badger meter co., "badgermeter.com," Badger meter , 2018. [Online]. Available: <https://www.badgermeter.com/technologies/differential-pressure-flow-meters/>.
- [17] Erik and Lars Rosaen, "<http://www.flowmeters.com>," Universal flow monitors(UFM), [Online]. Available: <http://www.flowmeters.com/how-flowmeters-work>.

- [18] Industrial Dynamics Inc., "<http://www.industrialdynamics.com>," Industrial Dynamics Inc., 2017. [Online]. Available: <http://www.industrialdynamics.com/blog/types-of-the-flow-meters/>.
- [19] Universal flow monitors, "<http://www.flowmeters.com>," UFM, [Online]. Available: <http://www.flowmeters.com/target-for-clean-water>.
- [20] R. C. Baker, *Flow Measurement Handbook*, Cambridge: Cambridge University Press, 2016.
- [21] Instrumentation forum, "<https://instrumentationforum.com>," Instrumentation forum, [Online]. Available: <https://instrumentationforum.com/t/explain-about-target-flow-meter/5370>.
- [22] Wikipedia, "<https://en.wikipedia.org>," Wikipedia, 18 12 2018. [Online]. Available: https://en.wikipedia.org/wiki/Flow_coefficient#cite_note-3.
- [23] Word press, "<https://mgdic.files.wordpress.com>," 2015. [Online]. Available: https://mgdic.files.wordpress.com/2016/12/unit_3_flow_measurement_techniques.pdf.
- [24] Wikipedia, "Vortex shedding".
- [25] F.LaurantzonR.ÖrlüA.SegaliniN.TillmarkP.H.Alfredsson, "Experimental analysis of turbocharger interaction with a pulsatile flow through time-resolved flow measurements upstream and downstream of the turbine," *10th International Conference on Turbochargers and Turbocharging*, pp. 405-415, 2012.
- [26] Badget meter co., "<https://www.badgermeter.com>," Badget meter, 2018. [Online]. Available: <https://www.badgermeter.com/brands/vortex/>.
- [27] Omega, "<https://www.omega.com>," Omega, 2016. [Online]. Available: <https://www.omega.com/prodinfo/vortex-flow-meter.html#faq>.
- [28] M. E. Perrin, "An Application of Vortex Shedding Flowmeters," *American Water Works Association*, vol. 69, pp. 162-165, 1977.
- [29] Azo materials, "<https://www.azom.com>," AzoM, 14 March 2017. [Online]. Available: <https://www.azom.com/article.aspx?ArticleID=13680>.
- [30] Wikipedia, "Thermal mass flow meter," Wikipedia, 2017.
- [31] T&M world, "<http://www.test-and-measurement-world.com>," T&M world, [Online]. Available: <http://www.test-and-measurement-world.com/Terminology/Advantages-and-Disadvantages-of-Thermal-Mass-Flowmeter.html>.
- [32] Thermal instrument co., "<https://www.thermalinstrument.com>," Thermal instrument co., [Online]. Available: <https://www.thermalinstrument.com/mass-flow-meters/>.
- [33] Universal flow monitors, "<http://www.flowmeters.com>," UFM, [Online]. Available: <http://www.flowmeters.com/coriolis-mass-technology>.
- [34] Brankhorst, "<https://www.bronkhorst.com>," Brankhorst, [Online]. Available: <https://www.bronkhorst.com/service-support/technologies/coriolis-mass-flow-measuring-principle/>.
- [35] Metern, "<http://www.metern.net>," Metern, [Online]. Available: <http://www.metern.net/blog-metern-in-the-flow/coriolis-mass-flow-meter-advantages-and-disadvantages-8.html>.

- [36] Omega engineering Inc., "<https://www.omega.co.uk/literature/transactions/volume3/strain2.html>," OMEGA, [Online]. Available: <https://www.omega.co.uk/literature/transactions/volume3/strain2.html>.
- [37] Induflex A/S, "http://www.pmma.dk/Acryl_anvendelse.aspx?Lang=en-GB," Induflex A/S, [Online]. Available: http://www.pmma.dk/Acryl_anvendelse.aspx?Lang=en-GB.
- [38] David Proctor, "Cut my plastic," 18 August 2018. [Online]. Available: <https://www.cutmyplastic.co.uk/blog/pros-cons-perspex-sheets/>.
- [39] Blue Robotics, "<https://www.bluerobotics.com>," Blue Robotics, [Online]. Available: <https://www.bluerobotics.com/store/electronics/bar30-sensor-r1/>. [Accessed 2017].
- [40] Nathan Salowitz, Ehsan Sanatizadeh, Armin Yazdi, "Performance monitoring of reverse osmosis water filtration systems," Milwaukee, 2018.
- [41] Blue Robotics, "<https://www.bluerobotics.com>," Blue Robotics, 2018. [Online]. Available: <https://www.bluerobotics.com/store/electronics/bar30-sensor-r1/>.
- [42] Blue Robotics, "<https://www.bluerobotics.com>," Blue Robotics Inc., 2018. [Online]. Available: <https://www.bluerobotics.com/store/sensors-sonars-cameras/sensors/level-converter-r1/>.
- [43] National instruments, "<http://www.ni.com>," National instruments, [Online]. Available: <http://www.ni.com/data-acquisition/what-is/>.
- [44] Symetry electronics, "<https://www.semiconductorstore.com>," TTI Semiconductor group, 28 6 2014. [Online]. Available: <https://www.semiconductorstore.com/blog/2014/Arduino-Development-Kits-Advantages-and-Features/811/>.
- [45] Sparkfun Electronics, "<https://learn.sparkfun.com>," Sparkfun Electronics, [Online]. Available: <https://learn.sparkfun.com/tutorials/what-is-an-arduino/all>.
- [46] Sparkfun Electronics, "<https://learn.sparkfun.com>," Sparkfun Electronics, [Online]. Available: <https://learn.sparkfun.com/tutorials/what-is-an-arduino/all>.
- [47] E funda(Engineering fundamentals), "Strain gauge installation," E funda, 1999. [Online]. Available: http://www.efunda.com/designstandards/sensors/strain_gages/strain_gage_installation.cfm.
- [48] E. S. P. W. M. D. M. Suresh Sivananthan, Mercer's Textbook of Orthopaedics and Trauma Tenth edition, CRC Press, 2012.
- [49] Wikibooks, "Strength of Materials/Loading of Beams," 9 6 2015. [Online]. Available: https://en.wikibooks.org/wiki/Strength_of_Materials/Loading_of_Beams.
- [50] A. S. Vasudeva, A Textbook of Engineering Physics (Orissa), S. Chand Publishing, 2008.
- [51] J. Case, The Strength of Materials, Keybam: Hodder & Stoughton Educational, 1971.
- [52] Paidoussis, Michael Paidoussis Michael, Fluid- Structure ineractions, 2003.

Appendices

Appendix A: Testing plan for classic target meter

Classic Target Meter	Thickness	Beam length	Beam width	Plate number	Plate's diameter	Target plate's diameter	circular edge dimension	trend	SD
1	0.125	0.3	0.3	1	2.36	1.4	0.18		0.011018
2	0.125	0.3	0.4	2	2.36	1.4	0.18	b	0.008316
3	0.125	0.3	0.5	3	2.36	1.4	0.18	b	0.006628
4	0.125	0.4	0.3	4	2.36	1.2	0.18	nb	0.003105
5	0.125	0.4	0.4	5	2.36	1.2	0.18	g	0.00229
6	0.125	0.4	0.5	6	2.36	1.2	0.18		0.00198
7	0.125	0.5	0.3	7	2.36	1	0.18	b	0.00044
8	0.125	0.5	0.4	8	2.36	1	0.18	b	0.00042
9	0.125	0.5	0.5	9	2.36	1	0.18	b	0.00041
10	0.1875	0.3	0.3	1	2.36	1.4	0.18	nb	0.004693
11	0.1875	0.3	0.4	2	2.36	1.4	0.18	nb	0.003476
12	0.1875	0.3	0.5	3	2.36	1.4	0.18	b	0.002777
13	0.1875	0.4	0.3	4	2.36	1.2	0.18		0.001119
14	0.1875	0.4	0.4	5	2.36	1.2	0.18	nb	0.000725
15	0.1875	0.4	0.5	6	2.36	1.2	0.18		0.000722
16	0.1875	0.5	0.3	7	2.36	1	0.18	b	0.000613
17	0.1875	0.5	0.4	8	2.36	1	0.18	b	0.000367
18	0.1875	0.5	0.5	9	2.36	1	0.18	b	0.000377
19	0.25	0.3	0.3	1	2.36	1.4	0.18	b	0.001458
20	0.25	0.3	0.4	2	2.36	1.4	0.18	nb	0.001113
21	0.25	0.3	0.5	3	2.36	1.4	0.18	b	0.000828
22	0.25	0.4	0.3	4	2.36	1.2	0.18	nb	0.000635
23	0.25	0.4	0.4	5	2.36	1.2	0.18		0.000344
24	0.25	0.4	0.5	6	2.36	1.2	0.18	b	0.001251
25	0.25	0.5	0.3	7	2.36	1	0.18	b	0.000409
26	0.25	0.5	0.4	8	2.36	1	0.18	b	0.000635
27	0.25	0.5	0.5	9	2.36	1	0.18	b	0.000297

Appendix B: Testing plan for Hybrid target meter

Hybrid Target Meter	Number of holes	Size of holes	Thickness	Beam length	Beam width	Plate number	Plate's diameter	Trend	SD
1	4	0.2	0.125	0.5	0.5	1	2.36	g	0.000641
2	4	0.2	0.125	0.5	1	2	2.36	b	0.000426
3	4	0.2	0.125	0.75	0.5	3	2.36		0.000489
4	4	0.2	0.125	0.75	1	4	2.36	g	0.000546
5	4	0.2	0.125	1	0.5	5	2.36		0.001259
6	4	0.2	0.125	1	1	6	2.36		0.000997
7	4	0.2	0.1875	0.5	0.5	1	2.36	b	0.000524
8	4	0.2	0.1875	0.5	1	2	2.36	nb	0.000515
9	4	0.2	0.1875	0.75	0.5	3	2.36		0.000328
10	4	0.2	0.1875	0.75	1	4	2.36	b	0.000485
11	4	0.2	0.1875	1	0.5	5	2.36	b	0.000859
12	4	0.2	0.1875	1	1	6	2.36	b	0.000728
13	4	0.2	0.25	0.5	0.5	1	2.36		0.000466
14	4	0.2	0.25	0.5	1	2	2.36		0.000673
15	4	0.2	0.25	0.75	0.5	3	2.36		0.000546
16	4	0.2	0.25	0.75	1	4	2.36		0.000377
17	4	0.2	0.25	1	0.5	5	2.36	nb	0.000455
18	4	0.2	0.25	1	1	6	2.36	b	0.000304

Appendix C: Testing plan for Hybrid cantilevered meter

Hybrid Cantilevered	number of holes	size of holes	thickness	beam length	beam width	Plate number	Hole's diameter	Trend	SD
1	6	0.2	0.125	0.3	0.3	1	0.2	b	0.03899
2	6	0.2	0.125	0.3	0.4	2	0.2	g	0.028464
3	6	0.2	0.125	0.3	0.5	3	0.2		0.022778
4	6	0.2	0.125	0.5	0.3	4	0.2	g	0.039825
5	6	0.2	0.125	0.5	0.4	5	0.2		0.029518
6	6	0.2	0.125	0.5	0.5	6	0.2	g	0.023563
7	6	0.2	0.1875	0.3	0.3	1	0.2	g	0.008341
8	6	0.2	0.1875	0.3	0.4	2	0.2	g	0.012625
9	6	0.2	0.1875	0.3	0.5	3	0.2	g	0.010393
10	6	0.2	0.1875	0.5	0.3	4	0.2		0.016859
11	6	0.2	0.1875	0.5	0.4	5	0.2	g	0.011478
12	6	0.2	0.1875	0.5	0.5	6	0.2	nb	0.010479
13	6	0.2	0.25	0.3	0.3	1	0.2		0.010497
14	6	0.2	0.25	0.3	0.4	2	0.2	g	0.007377
15	6	0.2	0.25	0.3	0.5	3	0.2	g	0.002785
16	6	0.2	0.25	0.5	0.3	4	0.2	g	0.004613
17	6	0.2	0.25	0.5	0.4	5	0.2	g	0.007901
18	6	0.2	0.25	0.5	0.5	6	0.2	g	0.002802