

HUMAN FACTORS

SUMMARY

Human factors is the study of human dimensions and attributes related to the design of objects which people use, primarily equipment. Included subjects of this section are chalkboards, cabinets, sinks, toilets, and drinking fountains. The performance of these items 'in use' is primarily measured by comparison with the standard dimensions of their users.

In addition to dimensional criteria the performance of chalkboards is also measured for performance related to glare affecting visibility. The provision of adequate display area from quantitative and qualitative performance standpoints is a part of the direct human factors 'interface' of person and environment and is also part of the component scale of activity support. Existing standards and actual use are contrasted to the design of display in all four schools.

ANTHROPOMETRICS

Performance Required: Provide components which are dimensionally compatible with the users of the schools.

Method: Comparison of dimensions of certain critical components of the school with existing standards. Sources include Time Saver Standards, Complete Guide to Planning New Schools, N. Englehardt, The Measure of Man, 2nd Edition, H. Dreyfuss.

Analysis:

ANTHROPOMETRICS

	<u>STANDARDS</u>		<u>P</u>		<u>R</u>		<u>S</u>		<u>M</u>	
	<u>GRADES</u>		1-3	4-6	1-3	4-6	1-3	4-6	1-3	4-6
	1-3	4-6								
CHALKBOARD(bottom)	25"	29"	18"	24"	30"	30"	33"	33"	28"	32"
CAFETERIA COUNTER	31"	36"				35"	31"	36"		36"
DRINKING FOUNTAIN	27"	32"	26"	32"	28"	28"	30"	32"	28"	34"
SINK	26"	29"	24"	30"	26"	26"	28"	30"	26"	32"
WATER CLOSET(seat)	11"	14"		16"		16"		16"		16"

Findings: A comparison between existing standards and the actual dimensions indicates some discrepancies of which a few are critical. At the Richards and Smith School blackboard height is a real problem in the lower grades. A few teachers mentioned that 'platforms' were necessary to reach the chalkboard. Other items, though not standard, are within an acceptable range.

CHALKBOARD GLARE

Performance Required: Provide chalkboard with adequate contrast to read chalk writing.

Method: Comparison of performance with existing reflectance standards. Use of reflected and incident lighting measures. See Field Test Manual - Section G.

Analysis: Criteria: 'Black' chalkboards reflectance levels should not exceed 20%; it shall be free from visible 'ghost lines'; source: SCSD Performance Specifications.

CHALKBOARD GLARE	RECOMMENDED STANDARDS	P	R		S
			I*	O*	
PERPENDICULAR POSITION	20% Max. Refl.	7%	10%	7%	10%
WORST SEAT POSITION	20% Max. Refl.	43%	10%	29%	45%

I* no window near board
O* window perp. to board

A combination of chalkboard placement and window size and location produce veiling reflections (inability to read writing on board) when window shades are not drawn at the Parkside and Smith School. Very serious glare (approx. 40%) is present. When shades are drawn performance is satisfactory. At the Richards School performance is generally satisfactory.

'BUILDINGS IN USE' STUDY

BLACKBOARD DIMENSIONS

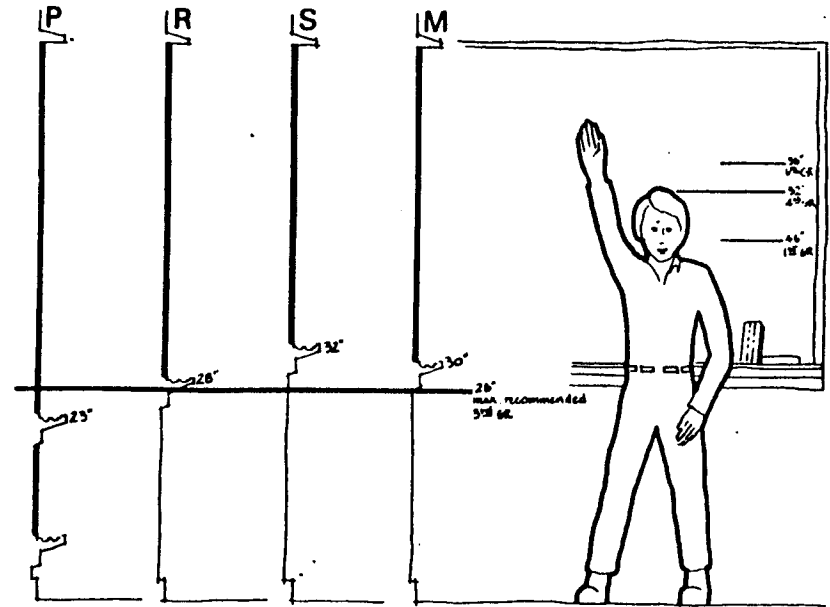

BLACKBOARD GLARE

DISPLAY TAPED TO THE BLACKBOARD
OFTEN OCCURS HERE, IN THE AREA OF
WORST REFLECTIONS

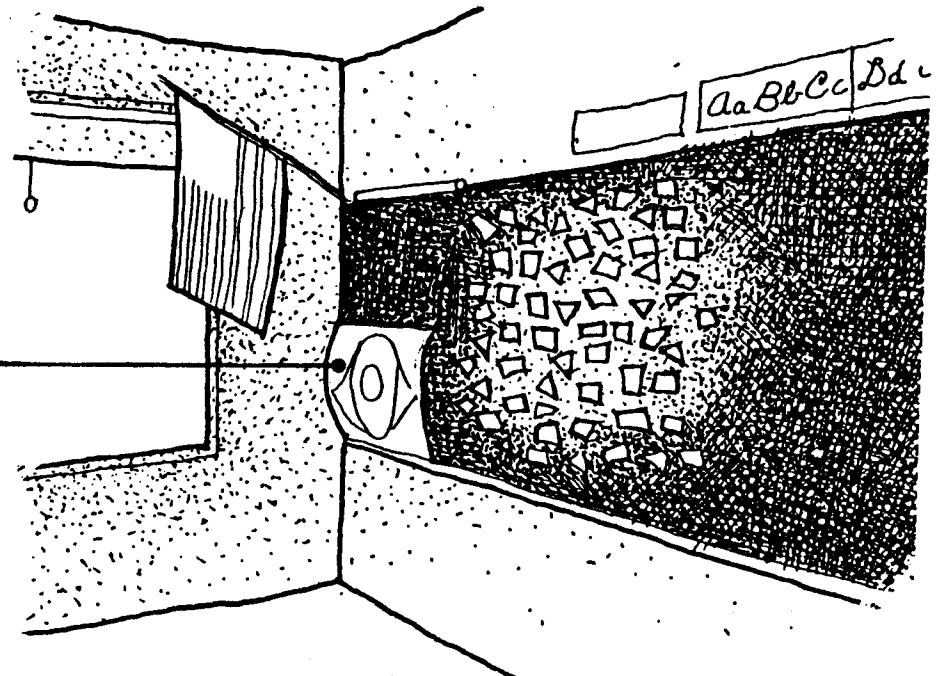

BLACKBOARD GLARE : SMITH

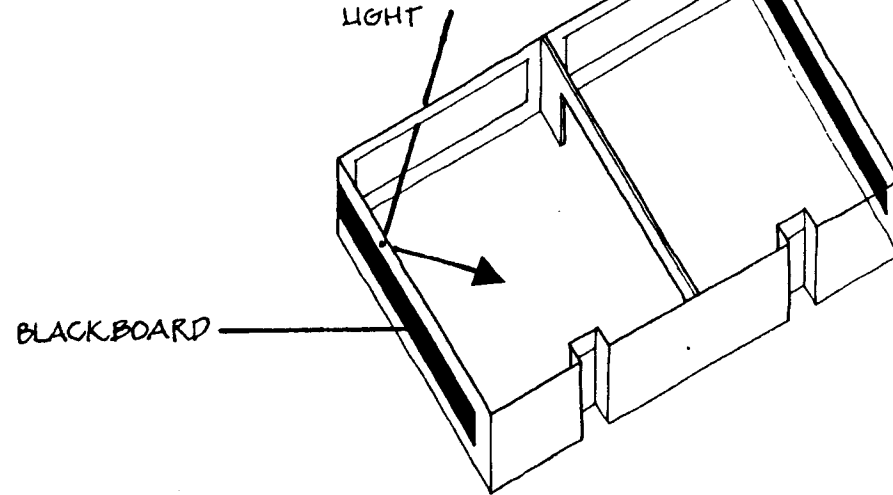

BLACKBOARD GLARE : RICHARDS

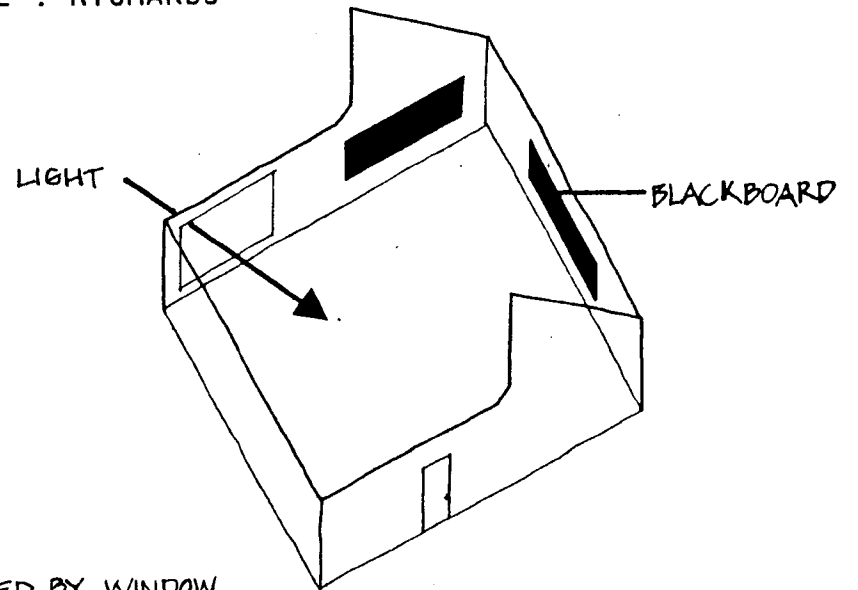

GLARE IS MINIMIZED BY WINDOW LOCATION IN REAR OF CLASSROOM

DISPLAY

Performance required: Provide adequate area and attributes for displaying materials especially drawings, visuals, etc., in the school.

Method: Existing standards were found. A comparison of existing standards and actual quantity of display area in classrooms was made. Photographic sampling was used to measure the amount of display actually used. Ad hoc solutions to display were documented.

Analysis:

DISPLAY AREA

	RECOMMENDED STANDARDS	P	R	S	M
QUANTITY (linear feet)	30	20	20	30**	30
QUANTITY (square feet)	75*	80	80	60**	120

*this published standard was found to be low

**largely unusable due to placement

The quantity of display ranges from a less than usable 60 sq. ft. at Smith School to 120 sq. ft. at Mt. Healthy.

The findings have as their basis the assumption that maximizing opportunity for display usage within reasonable boundaries is called for. Many teachers will utilize these opportunities fully, some less and a few not at all - the latter emphasizing alternative media or methods.

Our observations found 'overflow' display in most classrooms except Mt. Healthy where display space was adequate. At Smith the overflow often occurred on the blackboard next to the window where glare is worst, this adaptation resolved the use of this problem area; on the window shades - they are often closed; in the hallway, although it is difficult to hang pictures on raw concrete; and in some case from the light-fixtures using paper clips and string. The displayed objects in this and the other schools were varied-primarily students drawings, educational charts and visuals, teacher cut outs, etc.

At the Parkside and Richards Schools the existing display area was well used with some overflow onto the walls. Richards School block walls are easily used for display compared to the brick back wall at Parkside where in some uses teachers have strung a 'clothesline' to hang pictures, cut outs, and constructions. At Mount Healthy display is rampant and most surfaces in classrooms and corridors are used.

Findings: We believe that approximately 25 linear feet (100 sq. ft.) of display space would be sufficient for most teachers. Most surfaces should be tackable and some provision should be made for ceiling attachment. Provision should also be made for display in corridors. Based on the above the Smith School needs quite a bit more useful display area and the Parkside and Richards Schools need only another increment, say 4-6 linear feet, of display. At Mount Healthy the display area is sufficient.