

LIGHTING

INTRODUCTION

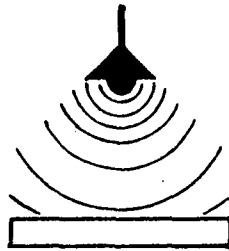

Artificial and natural lighting provide the visual environment necessary for typical classroom activities. The performance of this visual environment is determined by a number of factors acting together: the quantity of light, the type of task, room brightness ratios, direct and reflected glare, and contrast rendition of the task surface. The quantity of illumination, which is the most common measure, alone is not a valid measure of lighting quality. In fact, improperly designed, a higher quantity of light can have a detrimental, rather than a beneficial, effect on occupants.

Unlike other technical factors included in our study which produce easily-recognizable and sometimes severe problems, improper lighting design produces eye strain, fatigue and discomfort which would be easily noticeable and attributable only under the most extreme conditions. The more subtle effects are difficult to pinpoint, but nonetheless affect the user.

Our criteria for good lighting design are taken from sources which include all the above mentioned factors and which should eliminate adverse physiological effects. Determining the performance of each of these characteristics and comparing these with recommended standards should produce a good indication of the quality, as well as the quantity, of lighting in the existing classrooms environments.

METHOD OF EXAMINATION

Measurements of the quantity of light (in classroom areas, only) were made with a General Electric Type 213 Light (foot-candle) Meter. Other measurements requiring luminance (foot-lamberts) readings were performed with Minolta and Honeywell (1°) spot meters. Measurements were made during different weather conditions and with the window shades in different positions. For a detailed description of the testing procedures used, refer to the Field Tests Manual, 'Buildings In Use' Study, December, 1974.

SUMMARY OF PERFORMANCE

	P	R	S	M
LIGHTING				
Illumination	○	⊙	○	⊙
Room Contrast Ratios	●	⊙	●	○
Glare	●	⊙	●	○
Task/Immediate Surround Contrast Ratios	○	○	○	○
Darkened Room	●	○	○	○

SUMMARY OF FINDINGS

The visual environments of the classrooms in all schools were entirely satisfactory in terms of the quantity of light present. However, in those schools whose classrooms had large window areas, such as Parkside and Smith, performance in the areas of room contrast ratios and direct glare was not acceptable, generally functioning at below the 75% level. The Mount Healthy School, depending heavily on artificial illumination with windows used primarily for visual relief and high lighting, had the most satisfactory lighting environment with performance generally at the 95% level. The Richards School, which had smaller windows in each classroom and used large skylights, was also acceptable, functioning at the 85% level.

DETAILS OF FINDINGS

LIGHTING/ILLUMINATION (FOOTCANDLES)

Results: Performance levels with regard to the quantity of illumination were satisfactory at all schools examined. Some exceptional conditions exist at the Mount Healthy School which make technical performance evaluation difficult. Richards had lower illumination than recommended standards (85% level).

Probable cause: Existing criteria in the technical literature are based on traditional classrooms, and Mount Healthy is a radical departure from that model. At the Richards School many bulbs are not producing maximum light output.

Discussion: Illumination refers to the quantity of light incident on a work surface, and visual acuity generally increases with increased illumination. It is important to note that United States requirements in this regard are very high, in that they are based on performing difficult reading tasks with a high degree of acuity, and that lower standards, we believe, are quite acceptable. Mount Healthy has locations in 2 classroom areas which fall below the United States standard but which we believe are acceptable due to (a) the aforementioned 'luxurious' existing standards; (b) the tasks in the schools not approaching the criticalness of the task by which the standard was set; and (c) the openness of the school providing immediately adjacent areas where high level illumination exists. At the Richards School bulb replacement is necessary.

LIGHTING: ROOM CONTRAST RATIOS

Results: Performance levels at the Mount Healthy and Richards Schools were generally satisfactory, functioning at the 85% level. Parkside and Smith typically have poorer performance (75% or below) in this area.

Probable cause: Extensive window areas within the user's cone of vision result in high contrast ratios.

Discussion: The ratios of reflected light from larger surfaces

in a room determine the room contrast ratio. Adjacent surfaces with high contrast will produce eye muscle tension and visual fatigue. With the window shades open, room contrast ratios exceed those generally recommended. Only when the shades are fully drawn does the contrast ratio become acceptable (within 1:10 ratio). When the teacher closes the shade it is probably to eliminate direct glare, especially sky glare, and to reduce the size of the glare source.

The large windows at the Smith and Parkside Schools are the source of the very high room contrast ratios found. The Richards School windows, which are smaller (12 feet long) and in most classrooms are in the rear of the room, are most satisfactory, performing at the 95% level. They are large enough to create a 'space' for projects and activities while their location in the rear of the room and diminished size provide an adequate room contrast ratio.

LIGHTING: GLARE

Results: Performance levels at Parkside and Smith, are generally below the 75% level. Performance levels at Richards and Mount Healthy, 85% and 95% respectively, were satisfactory.

Probable cause: Intensity of the illumination created by the classroom windows.

Discussion: Room contrast ratios notwithstanding, the absolute amount of glare may be enough to provide the detrimental physiological effects described previously. An analogous, though exaggerated, situation, disability glare, occurs when looking directly into the high beam headlights of on-coming automobiles. In a classroom situation, discomfort glare results in an elevated blinking rate, muscle tension and lessened visual efficiency. Classrooms with large southern windows at the Parkside and Smith Schools receive direct glare in excess of recommended levels. Large windows at Smith and Parkside produce from 300-2600 foot-lamberts with shades open when the upper limit is reasonably

400 foot-lamberts. Shades are often drawn only halfway to screen out sky glare which is in the 1000-3000 foot-lamberts range. Glare from lighting fixtures was not a problem in any of the schools due to the use of adequate diffusers and shielding of the bulbs. At Mt. Healthy, though, no diffuser is used on fluorescent luminaires, they are above the normal cone of vision.

LIGHTING: TASK/IMMEDIATE SURROUND CONTRAST RATIOS

Results: Satisfactory in all schools.

Probable cause: Not applicable

Discussion: Due to the light colors chosen for desk tops and flooring materials.

LIGHTING: DARKENED ROOM

Results: Satisfactory at Smith, and Richards Schools.

Unsatisfactory (below 75% performance) at Parkside School.

Probable cause: Shades are semi-opaque

Discussion: Measurements in Parkside classrooms with south orientations produced readings over 300 foot-lamberts on the shades in bright sunlight which is detrimental to audio visual as insufficient contrast is produced in the image. Six footlamberts were read on the screen and from 4-11 footcandles in the classroom.

The Richards and Smith Schools produced 0 footcandles (almost complete darkness) which is satisfactory.

G.1 ILLUMINATION/ARTIFICIAL LIGHTING/CLASSROOMS

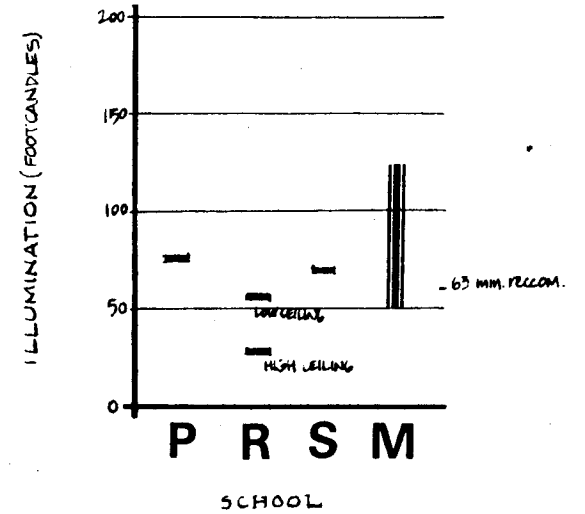

G.2 ILLUMINATION/ARTIFICIAL & NATURAL LIGHTING/CLASSROOMS

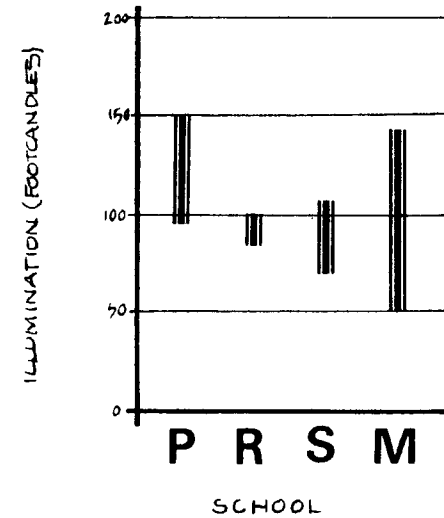

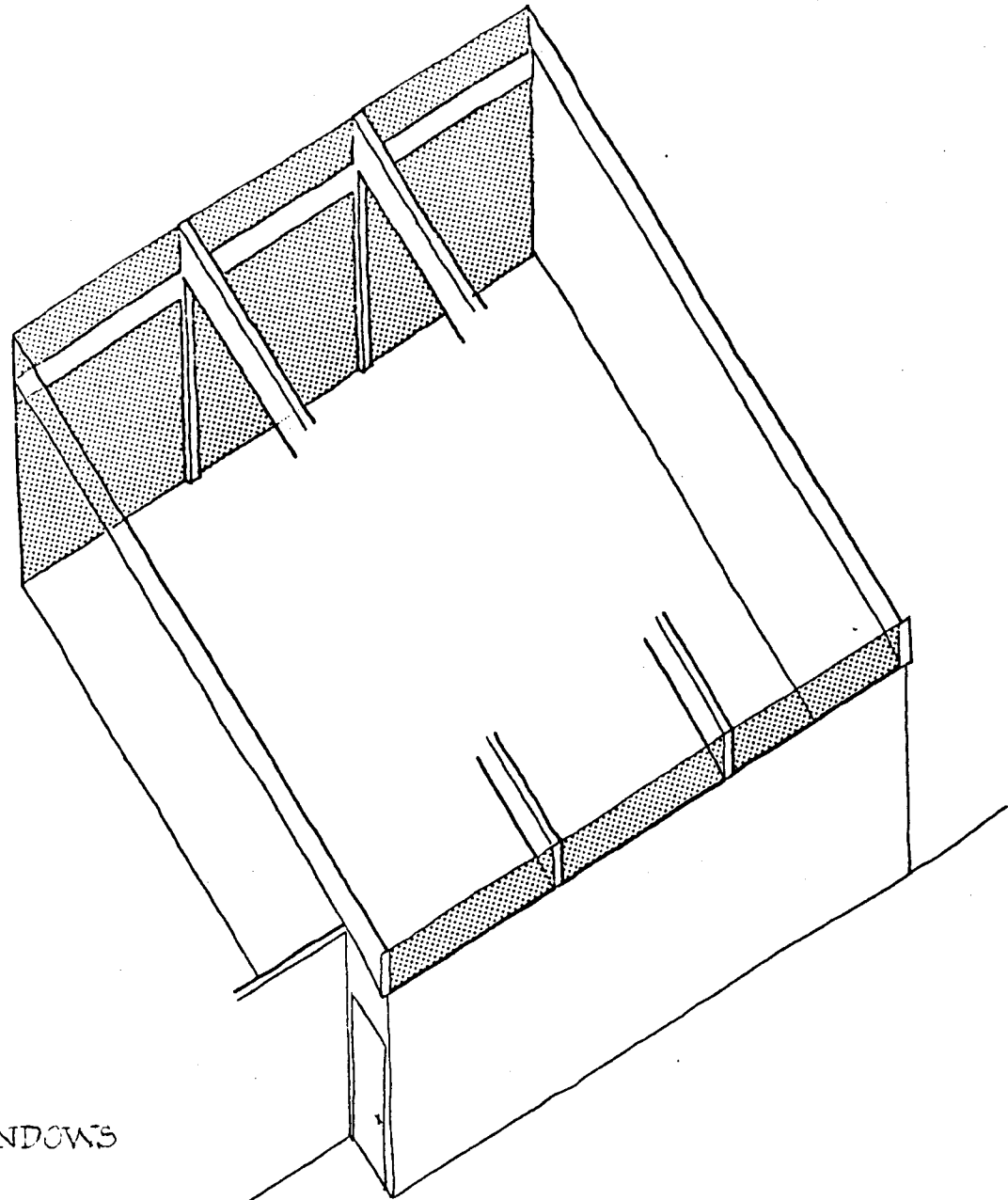

fig. G.3
PARKSIDE SCHOOL/CLASSROOM/WINDOWS

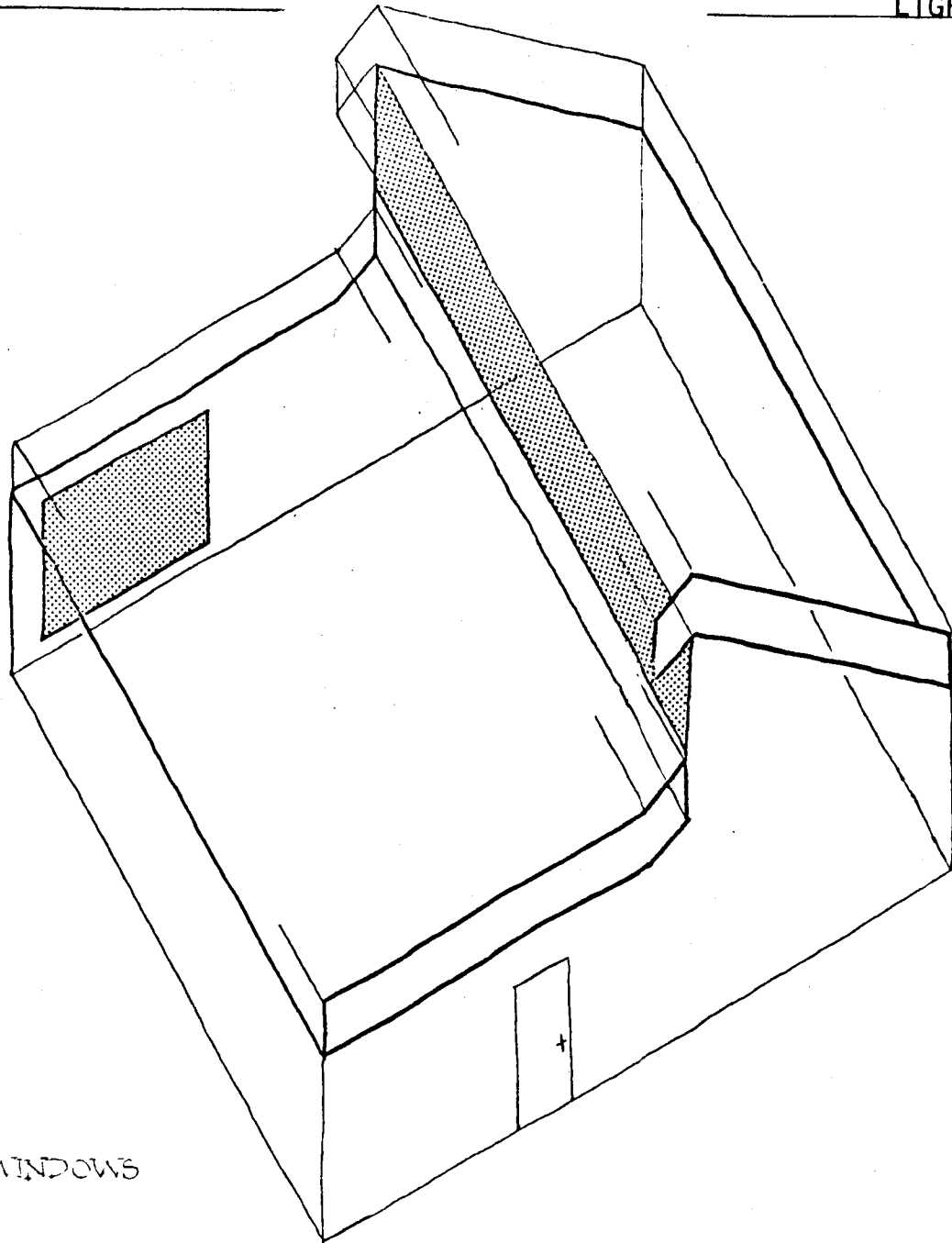

fig. G.4
RICHARDS SCHOOL/CLASSROOM/WINDOWS

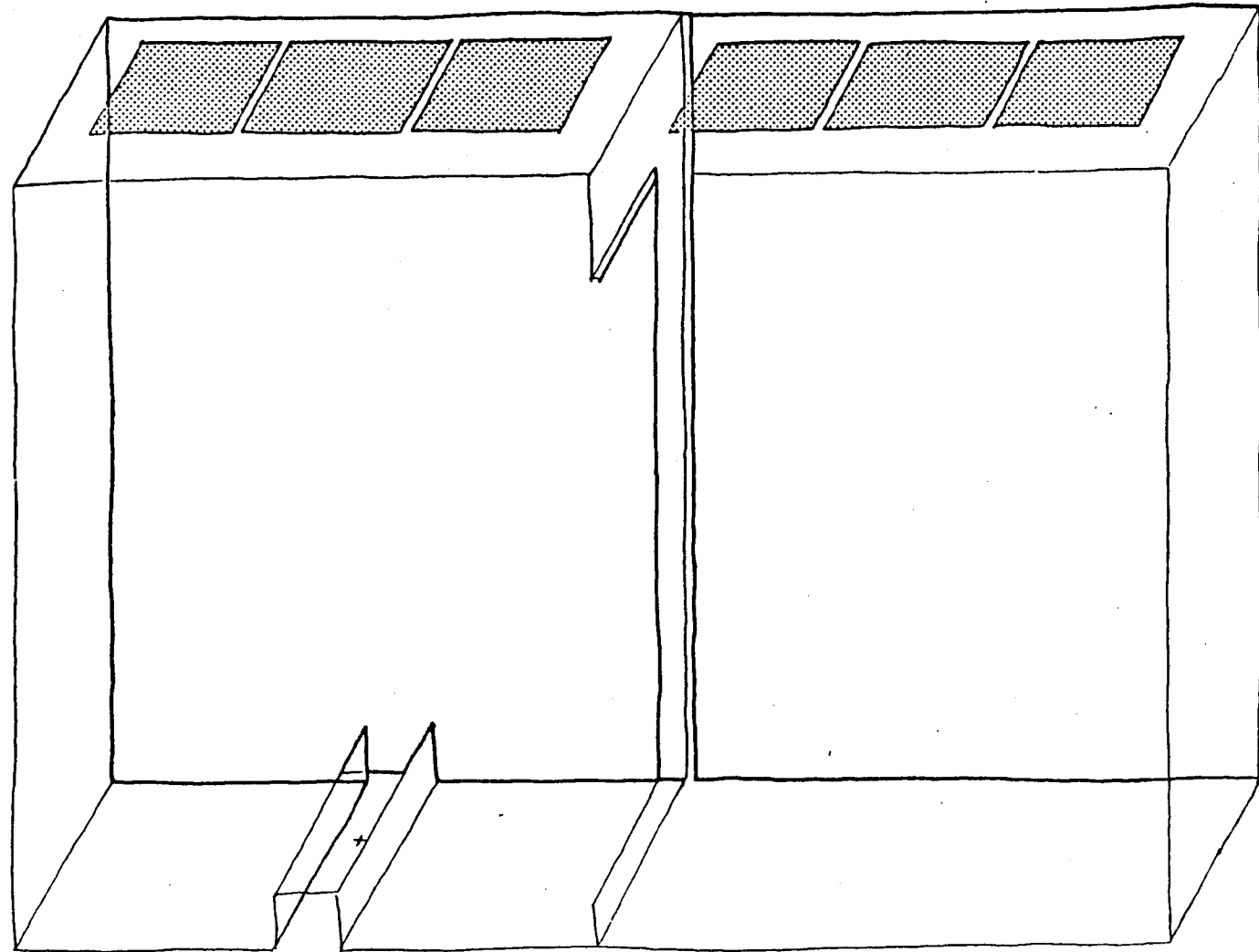

fig. G.5
SMITH SCHOOL/DOUBLE CLASSROOM/WINDOWS

BUILDINGS IN USE' STUDY

LIGHTING

LUMINANCE/CLASSROOMS
 figures are in footlamberts

G.6 PARKSIDE SOUTH - BRIGHT SUN

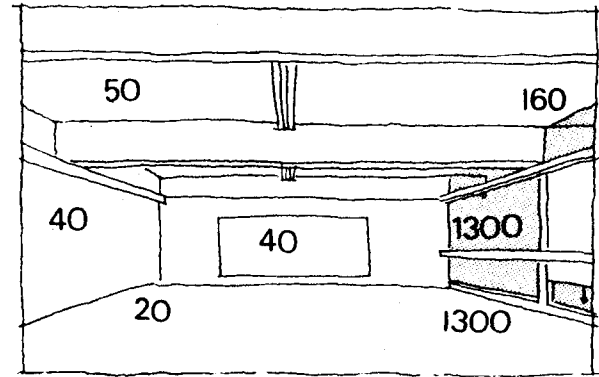

G.7 RICHARDS SOUTH - CLOUDY

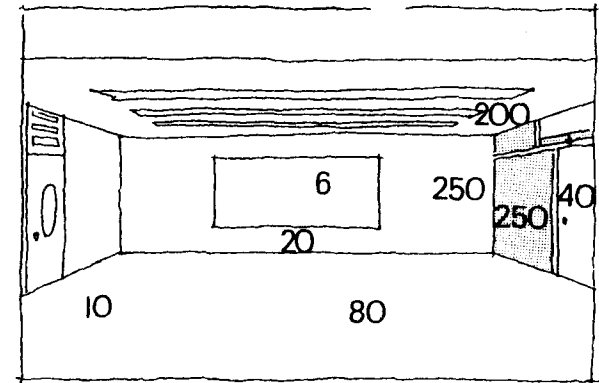

G.8 SMITH SOUTH - CLOUDY BRIGHT

